

Gulf and Caribbean Research

Volume 4 | Issue 1

January 1972

A Study of Nektonic and Benthic Faunas of the Shallow Gulf of Mexico Off the State of Mississippi As Related to Some Physical, Chemical, and Geological Factors

James S. Franks

Gulf Coast Research Laboratory

J.Y. Christmas

Gulf Coast Research Laboratory

Walter L. Siler

Gulf Coast Research Laboratory

Ralph Combs

Gulf Coast Research Laboratory

See next page for additional authors

Follow this and additional works at: <https://aquila.usm.edu/gcr>



Part of the [Marine Biology Commons](#)

Recommended Citation

Franks, J. S., J. Christmas, W. L. Siler, R. Combs, R. Waller and C. Burns. 1972. A Study of Nektonic and Benthic Faunas of the Shallow Gulf of Mexico Off the State of Mississippi As Related to Some Physical, Chemical, and Geological Factors. *Gulf Research Reports* 4 (1): 1-148.

Retrieved from <https://aquila.usm.edu/gcr/vol4/iss1/1>

DOI: <https://doi.org/10.18785/grr.0401.01>

This Article is brought to you for free and open access by The Aquila Digital Community. It has been accepted for inclusion in *Gulf and Caribbean Research* by an authorized editor of The Aquila Digital Community. For more information, please contact aquilastaff@usm.edu.

A Study of Nektonic and Benthic Faunas of the Shallow Gulf of Mexico Off the State of Mississippi As Related to Some Physical, Chemical, and Geological Factors

Authors

James S. Franks, *Gulf Coast Research Laboratory*, J.Y. Christmas, *Gulf Coast Research Laboratory*, Walter L. Siler, *Gulf Coast Research Laboratory*, Ralph Combs, *Gulf Coast Research Laboratory*, Richard Waller, *Gulf Coast Research Laboratory*, and Charles Burns, *Gulf Coast Research Laboratory*

**A STUDY OF NEKTONIC AND BENTHIC FAUNAS
OF THE SHALLOW GULF OF MEXICO
OFF THE STATE OF MISSISSIPPI
AS RELATED TO SOME PHYSICAL, CHEMICAL
AND GEOLOGICAL FACTORS**

by

James S. Franks, J.Y. Christmas, Walter L. Siler,
Ralph Combs, Richard Waller and Charles Burns

GULF COAST RESEARCH LABORATORY
Ocean Springs, Mississippi
1972

This study was conducted in cooperation with the Department of
Commerce, National Marine Fisheries Service, under Public Law
88-309, Project 2-42-R.

Table of Contents

	Page
I. List of Tables and Figures	iii
II. Abstract	1
III. Introduction	2
IV. Station Location and Identification	5
V. Bathymetry	8
VI. Materials and Methods	8
VII. Hydrology	10
Temperature	10
Salinity	13
Chemical Determinations	15
Transparency	15
VIII. Sedimentology	17
Background	17
Technique	18
Findings	18
Sediment Composition	20
Size	20
IX. Plankton Sampling	24
Common Plankters	27
Phytoplankton	27
Zooplankton	27
X. Dredge Sampling	37
Species Account	38
XI. Nekton Sampling	40
XII. Trawl Sampling	42
Laboratory Work on Samples	43
Systematic Account — Invertebrates	44
Systematic Account — Fishes	66
XIII. Relative Abundance	129
Seasonal Bathymetric Distribution	132
Length-Frequency Distribution	134
XIV. Estuarine Relationships	134
XV. Summary	136
XVI. Literature Cited	139
XVII. Index	144

List of Tables and Figures

TABLES	Page
1. Number of Monthly Hauls	7
2. Monthly Mean Temperature and Salinity	11
3. Minimum, Maximum, Range and Mean of Monthly Average Temperature	14
4. Minimum, Maximum, Range and Mean of Monthly Average Salinity	14
5. Monthly Mean Nitrate, Nitrite, Total Phosphate and Ortho-phosphate	16
6. Monthly Transparency Observations (May 1968 - May 1969)	19
7. Sediment Properties of Offshore Stations	21
8. Number of Offshore Plankton Samples Examined	26
9. Settled Volumes, Salinity, Temperature and Relative Abundance of Common Plankters	28
10. Total Dredge Catch from Six Offshore Stations	39
11. Surface and Benthic Nekton Hauls	41
12. Species Most Commonly Encountered in Nekton Hauls	43
13. Distribution of <i>Lolliguncula brevis</i> by Bottom Salinity and Temperature Intervals	48
14. Distribution of <i>Penaeus aztecus</i> by Bottom Salinity and Temperature Intervals	52
15. Distribution of <i>Penaeus fluviatilis</i> by Bottom Salinity and Temperature Intervals	55
16. Distribution of <i>Callinectes sapidus</i> by Bottom Salinity and Temperature Intervals	60
17. Distribution of <i>Callinectes similis</i> by Bottom Salinity and Temperature Intervals	62
18. Contribution of Each Family to Total Catch of Fishes	67
19. Percentage Distribution of Commercially Important Families	67
20. Distribution of <i>Anchoa hepsetus</i> by Bottom Salinity and Temperature Intervals	75
21. Distribution of <i>Galeichthys felis</i> by Bottom Salinity and Temperature Intervals	80
22. Distribution of <i>Centropristes ocyurus</i> by Bottom Salinity and Temperature Intervals	85
23. Distribution of <i>Cynoscion arenarius</i> by Bottom Salinity and Temperature Intervals	92
24. Distribution of <i>Leiostomus xanthurus</i> by Bottom Salinity and Temperature Intervals	95
25. Distribution of <i>Micropogon undulatus</i> by Bottom Salinity and Temperature Intervals	98
26. Distribution of <i>Lagodon rhomboides</i> by Bottom Salinity and Temperature Intervals	101
27. Distribution of <i>Stenotomus caprinus</i> by Bottom Salinity and Temperature Intervals	104

28.	Distribution of <i>Peprilus burti</i> Fowler by Bottom Salinity and Temperature Intervals114
29.	Distribution of <i>Cyclopsetta chittendeni</i> by Bottom Salinity and Temperature Intervals118
30.	Distribution of <i>Syacium gunteri</i> by Bottom Salinity and Temperature Intervals123
31.	Relative Numbers of the Most Abundant Fishes130
32.	Relative Numbers of the 12 Most Abundant Invertebrate Species130

FIGURES

1.	The "Big House"	4
2.	Location of Work	6
3.	Bottom Profile	9
4.	Nitrate Concentrations (May 1968 through May 1969)	17
5.	Total Phosphate Concentrations (May 1968 through May 1969)	18
6.	Nomenclature for Bottom Sediments Based on Grain Size	22
7.	Average Grain Size of Bottoms of Offshore Stations	23
8.	Type of Closing Plankton Net Used in Sampling	25
9.	Relative Abundance of Number Caught and Weight of Twenty-one Species of Trawl Caught Fishes (1967-1969)131
10.	Offshore Seasonal Bathymetric Distribution of <i>Micropogon undulatus</i> and <i>Stenotomus caprinus</i>132
11.	Offshore Seasonal Bathymetric Distribution of <i>Cynoscion arenarius</i> , <i>Peprilus burti</i> , <i>Leiostomus xanthurus</i> and <i>Penaeus aztecus</i>133

Acknowledgements

Mr. C. E. Dawson originally served as principal investigator for this project. We sincerely acknowledge his contributions to this study.

Mr. Felix Jackson worked as project staff member throughout the program.

We hereby acknowledge their contribution and the work of many others who, from time to time, gave assistance.

Abstract

A seasonal study of the nektonic and benthic faunas of the shallow Gulf of Mexico off Mississippi was conducted from January 1967 through May 1969. It was planned to sample monthly six fixed offshore stations at depths ranging from 5 to 50 fathoms in the open Gulf. In general this was carried out fairly well, as shown by Table 1.

Water samples were taken from surface, midwater, and bottom levels each time a station was occupied, and temperatures and salinities were recorded for each of these. Samples were tested for the presence of nitrates, nitrites, ortho-phosphates and total phosphates. Secchi disc extinction points were recorded. Grab samples were taken for the determination of bottom composition.

Plankton samples were taken from surface, midwater and bottom levels. Copepods, brachyuran zoea and megalops, stomatopod larvae, *Lucifer faxoni*, *Acetes a. carolinae*, *Penilia avirostris*, *Doliolum sp.* and fish eggs and larvae were present in greatest abundance.

Surface and benthic nekton samples were obtained. Dredge samples were made quarterly and twelve invertebrate species and three species of fishes were collected. *Renilla mülleri* was the most abundant species taken, and the fish catch consisted of *Centropristes ocyurus*, *Citharichthys spilopterus* and *Etropus crossotus*.

Accounts of 50 invertebrate species (24,679 specimens) and 129 fishes (93,563 specimens) taken in trawl hauls is presented. Temperature and salinity data are given for all species. Relative abundance, seasonal bathymetric distributions and movements, apparent growth patterns, catch per unit of effort and various biological data are noted for the most abundant species. Station 5 (40 fathoms) produced the largest percentage of trawl catches (22.7). *Renilla mülleri* was the most abundant invertebrate taken in trawling. The brown shrimp, *Penaeus aztecus*, was second in abundance (10.92%). The five most abundant species comprising 80.57% numerically of the catch were croaker, longspine porgy, butterfish, spot, and seatrout. The species comprising 91.89% of the catch by weight were the croaker, longspine porgy, spot, seatrout, lizardfish, butterfish, pinfish, bank sea bass, sea catfish and black fin sea robin. The families Sciaenidae, Sparidae and Stromateidae were represented by the greatest numbers and comprised 82.9% of the total catch. Families considered to be of commercial importance contributed 92.9% to the total fish catch.

Introduction

Fishery resources in the Gulf of Mexico are primarily exploited in the estuaries and shallow continental shelf waters. Although most commercial species are estuarine dependent, the adults of many are harvested in Gulf waters. Systematic studies of the fauna in northern Gulf offshore waters east of the Mississippi Delta have not been made. There have been few such studies in other areas of the Gulf.

Gunter (1936 and 1945) carried out systematic sampling procedures in shallow Gulf waters out to the 10-fathom (18-meter) curve off Louisiana west of the Mississippi Delta (1931-33) and off Port Aransas in Texas (1941-42). He also carried out one concurrent sampling program in Mississippi estuarine waters, which is not yet published.

Moe and Martin (1965) made monthly trawl collections off Pinellas County, Florida out to the 17-fathom (31-meter) curve, but stations beyond 8 fathoms were rarely sampled successfully; their work covered a period of 8 months.

Miller (1965) collected regularly for 6 months at stations from 3 to 15 fathoms (5.5 to 27 meters) off Port Aransas, Texas.

Dawson (1966) carried out a 16-month ecological survey of the offshore waters of Grand Isle, Louisiana from 3.5 to 20 fathoms (6.4 to 36.6 meters). The major portion of his work is unpublished and is lost to science through a misconceived policy decision of legal advisers to the Freeport Sulphur Company.

Springer and Bullis (1952 and 1956) published species catch records for exploratory fishing catches of the *M/V Oregon I* in Gulf offshore waters. Siebenaler (1952) gave accounts of a few of the fishes taken in Mississippi offshore waters by the *M/V Oregon I*.

Hildebrand (1954 and 1955) reported on the fauna caught by shrimp trawlers on the brown and pink shrimp grounds off Texas

Roithmayr (1965) studied the catch of the industrial bottomfish fisheries in the northern Gulf.

Other works on the northern Gulf offshore fauna treat limited segments of the population.

Beginning in 1952 the industrial bottomfish fishery expanded rapidly and Roithmayr (1965) completed a sampling study of the industrial bottomfish catch from 1959-63. He reported the species

composition of commercial landings and areas and seasons of fishing, as well as measurements of catch, effort and bottomfish abundance.

Bottomfish landings in Mississippi reached a peak of 93.7 million pounds (42.5 million kg) in 1962 and then declined to a stable average of 60 to 70 million pounds (27–32 million kg).

About 64% of the shrimp catch between Mobile Bay and the Mississippi Delta is caught in Gulf offshore waters (Christmas, Gunter and Musgrave 1966).

The present work was designed to acquire information about the Gulf fauna off the Mississippi barrier islands in contradistinction to inside waters, by regular sampling at fixed stations out to the 50-fathom (91-meter) curve. The need for this information has been emphasized by expanding fisheries efforts in these waters.

A concurrent study of Mississippi estuarine areas was carried on. The estuarine study was incorporated in the Cooperative Gulf of Mexico Estuarine Inventory and Study (GMEI). The offshore project was amended to provide for electronic data processing of the acquired data in order to increase capability for correlation with the Cooperative program and to facilitate data analysis.

This report covers 29 months of collections at six fixed stations in a transect across the continental shelf off Mississippi. Trawl data have been stored in computer files.

Plans provided for monthly sampling of nektonic and benthic faunas with a 1-meter nekton net and a 40-foot (12-meter) balloon trawl. Plankton sampling was incorporated into the program later. Quarterly sampling of the sediments and associated infauna was also added later as an extension of the Cooperative GMEI sedimentology study.

Current summaries of all data were maintained throughout the study. When sampling was completed a backlog of plankton and nekton samples had accumulated because of the initial lack of proficient help. Project personnel continued work on these samples and started preparation of the manuscript for final project reports. This work was well advanced when Hurricane Camille hit the Mississippi Coast.

Project laboratory and offices were located in the "Big House" on the Laboratory grounds. This building, originally the residence of the owners of the property now occupied by the Laboratory, was built in 1900. The precaution of moving data files, equipment and samples to the second floor before Camille arrived was futile as is evident in Fig. 1.



Fig. 1. The "Big House" as it appeared before Hurricane Camille (August 1969), and as it appeared the day following.



Fortunately, trawl and hydrographic data were in EDP (computer) files and could be retrieved. What has been salvaged from nekton and plankton data, meager though it is, is included in this report.

Through cooperative efforts at no extra cost to the project, two dissertations were completed based upon data from plankton samples collected during project cruises. Mr. C. B. Subrahmanyam studied the penaeid shrimp larvae for his doctoral dissertation which degree was conferred on him by Mississippi State University in June 1969. Mr. Danny J. Acosta studied the offshore copepod fauna from the same samples. His Ph.D. was conferred by the University of Southern Mississippi in June 1970. Consequently, excellent data is now available for the study area on these two important groups.

One master's thesis was written from data on trawl collections made during this project. Mr. Allison Perry's study of the bottomfish collected in 1967 trawl hauls was accepted by the University of Mississippi as a Master of Science thesis. His degree was conferred in the summer of 1970.

The first offshore cruise was completed in January 1967. Seventy-three cruises were completed by May 1969. Cruises were scheduled to take advantage of favorable weather insofar as possible, but rough weather occasionally prevented the occupation of some stations. This occurred more often at the distant stations. The six stations were occupied a total of 245 times during the 29-month sampling period.

Station Location and Identification

The study area lies along a southeasterly transect across the continental shelf east of the Chandeleur Islands and the Mississippi River delta and south of the Mississippi Sound barrier island chain (Fig. 2). Six stations reaching from just south of Dog Keys Pass out to the 50-fathom (91-meter) curve were established. During field cruises stations were located from pre-determined co-ordinates with the aid of Loran readings. The number of day and night hauls made at each station during the study is shown in Table 1.

Station 1: 30°13'15" N. Lat., 88°47'30" W. Long.
Loran: 3H1-1108, 3HO-3598

Station 1 is the northernmost station lying approximately 1 3/4 miles south of the Dog Keys Pass Buoy, which is located near the western tip of Horn Island. This station lies in 5 fathoms (9 meters) of water. Twenty-nine day hauls and eighteen night hauls were made. Over

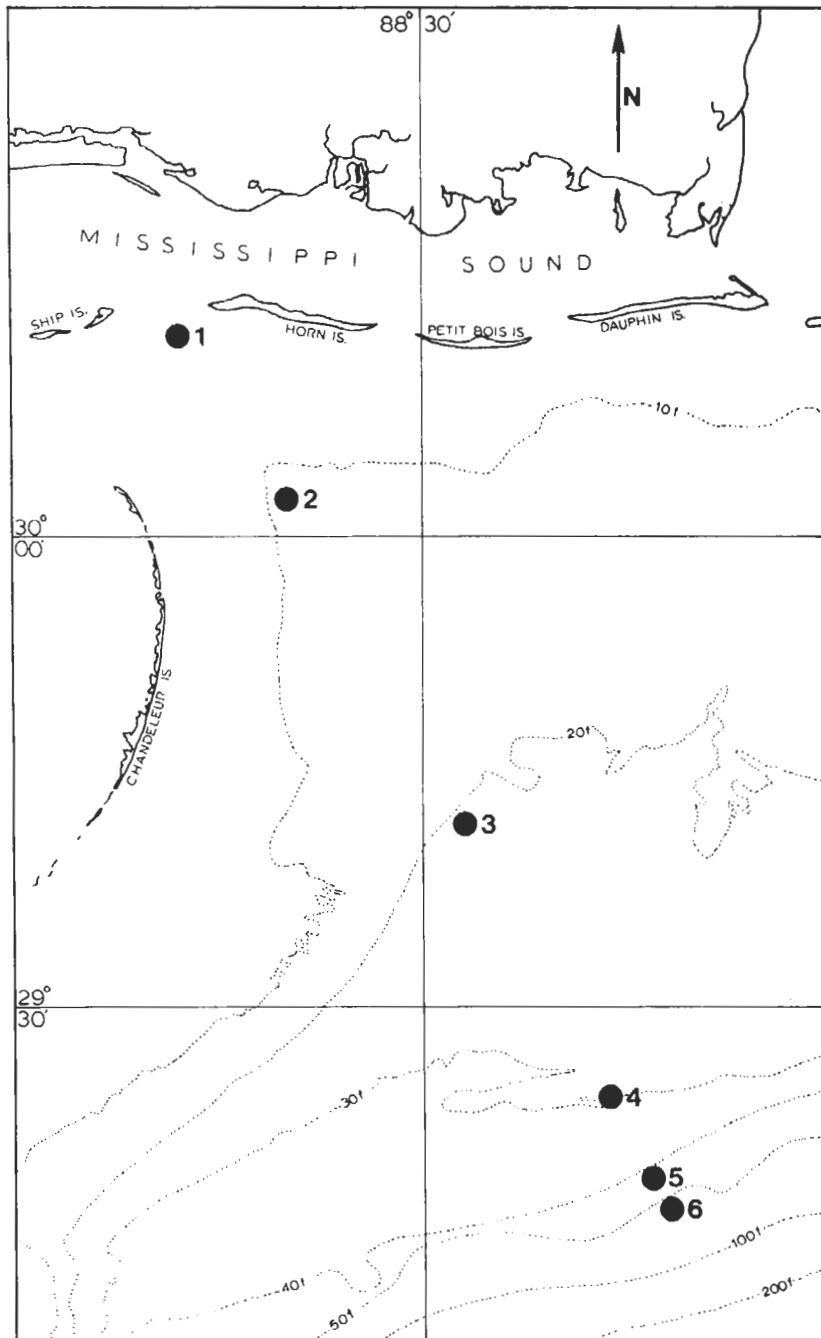

Fig. 2. Location of work, Project 2-42-R, showing station locations.

NEKTONIC AND BENTHIC FAUNAS

7

TABLE 1
NUMBER OF MONTHLY COLLECTIONS MADE AT THE OFFSHORE STA-
TIONS (1967-69)

MONTH	D-Day N-Night						Total D-N	Total Monthly
	Sta 1 D-N	Sta 2 D-N	Sta 3 D-N	Sta 4 D-N	Sta 5 D-N	Sta 6 D-N		
January	3-2	3-4	3-3	2-2	1-1	1-1	13-13	26
February	3-2	2-1	2-2	2-1	1-1	1-1	11-8	19
March	3-1	3-2	3-2	2-2	2-2	3-2	16-11	27
April	3-1	3-1	1-2	1-1	1-1	1-1	10-7	17
May	3-3	3-3	2-3	3-2	3-2	4-2	18-15	33
June	2-1	2-1	2-2	3-1	2-2	1-2	12-9	21
July	2-2	2-2	2-1	2-1	2-2	1-2	11-10	21
August	2-1	2-1	2-1	2-1	2-1	2-1	12-6	18
September	2-1	2-1	1-1	0-1	0-1	0-1	5-6	11
October	2-1	2-1	1-2	1-1	2-2	2-2	10-9	19
November	2-1	2-1	2-1	1-2	1-2	1-1	9-8	17
December	3-2	1-2	1-1	1-1	1-1	1-1	8-8	16
Total								
D-N	30-18	27-20	22-21	20-16	18-18	18-17	135-110	
Per/Sta	48	47	43	36	36	35		245

21% of all animals taken in trawl hauls were encountered at this station.

Station 2: 30° 02'30" N. Lat., 88° 40'15" W. Long.
Loran: 3H1-1220, 3HO-3580

Station 2 is located in 10 fathoms (18 meters) of water. Over 12% of the total trawl catch was taken here in twenty-seven day and nineteen night hauls.

Station 3: 29° 42'00" N. Lat., 88° 27'30" W. Long.
Loran: 3H1-1440, 3HO-3539

The 20-fathom (37-meter) station contributed 10.9% of the total trawl of fishes and invertebrates. A total of twenty-one day and twenty-one night hauls were made at this depth.

Station 4: 29° 24'15" N. Lat., 88° 17'00" W. Long.
Loran: 3H1-1618, 3HO-3494

Over 13.2% of the total trawl catch was taken at the 30-fathom (55-meter) depth. Nineteen day hauls and sixteen night hauls were made here during the study.

Station 5: 20° 19'00" N. Lat., 88° 14'00" W. Long.
Loran: 3H1-1657, 3HO-3480

Station 5 lies at the 40-fathom (73-meter) depth. In the course of the survey seventeen day and eighteen night hauls (Table 1) at this station produced 22.7% of the total trawl catch.

Station 6: 29° 17'15" N. Lat., 88° 12'05" W. Long.
Loran: 3H1-1683, 3HO-3472

Station 6 at 50 fathoms (91 meters) was the deepest station occupied. A total of seventeen day and seventeen night hauls were made here and catches comprised 19.5% of the total number of organisms collected.

Bathymetry

The shelf bottom along the transect is relatively smooth with a uniform slope of 3.4 feet per nautical mile for about 55 miles (101 kilometers). The slope increased to approximately 12.8 feet per nautical mile between 30 and 50 fathoms. Consequently stations located at 10-fathom intervals are closer together farther offshore. From Station 1 to Station 2 is about 12 nautical miles (22 kilometers); Station 2 to Station 3 is 23 nautical miles (43 kilometers); the distance between Stations 3 and 4 is about 22 nautical miles (41 kilometers). The distance between Stations 4 and 5 and between 5 and 6 is reduced to about 5.5 and 2.5 miles (10.2 and 4.6 kilometers) respectively (Fig. 3).

Materials and Methods

An effort was made to obtain monthly day and night trawl samples, monthly day and night nekton and plankton samples, and quarterly dredge samples from all established stations. Bad weather conditions sometimes hampered regular collecting procedure. The methods of collecting and the associated materials employed will be described separately under each phase of the collecting program.

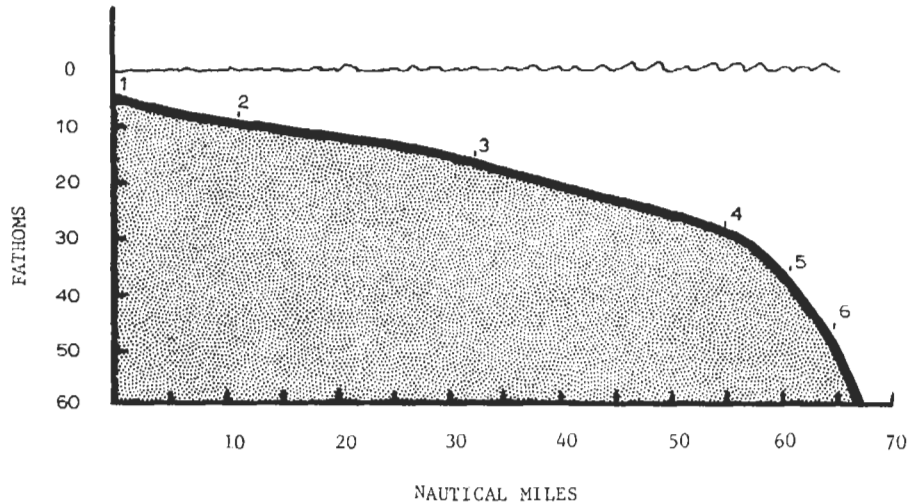

Fig. 3. Bottom profile along shelf transect, showing station location.

The offshore sampling was conducted aboard the *R/V Gulf Researcher*, a 65-foot (19.8-meter) wooden Navy T. Boat which was equipped for oceanographic research in 1963.

Information concerning individual sampling procedures and the physical data acquired was recorded on standardized field sheets on board the research vessel.

Water samples were obtained from three depths (surface, midwater, and bottom) each time a station was occupied. Surface samples were taken in a bucket, while midwater, and bottom samples were taken with a Nansen bottle. Surface water temperatures were taken with a Celsius thermometer. The midwater and bottom temperatures were taken by "fisheries-type" reversing thermometers which were attached to the Nansen bottles. Salinities were at first determined with Gemware sea water hydrometers; however, after the program had been in progress for 10 months an American Optical Goldberg Refractometer was employed for the determination of salinities (refractive index $\times 10^4$ - then changing to parts per thousand [ppt] by consulting a conversion table). This method was followed throughout the remainder of the program. Water samples were frozen on board for the purpose of chemical analysis later at the shore laboratory. These samples were tested for the presence of nitrates, nitrites, ortho-phosphates and total phosphates. Secchi disc (300 mm

diameter, white) readings were taken during day samples. Results were recorded to the nearest foot. Wind direction and speed, sea-state and movement of the tide were all recorded.

Processing of samples (measurements, weights, etc.) was carried out at the Gulf Coast Research Laboratory. All physical and trawl data were then transferred from field work sheets to GMEI formats.

Hydrology

There is now considerable hydrological information for the Gulf of Mexico. Galtsoff (1954) reviewed the history of systematic hydrographic studies. Important papers were first published about 1878. Leipper (1954) reviewed the physical oceanography of the Gulf of Mexico.

Collier (1958) presented extensive data from the *Alaska* cruises in the Gulf. Rivas (1968) gave monthly Gulf of Mexico mean surface isotherms and regional minima and maxima. Drennan showed surface circulation (1963) and sea surface temperature (1966) in the northern Gulf.

Despite the long history and extent of oceanographic study in the Gulf of Mexico, information about the shelf water remains relatively sparse. This is particularly true of the area considered in the present study.

Temperature and salinity data were collected throughout this project. Some analyses were completed for determination of the micro-nutrient parameters studied in GMEI projects.

Temperature

Monthly means of surface, midwater and bottom temperature and salinity observations for each station (depth) are shown in Table 2. These averages represent day and night samples. Diurnal differences were usually minor but day and night samples were not necessarily taken on the same day; consequently, monthly averages are very close to sample determinations.

Since data for all months are not available during calendar years 1967 and 1968, annual averages would not be comparable. Data are complete for the period June 1968 through May 1969, and monthly averages are shown for this period in Table 3.

NEKTONIC AND BENTHIC FAUNAS

11

TABLE 2
MONTHLY MEAN TEMPERATURE AND SALINITY BY STATION (DEPTH)

1967

	JAN	FEB	MAR	APR	MAY	JUN	JUL	AUG	SEP	OCT	NOV	DEC	YEAR
STATION 1													
SURFACE TEMPERATURE													
SURFACE	12.8	17.2	13.3	24.5	22.7	26.1	27.3	27.4	25.5	25.8	16.8	18.0	22.2
MIDWATER			13.3	23.1			26.9	26.2	25.9	24.4	16.8	17.7	22.5
BOTTOM	13.0	14.2	13.3	23.1	22.3	23.3	26.2	25.1	26.1	20.8	17.0	17.5	20.8
MIDWATER SALINITY													
SURFACE	30.7	28.6	33.6	26.3	26.1	28.9	31.4	31.6	26.7	33.1	32.9	35.2	30.1
MIDWATER			33.7	31.1			32.2	32.3	27.9	32.8	31.4	33.9	31.8
BOTTOM	31.2	32.3	33.7	31.9	32.7	29.8	33.0	35.9	31.0	33.3	32.4	31.9	32.4
STATION 2													
SURFACE TEMPERATURE													
SURFACE	14.5	14.2	15.6	24.8	24.7	26.5	27.8	26.9	25.5	22.5	19.4	18.9	21.8
MIDWATER			15.6	18.3			25.6	25.7	25.7	28.7	19.4	18.2	22.7
BOTTOM	15.5	14.8	15.8	18.3	22.7	25.3	21.7	25.1	28.9	20.2	19.5	18.8	20.8
MIDWATER SALINITY													
SURFACE	33.6	34.0	33.9	28.5	34.7	29.3	30.4	33.4	29.7	34.5	33.4	35.6	32.4
MIDWATER			34.7	35.5	35.5		33.7	34.3	31.2	34.6	35.1	32.1	33.9
BOTTOM	34.0	34.0	34.9	35.5	36.9	33.5	35.5	36.8	33.5	34.9	35.4	31.7	34.7
STATION 3													
SURFACE TEMPERATURE													
SURFACE	16.7	15.3	19.0		23.9	28.4	28.5	27.9		24.1	20.7		23.1
MIDWATER			17.8		20.8		25.7	23.8		23.8	20.4		22.1
BOTTOM	18.2	15.8	17.8		20.5	23.6	22.8	23.7		22.3	20.3		20.6
MIDWATER SALINITY													
SURFACE	36.0	34.0	35.2		33.8	32.5	28.0	34.7		36.5	36.4		33.7
MIDWATER			35.9		36.4		31.9	35.5		36.5	36.5		35.1
BOTTOM	36.9	34.0	36.3		37.3	35.1	36.7	36.8		36.7	36.8		36.1
STATION 4													
SURFACE TEMPERATURE													
SURFACE	18.9	16.9	20.7		22.0	28.8	28.1	27.6			22.4		24.7
MIDWATER			17.8			21.1	25.7	26.4			22.0		23.6
BOTTOM	18.6	16.4	20.0		21.2	24.0	24.9	25.2			22.0		22.4
MIDWATER SALINITY													
SURFACE	36.2	35.6	31.7		33.8	32.7	31.5	33.8			36.8		33.5
MIDWATER			36.6			37.1	32.7	35.3			36.8		35.2
BOTTOM	36.9	35.6	36.7		36.6	37.1	36.5	37.1			37.0		36.7
STATION 5													
SURFACE TEMPERATURE													
SURFACE			20.2		24.7	27.3	29.5	29.4		24.1	22.8		26.3
MIDWATER					20.3		26.1	28.1		23.4	20.0		24.3
BOTTOM			19.0		19.5	20.4	21.9	23.7		20.1	19.5		20.9
MIDWATER SALINITY													
SURFACE			32.7		34.0	36.0	27.8	34.7		37.1	36.6		33.5
MIDWATER					37.5		30.7	35.4		37.2	36.7		34.3
BOTTOM			36.2		36.6	35.7	36.9	37.0		37.4	36.8		36.6
STATION 6													
SURFACE TEMPERATURE													
SURFACE			20.5		23.8	29.2	29.2	29.6		24.6			26.4
MIDWATER					20.6	18.3	25.8	26.2		24.1			23.4
BOTTOM			20.0		19.7	19.4	19.7	25.0		22.4			20.9
MIDWATER SALINITY													
SURFACE			31.9		34.2	32.5	29.2	36.1		37.3			33.7
MIDWATER			37.8		36.7		32.7	37.0		37.1			35.9
BOTTOM			37.8		36.3	35.3	36.9	36.9		37.0			36.5

1968

	JAN	FEB	MAR	APR	MAY	JUN	JUL	AUG	SEP	OCT	NOV	DEC	YEAR
STATION 1													
SURFACE TEMPERATURE													
SURFACE	12.3	13.5	15.9	23.2	25.5	29.9	30.3	29.0	26.5	23.7	17.2	14.0	20.9
MIDWATER	12.6	11.7	15.4	25.0	25.0	31.0	29.7	29.0	26.0	22.7	17.3	14.2	20.8
BOTTOM	14.9	14.5	15.5	21.7	24.7	29.5	29.0	29.0	26.4	20.4	17.6	14.5	20.7
MIDWATER SALINITY													
SURFACE	26.2	28.0	25.8	13.1	33.0	26.0	17.7	22.4	27.4	36.5	36.1	32.0	28.3
MIDWATER	30.0	16.0	25.8	17.8	34.3	27.8	24.0	22.4	30.7	17.3	35.7	32.6	27.4
BOTTOM	27.3	28.5	25.8	32.4	36.7	28.8	26.9	28.2	26.6	36.2	36.1	34.3	31.5
STATION 2													
SURFACE TEMPERATURE													
SURFACE	13.9		16.6	22.4	25.1	29.5	29.9	29.6	28.9	25.1	19.5	16.2	22.7
MIDWATER	14.2		16.8	22.2	24.3	29.5	26.9	30.0	28.0	25.4	17.5	16.1	22.0
BOTTOM	16.0		17.1	20.2	20.6	24.0	27.0	29.0	27.6	24.9	22.2	16.1	21.8
MIDWATER SALINITY													
SURFACE	28.2		26.0	18.6	26.4	29.6	24.4	29.9	31.5	33.7	36.5	32.3	29.3
MIDWATER	26.2		23.6	24.2	27.3	21.4	25.2	29.9	32.4	33.7	36.5	33.2	29.1
BOTTOM	27.6		26.6	27.0	30.7	27.8	26.9	30.8	32.4	35.8	36.9	31.5	30.8
STATION 3													
SURFACE TEMPERATURE													
SURFACE	15.7		16.5	20.9	24.2	29.4	30.4	30.8	26.2	27.0	19.0	16.8	22.8
MIDWATER	17.5		16.5	19.0	23.5	25.0	30.4	31.0	27.9	28.1	16.7	17.2	24.7
BOTTOM	18.5		17.0	18.5	22.0	25.0	27.3	29.0	28.0	27.1	17.0	17.8	22.2
MIDWATER SALINITY													
SURFACE	30.0		24.0	19.6	24.2	37.7	29.0	21.6	34.4	34.7	36.1	33.1	30.8
MIDWATER	34.8		24.6	23.4	35.4	38.8	34.0	24.9	35.7	35.6	36.5	35.3	33.5
BOTTOM	30.4		24.6	25.2	34.4	37.0	29.8	29.9	33.6	37.3	37.4	34.4	32.9

Average temperature decreased from surface to bottom at all stations (Table 3). The greatest differences occurred at Stations 1 and 6. Differences increased with depth from 10 to 50 fathoms.

Surface temperature averaged 2.1°C higher at Station 6 than at Station 2, but Station 1, with the greatest estuarine influence, showed an average temperature 1.6°C higher than Station 2.

Average bottom temperature showed a maximum difference of 2.4°C between Station 3 and Station 6. There was only 0.1°C difference in the average bottom temperature at Stations 1 and 6.

Minimum temperature averages occurred in January at Stations 1 and 4 and in February at other stations (Table 3). The maximum average temperature (32°C) was found in June at Station 4. Maximum averages were found in July and August at other stations except for bottom observations at Station 5 where maxima occurred in August at the surface and in June at the bottom.

Seasonal differences (Table 3) were highest (17.4°C surface and 17.1°C bottom) at Station 1 and decreased with increasing depth. Seasonal temperature variations at the bottom were less than they were at the surface. The temperature at subsurface levels was often higher than at the surface.

Salinity

In Table 4 monthly average salinities are shown for surface, midwater and bottom samples. These averages were determined by the same calculations used for temperature. Average salinities (Table 4) clearly indicate that water in the study area is mixed with estuarine water much of the time. The highest annual average (34.3 ppt) occurred at the bottom in 50 fathoms of water.

During the study period, monthly average salinities ranged from 13.1 to 38.8 ppt (Table 4), a difference of 25.7 ppt. The maximum observation occurred at midwater (Station 3, June 1969). The lowest seasonal variation at any station was 10.3 ppt for bottom salinities at Station 2. At Station 1 the range of surface salinity was 23.4 ppt (Table 4). Minimum and maximum salinities, with one exception, did not occur in December, January and February at the surface or bottom. Apparently salinity in the study area was more stable in the colder months.

Minimum salinity had a range of 11.8 ppt at the surface and decreased to 6.8 ppt at the bottom. The range of maximum salinities varied from 1.2 at the surface and bottom to 3.1 at midwater. The surface salinity range decreased from 23.4 ppt at Station 1 to 14.2 ppt

TABLE 3
MINIMUM, MAXIMUM, RANGE AND MEAN OF MONTHLY AVERAGE TEMPERATURE FOR EACH STATION

Means are calculated for the period June 1968 - May 1969. Measurements are in C

Sta.	SURFACE				MIDWATER				BOTTOM				Range of Means
	Min.	Max.	Range	Mean	Min.	Max.	Range	Mean	Min.	Max.	Range	Mean	
1	12.9	30.3	17.4	23.6	13.3	31.0	17.7	21.2	12.4	29.5	17.1	19.0	4.6
2	13.9	29.9	16.0	22.0	14.2	30.0	15.8	21.8	13.4	29.0	15.6	21.1	0.9
3	15.4	30.8	15.4	23.2	15.1	31.0	15.9	22.7	15.0	29.0	14.0	21.3	1.9
4	15.2	32.0	16.8	23.5	15.0	27.0	12.0	21.6	14.6	27.0	12.4	19.9	3.6
5	16.3	30.4	14.1	23.9	15.7	29.2	13.5	22.1	16.0	25.7	9.7	19.9	4.0
6	16.4	30.4	14.0	24.1	16.0	29.8	13.8	22.1	16.3	21.9	5.6	18.9	5.2
Range	3.5	2.1	3.4	2.1	2.7	4.0	5.7	1.5	3.9	7.6	11.5	2.4	3.7

TABLE 4
MINIMUM, MAXIMUM, RANGE AND MEAN OF MONTHLY AVERAGE SALINITY FOR EACH STATION

Means are calculated for the period June 1968 - May 1969. Measurements are in ppt

Sta.	SURFACE				MIDWATER				BOTTOM				Range of Means
	Min.	Max.	Range	Mean	Min.	Max.	Range	Mean	Min.	Max.	Range	Mean	
1	13.1	36.5	23.4	27.6	16.0	35.7	19.7	27.9	25.2	36.7	11.5	28.2	0.6
2	18.6	36.5	17.9	31.0	21.4	36.5	15.1	30.3	26.6	36.9	10.3	32.3	2.3
3	19.6	37.7	18.1	31.4	23.4	38.8	15.4	30.8	24.6	37.4	12.8	33.1	2.3
4	24.9	36.8	11.9	32.3	25.0	37.4	12.4	33.4	20.2	37.9	17.7	32.0	1.4
5	17.4	37.1	19.7	31.1	23.2	38.0	14.8	32.0	23.2	37.8	14.6	32.6	1.5
6	23.2	37.4	14.2	32.9	21.6	37.8	16.2	33.8	27.0	37.8	10.8	34.3	1.4
Range	11.8	1.2	11.5	5.3	9.0	3.1	7.3	5.9	6.8	1.2	7.4	6.1	1.7

at Station 6 but variation of midwater and bottom salinities across the transect was irregular.

In general, salinities were lower inshore and higher on the bottom. The hydrology of the study area is complicated by an influx of fresh water from both Mississippi Sound and the Mississippi River as well as seasonal reversal of surface currents. Drennan (1966) showed that water from the eastern passes of the Mississippi River produces a hydraulic head extending 70-90 miles seaward. Very muddy water, apparently of Mississippi River origin was observed at the distant stations on some cruises.

Chemical Determinations

Some chemical analyses of water samples from this project were completed by GMEI personnel using standard GMEI methods. Concentrations of nitrates, nitrites, orthophosphates and total phosphates are shown in Table 5. All concentrations were expressed as microgram atoms per liter ($\mu\text{ga/l}$).

Two seasonal peaks of nitrate concentration were evident throughout the water column (Fig. 4) at all stations. The highest concentration was usually in January. Secondary peaks were evident in May at the surface and midwater and in July at the bottom. Nitrites were not detected.

Total phosphate concentrations were always at least one $\mu\text{ga/l}$. Seasonal peaks usually occurred when nitrates were low. Seasonal trends were similar at all stations throughout the water column. The highest total phosphate concentration (3.25) was found at Station 1 at midwater in May 1969 (Fig. 5).

Micronutrient concentrations in the top layers of open Gulf of Mexico water (Collier 1958) are usually very low in comparison with what we found in the study area.

Transparency

Transparency was measured with a secchi disc which met GMEI standards. Data for the period May 1968 through May 1969 are presented in Table 6.

The minimum observation was taken at Station 4 over 50 nautical miles from the barrier islands. The muddy water was very evident at this time as well as at Stations 5 and 6 in March and February with recorded readings of 24 and 20 feet, respectively. Maximum observations increased from 28 to 130 feet as distances offshore increased. Seasonal variations were irregular.

TABLE 5
MONTHLY MEAN NITRATE AND NITRITE BY DEPTH, JUNE 1968 - MAY 1969

Concentrations given as microgram atoms per liter ($\mu\text{g}/\text{l}$)

	JUN	JUL	AUG	SEP	OCT	NOV	DEC	JAN	FEB	MAR	APR	MAY
STATION 1												
-----NITRATE-----												
SURFACE	0.72	0.41	0.21		0.74			3.20	0.28	0.20	0.29	0.47
MIDWATER	0.73	0.41	0.18		0.22			0.84	0.28	0.20	0.26	0.45
BOTTOM	0.17	0.41	0.19		0.24			0.32	0.20	0.20	0.26	0.31
-----NITRITE-----												
SURFACE	0.00	0.00	0.00		0.00			0.00	0.00	0.00	0.00	0.00
MIDWATER	0.00	0.00	0.00		0.00			0.00	0.00	0.00	0.00	0.00
BOTTOM	0.00	0.00	0.00		0.00			0.00	0.00	0.00	0.00	0.00
STATION 2												
-----NITRATE-----												
SURFACE		0.52	0.24		0.28			2.96	1.12	0.76	0.49	0.31
MIDWATER		0.41	0.23		0.28			0.64	0.28	0.26	0.29	0.31
BOTTOM		1.75	0.29		0.24			0.64	0.28	0.10	0.28	0.31
-----NITRITE-----												
SURFACE		0.00	0.00		0.00			0.00	0.00	0.00	0.00	0.00
MIDWATER		0.00	0.00		0.00			0.00	0.00	0.00	0.00	0.00
BOTTOM		0.00	0.00		0.00			0.00	0.00	0.00	0.00	0.00
STATION 3												
-----NITRATE-----												
SURFACE		0.41	0.33		0.19			1.42		0.31	0.30	0.31
MIDWATER		2.46	0.31		0.18			2.56		0.31	0.31	0.29
BOTTOM		0.41	0.41		0.18			2.37		0.29	0.31	0.26
-----NITRITE-----												
SURFACE		0.00	0.00		0.00			0.00		0.00	0.00	0.00
MIDWATER		0.00	0.00		0.00			0.00		0.00	0.00	0.00
BOTTOM		0.00	0.00		0.00			0.00		0.00	0.00	0.00
STATION 4												
-----NITRATE-----												
SURFACE	0.86	0.63	0.33		0.22	0.15		7.24		0.31	0.28	0.28
MIDWATER	0.91	0.63	0.29		0.29	0.18		7.24		0.31	0.28	0.28
BOTTOM	0.12	0.84	0.23		0.22	0.18		7.40		0.31	0.28	0.28
-----NITRITE-----												
SURFACE	0.00	0.00	0.00		0.00	0.00		0.00		0.00	0.00	0.00
MIDWATER	0.00	0.00	0.00		0.00	0.00		0.00		0.00	0.00	0.00
BOTTOM	0.00	0.00	0.00		0.00	0.00		0.00		0.00	0.00	0.00
STATION 5												
-----NITRATE-----												
SURFACE	0.17	0.42	0.19		0.29	0.33		11.44		0.31	0.29	0.29
MIDWATER	0.35	0.42	0.18		0.29	0.29		1.96		0.31	0.31	0.29
BOTTOM	0.17	0.63	0.14		0.31	0.22		2.92		0.29	0.31	0.24
-----NITRITE-----												
SURFACE	0.00	0.00	0.00		0.00	0.00		0.00		0.00	0.00	0.00
MIDWATER	0.00	0.00	0.00		0.00	0.00		0.00		0.00	0.00	0.00
BOTTOM	0.00	0.00	0.00		0.00	0.00		0.00		0.00	0.00	0.00
STATION 6												
-----NITRATE-----												
SURFACE		0.63	0.21		0.74			2.40		0.29	0.31	0.29
MIDWATER		0.63	0.22		0.26			1.73		0.31	0.31	0.29
BOTTOM		0.84	0.18		0.24			2.16		0.31	0.31	0.29
-----NITRITE-----												
SURFACE		0.00	0.00		0.00	0.00		0.00		0.00	0.00	0.00
MIDWATER		0.00	0.00		0.00	0.00		0.00		0.00	0.00	0.00
BOTTOM		0.00	0.00		0.00	0.00		0.00		0.00	0.00	0.00

MONTHLY MEAN TOTAL PHOSPHATE AND ORTHOPHOSPHATE BY DEPTH
MAY 1968 TO MAY 1969

Concentrations given as microgram atoms per liter ($\mu\text{g}/\text{l}$)

	JUN	JUL	AUG	SEP	OCT	NOV	DEC	JAN	FEB	MAR	APR	MAY
STATION 1												
-----ORTHOPHOSPHATE-----												
SURFACE	1.03	0.44	1.10		1.05			0.50	0.50	0.50	0.50	0.50
MIDWATER	1.12	0.44	1.11		0.75			0.50	0.50	0.50	0.50	0.62
BOTTOM	1.08	0.44	1.21		0.50			0.50	0.50	0.50	0.50	0.50
-----TOTAL PHOSPHATE-----												
SURFACE	1.11	1.26	1.11		3.00			1.00	1.25	2.00	2.50	2.50
MIDWATER	1.26	1.26	1.22		3.02			1.00	1.25	2.25	2.50	3.25
BOTTOM	1.09	1.26	1.33		3.03			1.00	1.25	2.00	2.50	2.75
STATION 2												
-----ORTHOPHOSPHATE-----												
SURFACE		0.44	1.04		1.12			0.50	0.50	0.50	0.50	0.62
MIDWATER		0.93	1.06		1.17			0.50	0.50	0.50	0.37	0.62
BOTTOM		0.44	1.16		1.30			0.50	0.50	0.50	0.37	0.50
-----TOTAL PHOSPHATE-----												
SURFACE		1.33	1.16		2.35			1.00	1.00	1.50	2.75	3.00
MIDWATER		1.17	1.10		2.35			1.00	1.00	2.00	2.75	2.75
BOTTOM		1.07	1.24		2.72			1.00	1.00	1.75	2.75	2.50
STATION 3												
-----ORTHOPHOSPHATE-----												
SURFACE		0.37	1.17		0.50			0.50	0.50	0.62	0.62	0.62
MIDWATER		0.74	1.29		0.50			0.50	0.50	0.62	0.62	0.62
BOTTOM		0.37	1.33		0.62			0.50	0.50	0.62	0.62	0.50
-----TOTAL PHOSPHATE-----												
SURFACE		1.11	1.27		2.00			1.00	1.00	2.00	3.00	1.62
MIDWATER		1.11	1.38		1.75			1.00	1.00	2.50	3.00	2.00
BOTTOM		1.11	1.46		1.75			1.00	1.00	2.00	3.00	2.50
STATION 4												
-----ORTHOPHOSPHATE-----												
SURFACE	0.96	0.52	1.41		0.50	1.00		0.50		0.50	0.50	0.62
MIDWATER	0.98	0.52	1.43		1.00	1.00		0.50		0.50	0.50	0.50
BOTTOM	1.96	0.52	1.62		1.00	1.00		0.50		0.50	0.50	0.50
-----TOTAL PHOSPHATE-----												
SURFACE	1.11	1.04	1.47		2.00	2.00		1.00		2.50	2.50	2.75
MIDWATER	1.00	1.04	1.59		2.00	2.00		1.50		2.75	3.00	2.75
BOTTOM	2.01	1.04	1.81		2.00	2.00		1.00		2.50	2.50	3.00
STATION 5												
-----ORTHOPHOSPHATE-----												
SURFACE	1.42	0.52	1.11		0.75	0.50		0.50		0.75	0.50	0.50
MIDWATER	1.86	0.52	1.17		0.50	0.50		0.50		1.00	0.50	0.50
BOTTOM	1.93	0.52	1.18		0.50	0.50		0.50		0.75	0.50	0.50
-----TOTAL PHOSPHATE-----												
SURFACE	2.08	1.04	1.04		2.50	3.00		1.00		3.00	3.00	2.75
MIDWATER	2.01	1.09	1.71		2.50	2.00		1.00		3.25	3.00	2.75
BOTTOM	2.96	1.19	1.80		2.50	2.00		1.00		3.00	3.00	2.75
STATION 6												
-----ORTHOPHOSPHATE-----												
SURFACE		0.52	1.06		0.50	0.50		0.50		0.75	0.62	0.50
MIDWATER		0.52	1.13		0.50	0.50		0.50		0.75	0.62	0.50
BOTTOM		0.52	1.18		0.50	0.50		0.50		0.75	0.50	0.50
-----TOTAL PHOSPHATE-----												
SURFACE		1.30	1.10		1.75	1.00		1.00		2.50	3.00	2.75
MIDWATER		1.56	1.24		1.75	1.25		1.25		2.50	3.00	3.00
BOTTOM		1.56	1.24		1.75	1.25		1.25		2.75	3.00	3.00

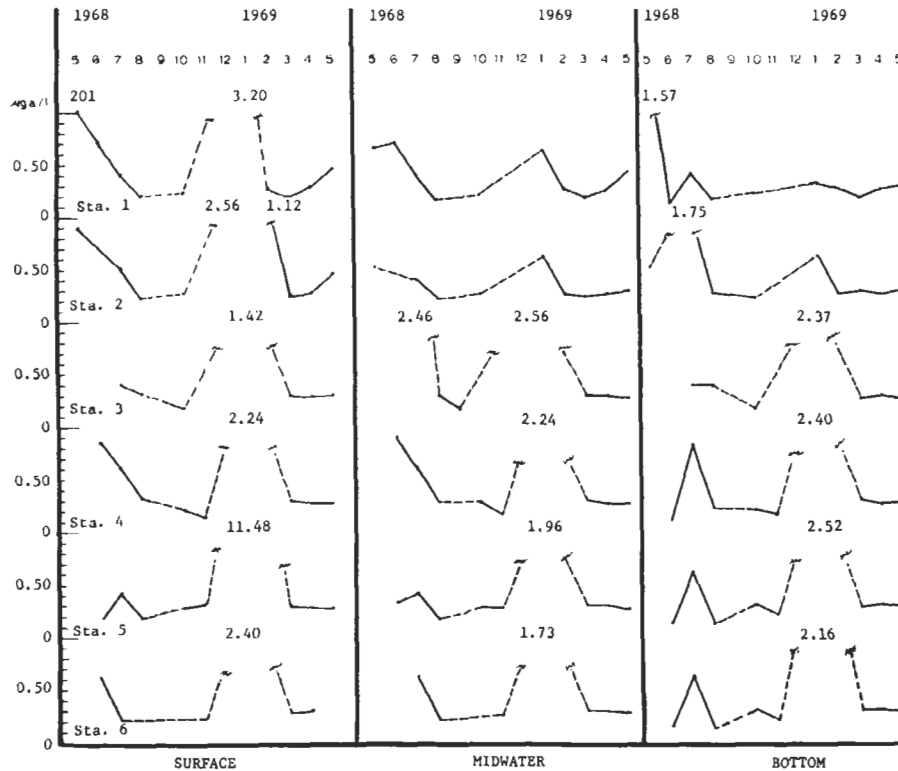

Fig. 4. Nitrate concentrations expressed in microgram atoms per liter for six offshore stations (May 1968 through May 1969).

Sedimentology

Background:

Sediments of the Mississippi and Louisiana coasts and in shallow offshore areas originally were derived from the Appalachian Mountains, the Rockies and the mid-continental U. S. Many of these sediments have undergone multiple cycles of erosion-deposition which cause the chemical and mechanical destruction of most poorly-resistant mineral grains. Debris eroded from the Appalachian Mountains is usually distinctive because it has been reworked more often and residual grains are the most resistant of minerals, e.g., quartz, rutile, zircon, staurolite, etc. The Rockies, a much younger mountain complex, contributed

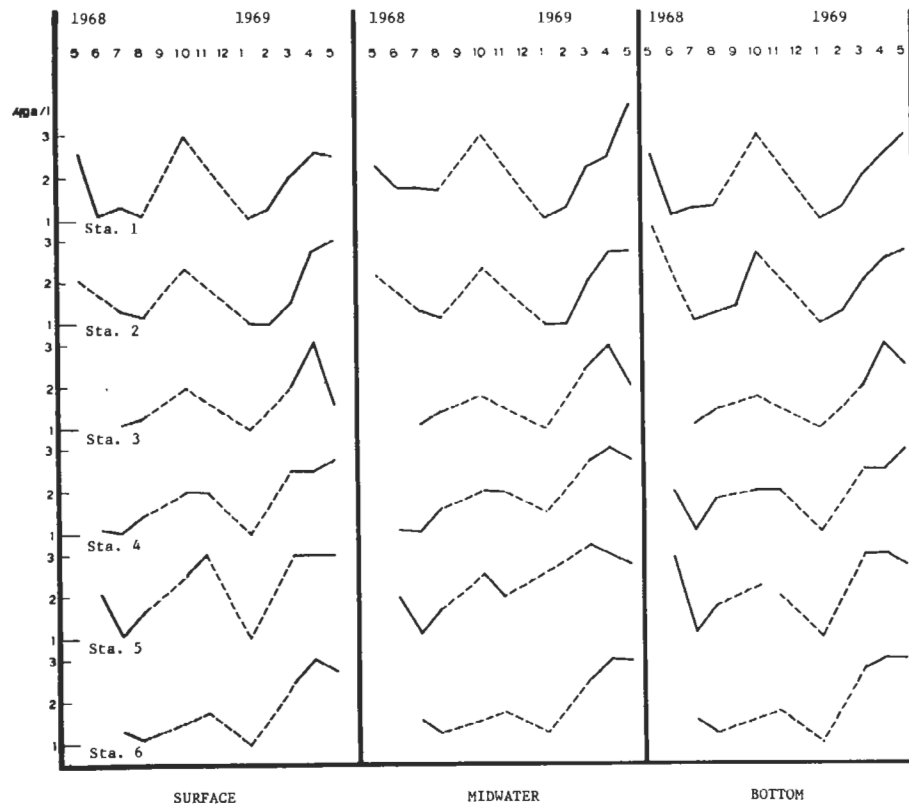

Fig. 5. Total phosphate concentrations expressed in microgram atoms per liter for six offshore stations (May 1968 through May 1969).

sediments that show less destructive breakdown. Sediments from the mid-continent are a mixture of debris ranging in age from ancient Precambrian to Pleistocene and Holocene with a varied mineral content. The heavy mineral content, i.e., minerals more dense than quartz (SG=2.65), renders the Appalachian suite distinctive.

Technique:

Samples of the bottom were taken by a Foerst grab at quarterly intervals four times during the project. Qualitative and quantitative analyses were performed in the laboratory.

Findings:

The qualitative analysis was made by binocular microscope and

shows the following:

Station 1. Silty mud with shell debris; fecal pellets; much organic matter; and a few foraminiferal tests.

Station 2. Sandy silt with some shell debris; many and varied foraminiferal tests; much organic matter; and some mica.

Station 3. Silty mud with little shell debris; much organic matter; many foraminiferal tests including pelagic forms; few echinoid spines; and some mica.

Station 4. Muddy, fine, well rounded sand; much shell debris with some fragments of gravel size; little organic debris; many foraminiferal tests; few echinoid spines; and mineral grains are polished.

Station 5. Variable bottom, at times a medium sand and at others a sandy mud; much shell debris; many and varied foraminiferal tests including pelagic forms; and few echinoid spines.

Station 6. Sandy clay with much shell debris; many and varied foraminiferal tests; few fecal pellets; and a trace of mica.

TABLE 6
MONTHLY TRANSPARENCY OBSERVATIONS AT OFFSHORE STATIONS
Observations are secchi disc extinction points in feet

Sta.	1968							
	May	June	July	Aug.	Sept.	Oct.	Nov.	Dec.
1	28		9	10	10	25	12	18
2	39	39	12	20	15	25	22	25
3			61	54	24	48	17	16
4	90	4	80	64		43	95	51
5	110	115	118	56		70	99	81
6	98		124	112		130	71	65

Sta.	1969				
	Jan.	Feb.	Mar.	Apr.	May
1	12	12		18	9
2	37	25	21	21	14
3	57	22	22	24	51
4	84	61	32	23	50
5	74	87	24	61	64
6	98	20	30	51	59

Quantitative analysis was made by pipette and sieve. The results may be seen in Table 7 and Fig. 6. The size name of sediments is shown in Fig. 6. Some terms used in Table 7 are:

- ϕ mean - average grain size in ϕ units.
- μ mean - average grain size in microns.
- μ sand mean - average size in microns of the sand particles only.
- $\sigma \phi$ - standard deviation in ϕ units, which is a measure of sorting.

The terms sand, silt, etc., are a designation of size only. These sizes are:

gravel		>2mm diameter
sand	<2mm and	>62.5 μ diameter
silt	<62.5 and	>3.9 diameter
clay	<3.9	

Sediment composition:

In offshore samples all the coarsest grains (<500 μ) were bio-authigenic, i.e. recently formed in or near the northern Gulf by biotic processes. In the coarser sand samples (125-500 μ) most of the grains had the same origin, either molluscan debris, small bryozoan colonies or foraminiferal tests. Allogenic mineral grains were small (<250 μ) and consisted largely of quartz fragments, mica, and minute traces of heavy minerals.

Size:

Theoretical expectations place coarsest sediments at Station 1 with a decreasing size gradient to Station 6; *in situ* samples do not conform with the theory (see Fig. 7). Stations 1, 2 and 3, closest to the mainland, show the finest sediments. Station 4 showed a consistently high percentage of sand throughout the sampling period. Station 5 was most variable; the sand content ranging from 12% to 90%; Station 6, the most distant from land, contained particles similar in size to Stations 1, 2 and 3.

The variations in grain size at the several stations may be attributed to Quaternary sea level changes, modified by recent depositional patterns. Continental glaciation, in the past, bound considerable quantities of water on land as ice, thereby lowering sea level. Estimates vary but maximum lowering may be conservatively estimated at 300-350 feet below today's sea level.

The presence of a sand body at Station 4 may indicate the presence of an ancient shoreline, covered so rapidly by rising water during the interglacial stage that the usual erosional processes did not destroy or disperse the sand body. Stations 1, 2 and 3 probably represent once emergent lands later covered by water and sediments brought in by rivers. In particular the Mississippi River appears to have contributed to this sediment cover; in the recent past (approximately 5000 yrs. B.C.) the Mississippi River flowed in an easterly direction,

TABLE 7
SEDIMENT PROPERTIES OF OFFSHORE STATIONS

Date	% Sand	% Silt	% Clay	ϕ Mean	μ Mean	μ Sand Mean	σ	Sorting
<u>Station 1</u>								
7/31/68		61	11	5.6	19.2	101	2	Very poor
11/20/68	44	26	30	5.6	19.2	100	2.6	Very poor
2/13/69	27.9	34.3	37.8	6.3	12.9	94	2.6	Very poor
5/15/69	19	43.8	37.2	6.45	11.5	91	2.5	Very poor
<u>Station 2</u>								
7/18/68	13	83	3	5.6	20	95	1.56	Poor
11/13/68	13	60	27	5.98	16.7	98	2.24	Very poor
2/13/69	5.4	57.5	37.1	6.69	9.8	93	2.21	Very poor
5/15/69	12.9	54.4	32.7	6.34	12.4	96	2.36	Very poor
<u>Station 3</u>								
7/30/68	18	78	4	6.14	14.2	101	1.81	Poor
11/13/68	20	34	46	6.66	9	112	2.4	Very poor
2/26/69	16.9	29	54.1	7.19	6.9	102	2.56	Very poor
5/29/69	20.5	35.5	44	6.74	9.4	97	2.58	Very poor
<u>Station 4</u>								
7/25/68	85	12	3	3.02	123	204	1.93	Poor
11/21/68	78	8	13	3.68	79	177	2.52	Very poor
2/26/69	84.2	2.9	12.9	3.63	81	156	2.5	Very poor
5/29/69	83.2	3.2	13.6	3.26	104	226	2.66	Very poor
<u>Station 5</u>								
7/25/68	89.8	5	5	2.49	178	267	1.92	Poor
11/21/68	12.9	30.1	57	7.2	6.1	109	2.1	Very poor
2/26/69	71.3	7.6	21.1	7.45		140	2.83	Very poor
5/28/69	55.4	11.8	32.8	5.36	24.4	138	3.07	Very poor
<u>Station 6</u>								
7/24/68	16	77	7	6.64	10	129	1.88	Poor
11/21/68	21.9	26	56.5	7.12	7.2	134	2.7	Very poor
2/26/69	25	20.2	54.8	7.11	7.2	125	2.8	Very poor
5/29/69	20.2	18.6	61.2	7.52	5.5	125	2.66	Very poor

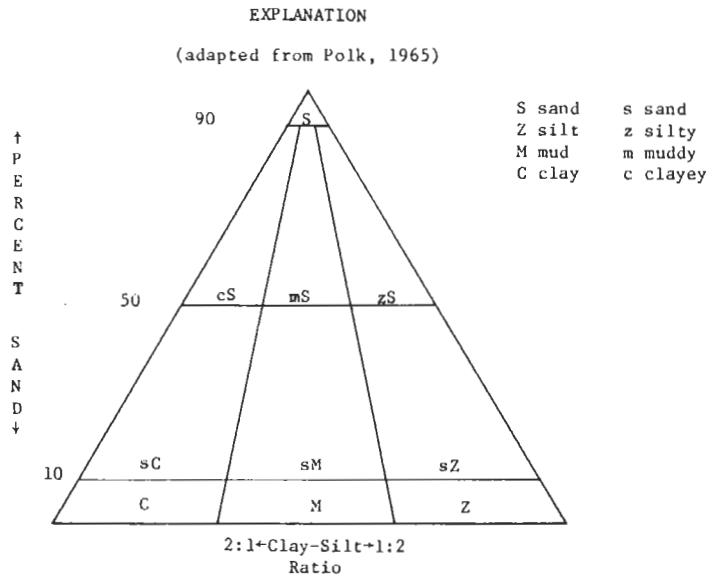

The small numbers within the triangles refer to the following times:

- 1 - Jul '68
- 2 - Nov '68
- 3 - Feb '69
- 4 - May '69

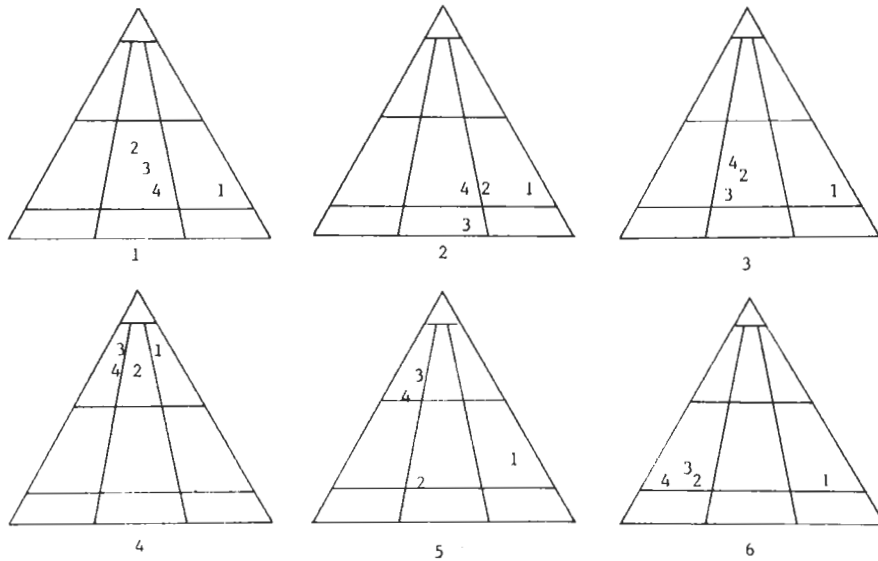

Fig. 6. Nomenclature for bottom sediments, based on grain size, at each station.

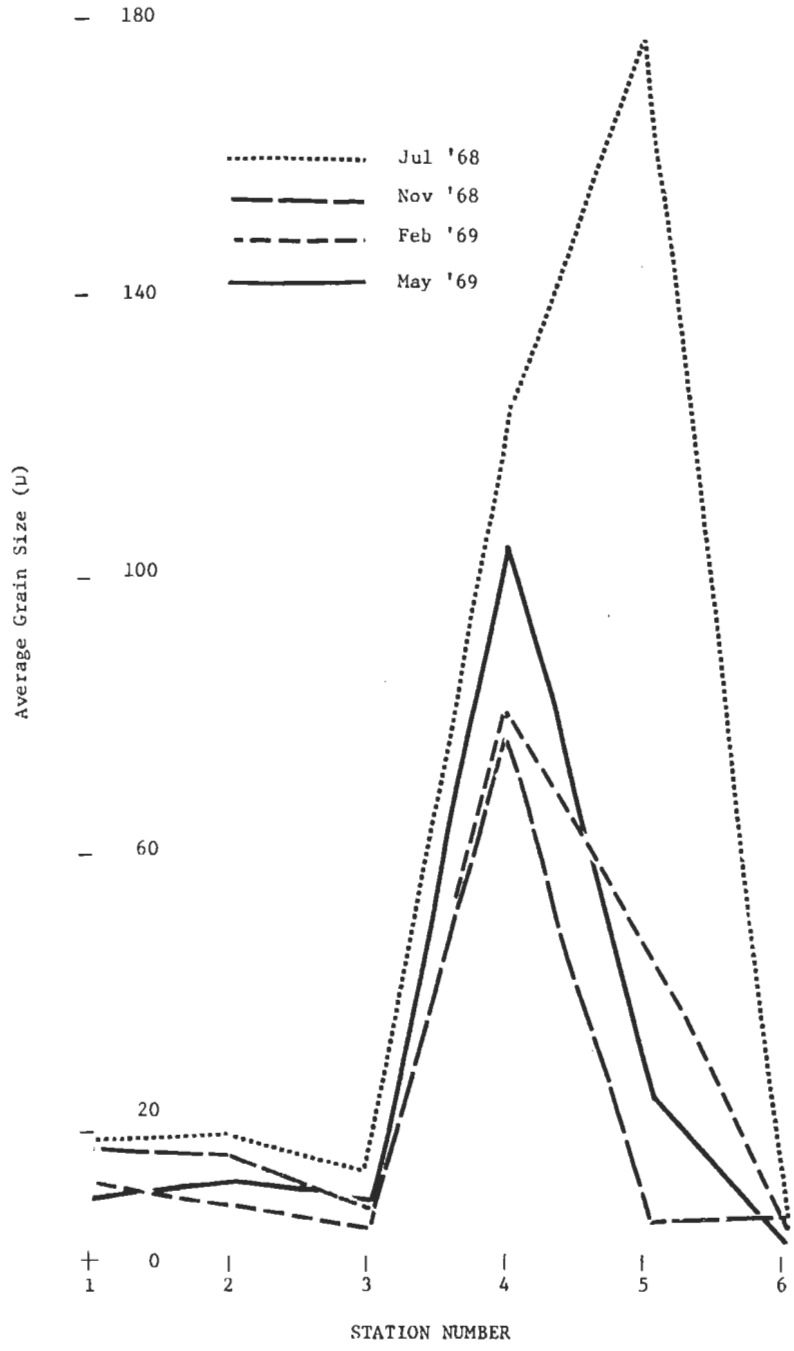

Fig. 7. Average grain size of bottoms of offshore stations.

building the St. Bernard delta complex. Today this complex is partially submergent, and its edge makes up the Chandeleur Islands. Downslope migration of mud and silt on the old delta front is filling the shallow offshore basin.

The extreme variability of sediments at Station 5 may be explained in one of two ways. Either navigational errors prohibited repeated return to the same spot, or the samples were taken at nearly the same spot and bottom conditions vary because of the downslope migration of sand waves. The bottom at Station 6 was the most consistent.

Foraminiferal populations followed expected trends with shallow-water forms found at Stations 1, 2 and 3, and deeper-water and pelagic forms found at 4, 5 and 6. At Stations 5 and 6 the presence of reef-dwelling foraminifera indicated presence of nearby reefs, and trawling produced dead corals and concretionary masses of mudstone. Many of the foraminiferal forms at these two stations seemed to be fossilized.

Plankton Sampling

A plankton sampling program was added early in 1968 and continued through May 1969. An effort was made to obtain monthly day and night plankton samples from all stations. Samples were collected from three depths (surface, midwater and bottom).

Collections were made with nets measuring 50 cm across the mouth and the length reaching from the mouth (including canvas) to the bucket was 200 cm. Number 3 nylon netting (mesh of 0.33 mm) was used.

The nets were fixed with underwater closing devices and were similar in design to that given by Hardy (1956). The net and associated closing device are shown in Fig. 8.

A surface net with a long nylon rope attached was towed from the stern of the boat. A bathythermograph winch (Model No. 1216 - BTW, Tacoma Boatbuilding Company) was used in hauling operations of the midwater and bottom nets which were secured on the same cable. A 60-lb. lead weight was shackled to the end of the towing cable before the nets were attached. This was done in order to increase stabilization of cable and nets, as well as to decrease the cable angle from the winch boom when the boat was underway and nets were open and "fishing". All nets were towed simultaneously at 600 rpm (approximately 2 knots) for a period of 20 min. In order to prevent a movement off

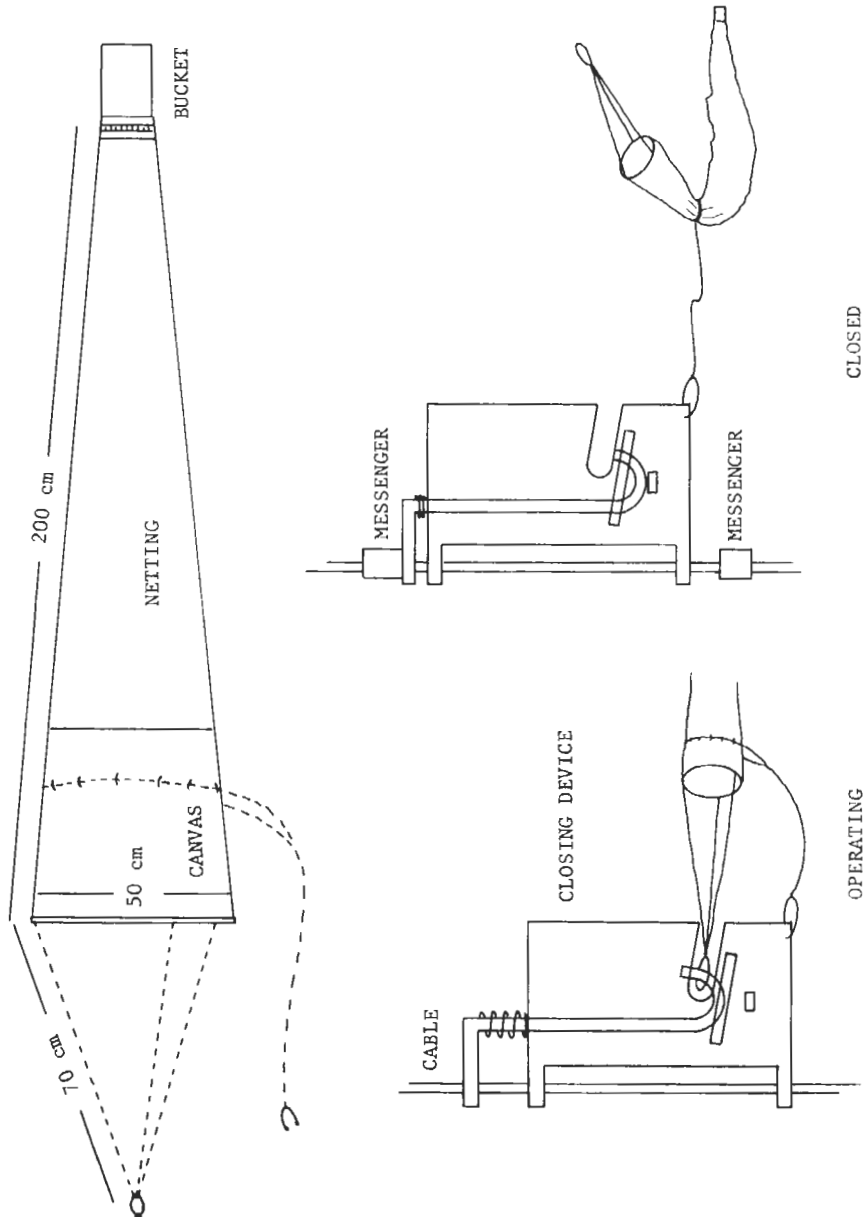

Fig. 8. Type of closing plankton net used in offshore sampling.

station, a circular towing course was always maintained. The required cable angle was determined at the beginning of each tow period and the calculated amount of cable was let out (cable length = depth x cosecant of wire angle). Then, immediately after the wire angle became rather constant, the length of cable was adjusted (depth = sine of wire angle x cable angle) to maintain the wire angle that would keep the bottom net approximately one meter off the bottom. Occasionally heavy seas or swift tidal movements altered the cable angle and compensations in cable length were made accordingly.

Closing of sub-surface nets was accomplished by using cable messengers (Fig. 8). When these nets were closed and were being hauled in the surface net was also brought aboard. Samples were labeled and preserved separately in 10% formalin.

As was previously mentioned in the introduction, progress had been made in the processing of the backlog of plankton samples by the summer of 1969. When the investigators were informed of the approach of Hurricane Camille, the majority of plankton samples and all

TABLE 8
NUMBER OF OFFSHORE PLANKTON SAMPLES EXAMINED

Station	Day	Night	Total
1: Surface	6	3	9
Mid-water	6	4	10
Bottom	5	4	9
2: Surface	9	1	10
3: Surface	3	4	7
4: Mid-water	4	-	4
Bottom	3	2	5
5: Surface	3	5	8
6: Surface	3	3	6
Bottom	<u>3</u>	<u>-</u>	<u>3</u>
Totals	45	26	71

plankton data forms were moved from the ground floor of the "Big House" to the second floor. This structure had weathered numerous severe hurricanes in the past and, for all practical purposes, the second floor of this building was considered to be safe storage area. Unfortunately, these samples and all data were destroyed during the storm.

A small number of plankton samples (71) had been placed in another building which received little damage and when laboratory facilities were partially restored the samples were examined. These few samples had previously been worked for penaeid shrimp larvae (Subrahmanyam 1971) and samples were checked only for abundant plankters. All salvaged samples had been collected in 1968 (March through December, Table 8).

Samples were allowed to settle and settled volumes were recorded. Entire samples were examined for commonly occurring forms and such forms were noted as being either few in occurrence, several or abundant.

The relative abundance of the common plankters, the months of their occurrence, corresponding temperatures and salinities at time of collection and settled volumes of samples are presented in Table 9.

Common Plankters

Phytoplankton

Phytoplankters were noted as abundant in four samples ranging from 5 to 40 fathoms. The majority were diatoms and on one occasion (Station 3 - October) a species of Chrysophyta was noted.

Zooplankton

COELENTERATA

This phylum was represented only by members of the class Hydrozoa.

HYDROZOA

The only identified species of this class was *Liriope tetraphyla*. Siphonophores occurred at the 5-, 10-, 20-, 40- and 50-fathom stations and were taken with only one exception (50 fathoms: bottom - night sample) in surface hauls. Siphonophorans were collected in several months (Table 9).

TABLE 9
SETTLED VOLUME, SALINITY, TEMPERATURE, AND RELATIVE
ABUNDANCE OF COMMON PLANKTERS

March to December 1968

(Numbers indicate total in sample; F-few; S-several; A-abundant; O-not observed;
D-day; N-night; S-surface; M-midwater; B-bottom)

STATION 1. 1968	Day										Night			
	Mar	Apr	May	Jun	Jul	Sep	Oct	Dec	May	Jul	Nov	Dec		
Settled Volume ml														
Surface	100	18	50	100	170	--	40	--	30	50	--	8		
Midwater	100	40	100	100	--	--	40	50	--	150	40	8		
Bottom	50	70	--	--	180	70	--	--	40	150	40	110		
Salinity ppt														
Surface	25.8	13.1	31.6	26.0	15.7	--	36.5	--	34.3	19.9	--	33.2		
Midwater	25.8	17.8	31.6	27.8	--	--	18.0	33.2	--	28.2	35.7	28.9		
Bottom	--	32.4	33.6	--	19.9	26.6	--	33.2	34.4	29.0	37.4	33.2		
Temperature C°														
Surface	15.9	23.2	26.0	29.9	30.4	--	23.5	--	25.0	30.3	--	13.9		
Midwater	15.4	25.0	25.2	--	31.0	25.0	--	14.1	--	29.4	18.6	14.4		
Bottom	--	21.7	24.0	--	29.5	26.4	--	14.5	20.3	26.4	19.4	16.3		
	Mar	Apr	May	Jun	Jul	Sep	Oct	Nov	Dec					
	D N	D N	D N	D N	D N	D N	D N	D N	D N	D N	D N	D N		
	SMB SMB	SMB SMB	SMB SMB	SMB SMB	SMB SMB	SMB SMB	SMB SMB	SMB SMB	SMB SMB	SMB SMB	SMB SMB	SMB SMB		
PHOTOPLANKTON	00-	000	000 0-0	00-	0-0 000	--0	00-	00-	00-	00-	00-	000		
COELENTERATA														
Siphonophora	00-	000	000 0-0	00-	0-0 000	--0	00-	00-	00-	00-	00-	000		
MOLLUSCA														
Gastropoda LAR	00-	000	000 4-0	00-	0-0 000	--0	00-	00-	00-	00-	00-	000		
ANNELIDA														
Polychata LAR	00-	000	004 0-0	00-	0-0 000	--0	00-	00-	00-	00-	00-	000		
ARTHROPODA														
Copepoda	AA-	FA0	AAA A-A	AA-	A-A AAA	--A	AA-	AA-	AA-	AA-	AA-	AAA		
Stomatopoda	00-	000	000 4-0	00-	0-0 000	--0	00-	00-	00-	00-	00-	000		
Stomatopoda LAR	00-	--AA	004 0-8	00-	0-0 040	--0	00-	00-	00-	00-	00-	000		
Caridea LAR	00-	000	000 0-0	00-	0-0 000	--0	00-	00-	00-	00-	00-	000		
Lucifer faxoni	00-	000	000 F-S	A0-	F-0 S00	--S	FF-	FF-	FF-	FF-	FF-	000		
Acetes a. carolinus	00-	0F0	000 F-0	00-	0-F 0SS	--0	0S-	0S-	0S-	0S-	0S-	000		
Anomura LAR	00-	S40	000 0-0	00-	0-0 00F	--0	00-	00-	00-	00-	00-	000		
Forcellanidae	00-	0S0	0A0 0-F	00-	0-0 00F	--0	00-	00-	00-	00-	00-	000		
Forcellanidae LAR	00-	00S	004 0-0	00-	0-0 000	--0	00-	00-	00-	00-	00-	000		
Forcellanidae ZOE	00-	S00	000 0-0	00-	0-0 000	--0	00-	00-	00-	00-	00-	000		
Faguridae MEG	0S-	000	000 0-4	00-	0-0 0S0	--0	00-	00-	00-	00-	00-	000		
Brachyura ZOE	00-	00S	S00 S-S	SF-	0-S S0A	--0	FA-	FA-	FA-	FA-	FA-	000		
Brachyura MEG	0S-	000	FAF S-0	80-	0-0 S00	--S	0Q-	0Q-	0Q-	0Q-	0Q-	000		
Pantilia avirostris	00-	FF0	F00 S-0	00-	0-0 000	--F	0A-	0A-	0A-	0A-	0A-	000		
CHAETOCNATHA														
Sagitta spp.	AA-	F00	AAA S-0	AA-	A-A AAO	--S	FF-	FF-	FF-	FF-	FF-	000		
TUNICATA														
Oikoplura sp.	00-	000	000 0-0	00-	F-F 000	--0	00-	00-	00-	00-	00-	000		
Doliolum sp.	00-	000	S00 0-0	00-	0-0 000	--0	00-	00-	00-	00-	00-	000		
Doliolum sp.	00-	F00	000 0-0	00-	0-0 000	--0	00-	00-	00-	00-	00-	000		
CEPHALOCHORDATA														
Osteichthyes EGG	00-	A00	00S 0-S	00-	F-0 000	--0	00-	00-	00-	00-	00-	000		
Osteichthyes LAR	00-	S00	00S 0-0	00-	4-0 000	--0	00-	00-	00-	00-	00-	000		
Clupeiformes LAR	00-	040	000 0-0	00-	0-0 000	--0	00-	00-	00-	00-	00-	000		
Clupeidae LAR	00-	000	000 0-8	00-	0-0 000	--0	00-	00-	00-	00-	00-	000		
Anguilliformes LAR	50-	000	000 0-0	00-	0-0 000	--0	00-	00-	00-	00-	00-	000		
Perciformes LAR	00-	040	000 0-0	00-	0-0 00A	--0	00-	00-	00-	00-	00-	000		
Bothidae LAR	00-	000	000 0-0	00-	0-0 00S	--0	00-	00-	00-	00-	00-	000		
STATION 2. 1968														
Volume														
Surface	140	40	300	50	400	21	3	3	18		40			
Salinity														
Surface	26.0	27.0	21.3	29.6	19.0	29.9	31.5	36.5	31.5		29.8			
Temperature														
Surface	16.6	20.2	24.8	29.5	29.8	29.6	28.9	20.6	16.2		30.1			
	Mar	Apr	May	Jun	Jul	Aug	Sep	Nov	Dec					
	D N	D N	D N	D N	D N	D N	D N	D N	D N	D N	D N	D N		
	S S	S S	S S	S S	S S	S S	S S	S S	S S	S S	S S	S S		
COELENTERATA														
Liriope tetraphylla	0 -	0 -	0 -	0 -	0 F	0 -	0 -	0 -	0 -	0 -	0 -	0 -		
MOLLUSCA														
Gastropod LAR	0 -	0 -	0 -	0 -	0 F	0 -	0 -	0 -	0 -	0 -	0 -	0 -		
Pteropoda	0 -	0 -	0 -	0 -	0 F	0 -	0 -	0 -	0 -	0 -	0 -	0 -		
ARTHROPODA														
Copepoda	A -	A -	A -	A -	A A	A -	A -	A -	A -	F -				
Stomatopoda LAR	0 -	F -	0 -	8 -	0 F	0 -	F -	0 -	0 -	0 -				

TABLE 9 (Continued)

	Mar	Apr	May	Jun	Jul	Aug	Sep	Nov	Dec
<i>Lucifer faxoni</i>	0	0	0	0	A -	0	0	0	0
<i>Acetes caroliniae</i>	0	0	F	0	0 S	0	F	0	0
Brachyura ZOE	0	S	0	F	0 S	S	0	A	0
Brachyura MEG	S	S	0	F	0 A	0	F	0	0
ECHINODERMATA	0	0	0	0	0 -	0	0	0	0
Ophiuroidea	0	0	0	0	1 -	0	0	0	0
CHAETOGNATHA	0	0	0	0	0	0	0	0	0
<i>Sagitta</i> spp.	F	A	A	A	0 A	A	A	A	A
TUNICATA LAR	0	0	0	4	0 -	0	0	0	0
<i>Gikopleura</i> sp.	0	0	F	0	0	0	0	0	0
CHORDATA	0	0	0	0	0 -	0	0	0	0
Osteichthyes EGG	0	0	0	0	0 -	0	0	0	0
<i>Anchoa</i> sp.	A	0	0	0	0 -	0	0	0	0
Perciformes LAR	0	0	0	0	0 -	0	0	0	0
STATION 3, 1968	Day			Night					
Volume ml	Mar	Jul	Sep	May	Jun	Oct	Dec		
Surface	80	40	150		100	70	50	100	
Salinity ppt									
Surface	24.0	29.0	35.7		24.2	37.7	34.7	33.2	
Temperature									
Surface	16.5	30.4	28.5		24.2	29.4	27.1	17.3	
	Mar	May	Jun	Jul	Sep	Oct	Dec		
	D N	D N	D N	D N	D N	D N	D N		
	S S	S S	S S	S S	S S	S S	S S		
THALLOPHYTA									
Chrysophyta	0	0 0	0	0	0 0	F 0	0		
COELENTERATA									
Siphonophora	0	A 0	0	0	0 S	0 0	A		
MOLLUSCA									
Gastropoda LAR	S	0 0	0	F	F 0	0 0	0		
Pteropoda	0	0 0	0	F	S 0	0 0	0		
ANNELIDA									
Polychaeta LAR	A	0 0	0	0	0 0	0 0	0		
ARTHROPODA									
Copepoda	A	0 0	A	A	0 0	0 A	0		
Caridea LAR	F	0 0	0	0	0 0	0 0	0		
<i>Lucifer faxoni</i>	0	0 0	F	A	F 0	0 A	0		
<i>Acetes a. caroliniae</i>	0	0 0	0	0	0 0	0 0	A		
Brachyura ZOE	0	0 A	F	A	0 0	0 0	A		
Brachyura MEG	0	0 A	F	0	S 0	0 A	0		
CHAETOGNATHA									
<i>Sagitta</i> spp.	S	0 A	S	A	0 0	0 A	A		
TUNICATA									
<i>Doliolum</i> sp.	0	0 0	0	0	0 0	0 0	A		
CHORDATA									
Osteichthyes EGG	0	0 S	0	0	F 0	0 0	0		
Osteichthyes LAR	0	0 4	0	0	0 0	0 0	0		
Synodontidae LAR	0	0 S	0	0	0 0	0 0	0		
Balistidae LAR	0	0 -	0	0	1 0	0 0	0		
STATION 4, 1968	Day				Night				
Volume ml	Jun	Jul	Oct	Nov	Sep	Oct			
Midwater	100	50	--	50	--	--			
Bottom	31	4	--	40	60	6			
Salinity									
Midwater	36.7	27.4	28.9	37.4	--	--			
Bottom	37.9	24.9	--	31.5	36.5	26.5			
Temperature									
Midwater	26.4	25.3	27.5	20.3	--	--			
Bottom	27.0	20.1	--	20.9	21.0	21.7			
	Jun	Jul	Sep	Oct	Nov				
	D N	D N	D N	D N	D N				
	MB	MB	MB	MB	MB				
MOLLUSCA									
Gastropoda LAR	00	00	-0	0-	-S	0F			
Pteropoda	00	00	-A	0-	-F	00			
ARTHROPODA									
Copepoda	AA	AA	-A	0-	-F	AA			
Stomatopoda LAR	00	00	-0	0-	-0	0A			
<i>Lucifer faxoni</i>	0S	0F	-0	0-	-0	00			
<i>Acetes a. caroliniae</i>	00	0F	-S	0-	-F	0A			
Porcellanidae ZOE	00	A0	-0	0-	-0	00			
Brachyura ZOE	SS	0S	-S	0-	-0	00			
Brachyura LAR	00	00	-0	0-	0S	00			
<i>Penilia avirostris</i>	S0	00	-0	0-	-0	00			

TABLE 9 (Continued)

	Jun	Jul	Sep	Oct	Nov				
CHAETOGNATHA									
<i>Sagitta</i> sp.	AS	AA	-S	0-	0F	AA			
TUNICATA									
<i>Doliolum</i> sp.	FO	AS	-0	0-	-F	00			
CHORDATA									
Osteichthyes EGG	00	00	-0	4-	-F	00			
Osteichthyes LAR	00	50	-0	0-	-0	00			
Anguilliformes									
LAR	00	00	-0	80	-0	00			
Perciformes LAR	00	00	-0	4-	-0	00			
<i>Cynoscion</i> sp.	00	00	-0	3-	-0	00			
<i>Lagodon rhomboides</i> LAR	00	00	-0	0-	-0	00			
Triglidae LAR	00	00	-0	4-	-0	00			
Heterosomata LAR	00	00	-0	0-	-0	00			
Bothidae LAR	00	00	-0	3-	-1	00			
STATION 5.									
1968	Day				Night				
	Jun	Aug	Dec	Mar	Jul	Sep	Oct	Dec	
Volume ml									
Surface	50	15	17	200	150	21	19	8	
Salinity ppt									
Surface	35.4	20.8	37.4	28.6	17.4	28.2	24.9	28.2	
Temperature									
Surface	29.1	30.4	21.6	18.0	29.9	27.1	27.7	21.7	
	Mar	Jun	Jul	Aug	Sep	Oct	Dec		
	D N	D M	D N	D N	D N	D N	D N		
	S S	S S	S S	S S	S S	S S	S S		
PHYTOPLANKTON									
COELENTERATA									
Hydrozoa	0	0	0	0	0	0	0	0	
Siphonophora	F	0	0	0	0	0	0	A	
MOLLUSCA									
Gastropoda LAR	0	4	0	0	0	0	0	F	
Pteropoda	F	0	0	S	0	1	S	F	
ANNELIDA									
Polychaeta LAR	F	0	0	F	0	0	0	0	
ARTHROPODA									
Copepoda	A	A	A	S	A	A	A	A	
Stromatopoda LAR	0	0	F	0	0	0	0	0	
Amphipoda	0	0	0	0	0	0	0	A	
<i>Lucifer faxoni</i>	0	0	0	S	S	F	1	0	
<i>Acetea a. caroliniae</i>	0	0	S	0	S	0	0	0	
Brachyura ZOE	F	4	0	0	0	0	0	S	
Brachyura MEC	0	0	S	0	0	F	0	0	
CHAETOGNATHA									
<i>Sagitta</i> spp.	S	A	A	A	A	F	0	A	
TUNICATA									
<i>Doliolum</i> sp.	0	0	0	0	0	F	A	F	
CHORDATA									
Osteichthyes EGG	0	0	0	A	0	0	0	0	
Osteichthyes LAR	0	0	4	0	0	0	0	0	
Clupeiformes LAR	0	0	A	0	0	0	0	0	
<i>Anchoa hepsetus</i> LAR	0	0	4	0	0	0	0	0	
Anguilliformes LAR	0	0	0	0	8	0	0	0	
Perciformes LAR	0	0	0	8	0	0	0	0	
Balistidae	0	0	0	0	8	0	0	0	
STATION 6.									
1968	Day				Night				
	Mar	May	Aug	Mar	Jun	Dec			
Volume ml									
Surface	60	71	5	140	22	21			
Bottom	20	4	30	--	--	--			
Salinity									
Surface	24.4	28.8	28.2	23.4	36.1	36.5			
Bottom	34.6	27.0	33.2	--	--	--			
Temperature									
Surface	18.8	25.5	30.4	17.8	25.3	20.8			
Bottom	15.6	20.5	21.9	--	--	--			
	Mar	May	Jun	Aug	Dec				
	D N	D N	D N	D N	D N				
	SB	SB S	SB S	SB S	SB S				
COELENTERATA									
Siphonophora	AF	S	00	0	FO	0			
MOLLUSCA									
Pteropoda	OF	0	00	0	OF	0			
ANNELIDA									
Polychaeta LAR	FA	0	40	0	OS	0			

TABLE 9 (Continued)

	Mar	May	Jun	Aug	Dec
ARTHROPODA					
Copepoda	AA A AA		S AA		S
Stomatopoda LAR	00 0 0A		0 S0		0
Amphipoda	00 0 00		0 02		0
Isopoda	00 0 00		0 00		1
<i>Lucifer faxoni</i>	00 F 00		S FO		S
<i>Aeetes a.</i>					
<i>carolinæ</i>	00 0 00		S 00		S
Brachyura ZOE	00 0 FO		0 OF		0
Brachyura MEC	00 F 05		0 00		0
<i>Penilia avirostris</i>	00 F OF		0 OF		0
CHAETOGNATHA					
<i>Sagitta</i> spp.	FF A AA		A AA		A
TUNICATA					
<i>Doliolum</i> sp.	00 0 FO		0 0A		0
CHORDATA					
Osteichthyes EGG	00 0 00		0 00		0
Osteichthyes LAR	0A 0 00		4 00		0
Clupeiformes LAR	00 0 03		0 00		0
<i>Caranx chrysoe</i>	00 0 00		1 00		0
Triglidae LAR	00 F 00		0 00		0

MOLLUSCA

GASTROPODA

Pteropods occurred at all stations except Station 1 (Table 9). Only pteropods of the order Thecosomata were collected. Temperatures and salinities ranged from 15.6° to 30.4°C and from 17.4 to 37.4 ppt respectively. Pteropods were taken only in surface and bottom samples. Unidentified gastropod larvae appeared often at most stations but never in abundance.

ANNELIDA

The only representatives of the phylum were polychaete larvae which appeared at temperatures ranging from 14.4° to 30.4°C and salinities from 20.8 to 35.7 ppt. Larvae were collected from all three levels of sampling (surface, midwater and bottom).

ARTHROPODA

The Crustacea was the only group of arthropods found in samples. Crustaceans were found to be the major components of plankton samples in both abundance and species diversification. The majority of specimens were identified only to higher taxa.

COPEPODA

Copepods were the major zooplankters in practically all samples examined, always being present in large numbers. Identifications were made only to the taxon Copepoda. Temperatures and salinities of collections in which copepods appeared ranged from 14.1° to 33.6°C

and from 13.1 to 37.9 ppt. Acosta (1970) studied the abundance, distribution and seasonal variation of copepods collected at our stations and the effects of salinity and temperature on selected species.

AMPHIPODA

Four small specimens appeared in a Station 5 surface (day) tow in December. The temperature and salinity were 21.6°C and 37.4 ppt.

Two specimens were taken in an August tow (bottom-day) from 50 fathoms. The temperature was 21.9°C, and the salinity was 33.2 ppt.

ISOPODA

A single specimen was noted in a December surface sample taken at night at Station 6. The temperature and salinity were 20.8°C and 36.5 ppt respectively.

STOMATOPODA

Stomatopod larvae occurred in many samples at all stations and from all sampling levels (Table 9). Larvae were taken at temperatures and salinities from 17.0° to 30.4°C and from 17.4 to 34.4 ppt respectively.

CARIDEA

Caridean shrimp larvae were noted in two samples; one from Station 1 (midwater-day) and the other from Station 3 (surface-day). The Station 1 specimens were taken in October at a temperature of 25.0°C and a salinity of 18.0 ppt. The Station 3 larvae were collected at a temperature of 16.5°C and a salinity of 24.0 ppt during the month of March.

SERGESTIDAE

Two sergestid shrimp, *Lucifer faxoni* and *Acetes americanus carolinae*, occurred together occasionally in the same samples. *Lucifer* was present in greater abundance than was *Acetes* and appeared at all three vertical sampling levels. *Lucifer faxoni* was taken at temperatures and salinities ranging from 14.5° to 30.4°C and 15.7 to 37.9 ppt respectively. Hopkins (1966) and Kelly and Dragovich (1968) noted that *L. faxoni* was more abundant at temperatures between 25.0° and 34.9°C in Florida. The majority of specimens observed in this study occurred from 28.0° to 30.4°C. Woodmansee (1966) reported on the vertical migration of *Lucifer* off Mississippi in relation to the solar and tidal cycles. *Acetes* was taken at temperatures ranging from 13.9° to

30.1°C and salinities from 21.3 to 37.4 ppt and appeared in samples obtained from all three sampling levels.

ANOMURA

Porcellanid larvae were taken seasonally from the three vertical levels and at the majority of stations (Table 9). These larvae were found in greatest abundance at the midwater and bottom depths. Temperatures and salinities ranged from 14.4° to 26.4°C and from 17.8 to 34.4 ppt respectively.

Pagurid megalops (four specimens) were encountered at 5 fathoms in a May sample (bottom-night). The temperature was 20.3°C, and the salinity was 34.4 ppt.

Other unidentified larvae were assigned to the taxon Anomura.

BRACHYURA

Brachyurans encountered were identified only to the taxon - Brachyura. Zoea and megalops were taken in the majority of samples and were considered to be abundant plankters in the examined samples. Zoea and megalops were found together on numerous occasions: isolated occurrences of both were noted (Table 9). Brachyuran zoea and megalops were taken at temperatures and salinities of 13.9° to 31.0°C and 17.4 to 37.9 ppt and were found at the surface, midwater and bottom sampling levels.

CLODOCERA

Penilia avirostris appeared in samples from 5, 30 and 50 fathoms and occurred at all sampling levels. Bigelow and Sears (1939) noted *Penilia* about 60 km off the New Jersey coast, and Marukawa (1921) found the species offshore east of Japan (230 to 310 km). These apparently constitute the greatest offshore distances recorded. Lockhead (1954) discussed the distribution of *P. avirostris* and noted its occurrence in larger numbers in coastal waters. *Penilia avirostris* is the only marine representative of the cladoceran tribe, Ctenopoda, and Lockhead (1954) discussed various life history aspects of the species.

Penilia has usually been reported from salinities higher than 32.0 ppt. A record from fresh water (Kramer 1895) is of notable interest. *Penilia* occurred in our samples at temperatures and salinities from 17.8° to 27.0°C and from 21.9 to 36.7 ppt. The majority of specimens were from salinities higher than 33.4 ppt.

ECHINODERMATA

OPHIUROIDEA

A single larval form was obtained in a July sample (Station 2, surface-day). The salinity was 19.0 ppt and the temperature was 29.8°C.

CHAETOGNATHA

Chaetognaths were second to copepods in general abundance. Unidentified species of *Sagitta* were noted and recorded. *Sagitta* was found in the majority of samples examined, and appeared at all levels. Temperatures were from 13.3° to 30.4°C and salinities ranged from 18.0 to 37.7 ppt.

UROCHORDATA

Doliolum was noted in numerous samples from 5 and 20 to 50 fathoms. Species identification was not made. *Doliolum* was found in various samples from all levels of collecting. Temperatures and salinities were 17.3° to 27.7°C and 13.1 to 37.4 ppt.

The other tunicate collected, *Oikopleura*, was not as abundant as *Doliolum* and occurred in only two of the examined samples (Station 1, surface-day; Station 2, surface-day). The Station 1 sample was taken in May, and the temperature and salinity were 26.0°C and 31.6 ppt. The specimens from 10 fathoms were collected also in May at a temperature of 24.8°C and a salinity of 21.3 ppt.

CEPHALOCHORDATA

In a midwater sample (night) in December at a temperature and salinity of 14.4°C and 29.9 ppt one cephalochordate was collected. The entire sample was examined, but only one specimen was found. This is an interesting record in the offshore plankton.

CHORDATA

OSTEICHTHYES

Larval fishes and fish eggs were found at all stations (5 to 50 fathoms). Identification of larvae has been carried out to the specific level when possible; however, the majority of larvae have been placed in higher taxa.

OSTEICHTHYES eggs

The majority of eggs were found in samples taken from May through October, with some eggs being taken in December.

OSTEICHTHYES larvae

Numerous larvae were identified only to class level. Larvae were quite abundant in several samples (Table 9).

CLUPEIFORMES

Several clupeiform larvae appeared at Stations 1, 5 and 6 and were taken from the three levels of sampling (surface, midwater and bottom) at these stations.

CLUPEIDAE

Clupeid larvae were encountered only in one of the examined samples (May, bottom-night). The temperature and salinity were 20.3°C and 34.4 ppt.

ENGRAULIDAE

Anchoa hepsetus (Linnaeus) appeared in one sample (40 fathoms, surface-night). The temperature was 29.9°C and the salinity was 17.3 ppt. Gunter (1945) noted a spring spawning season in Texas for *A. hepsetus*.

Anchoa sp.

Anchoa larvae were taken from Station 2 in March and July. March temperature and salinity were 16.6°C and 26.0 ppt. The temperature and salinity during the July period were 30.1°C and 29.8 ppt.

ANGUILLIFORMES

Leptocephalus larvae were found in samples from the 5-, 30- and 40-fathom stations. Temperatures and salinities ranged from 13.9° to 27.5°C and 25.8 to 33.2 ppt. These were presumed to be Anguilliformes but they were not critically examined.

MYCTOPHIFORMES

SYNODONTIDAE

Myctophiform larvae appeared in a surface (night) tow at Station 3 during May. The temperature was 24.2°C and the salinity was 24.2 ppt. These specimens were classified only as far as family.

PERCIFORMES

A number of larvae were not classified further than the major taxon - Perciformes. These larvae appeared in samples from Stations 1, 2, 4 and 5 (Table 9).

CARANGIDAE

A single young specimen of *Caranx crysos* (Mitchill) occurred in a June sample (Station 6, surface-night). The temperature was 17.8°C and the salinity was 23.4 ppt.

SCIAENIDAE

Cynoscion sp.

Small larvae (three specimens) of *Cynoscion* appeared in midwater (day tow) in October from Station 4 (Table 9). The temperature was 27.5°C and the salinity was 28.9 ppt. Seatrout (local species) probably spawn from spring through fall seasons (Pearson 1929, Gunter 1938a and 1945). Identification was carried only to the generic level on these small individuals.

Micropogon undulatus (Linnaeus)

A small number of *M. undulatus* larvae were taken in December at a temperature of 13.9°C and a salinity of 33.2 ppt. The sample was a surface (night) tow from Station 1 (Table 9). Pearson (1929) noted a spawning season from October to February in Texas for *M. undulatus*. Roithmayr (1965) suggested a spawning period from September to November in the northern Gulf.

SPARIDAE

A single larval specimen of *Lagodon rhomboides* was found in an October bottom (night) sample from 30 fathoms. Spawning in the Gulf from fall through winter has been suggested by several workers. Among these are Gunter (1945), Caldwell (1957), Springer and Woodburn (1960) and Cameron (1969). Spawning *L. rhomboides* were encountered in March during this study, and this is discussed in the trawl species account. The present occurrence of a larval form in October would indicate an early fall spawning of this individual. The temperature and salinity at the time of capture were 21.0°C and 36.5 ppt respectively (Table 9). Larvae were abundant in some GMEI samples during the winter and early spring.

TRIGLIDAE

Triglid larvae (four specimens) were encountered only in an October sample at a temperature and salinity of 27.5°C and 28.9 ppt. The sample was a midwater tow (day) from Station 4.

BOTHIDAE

Flounder larvae were found in July and October samples from Stations 1 (twelve specimens) and 4 (three specimens), respectively, at temperatures ranging from 21.7° to 26.4°C and salinities from 26.5 to 29.0 ppt (Table 9).

BALISTIDAE

Larvae of this family appeared only in two September samples. At Station 3 a surface (day) sample (one specimen) was taken at a temperature of 28.5°C and a salinity of 35.7 ppt. The other sample, a surface (night) tow at Station 5 (eight specimens) was made at a temperature of 27.1°C and a salinity of 28.2 ppt (Table 9).

Dredge Sampling

After 10 months of offshore sampling had been completed a dredging operation was added to the collection program in order to gain information concerning the infauna at the established stations. The first dredge hauls were made on 11 November 1967 and efforts were made to continue on a quarterly basis at all stations until the termination of the sampling period in May 1969.

Two vessels, the *Oregon I* and the *Silver Bay* (Bureau of Commercial Fisheries) have made only a limited number of dredge hauls in the area investigated during the offshore survey. The literature shows that information concerning dredging in Mississippi offshore waters is practically non-existent.

The dredge employed was a Peterson Biological Dredge. The dredge consisted of a nylon catch bag (mesh, 1 inch stretched) attached to a metal frame. The catch bag was covered by a sleeve of canvas to protect the webbing. The dredge weighed approximately 25 lbs. and measured 42 inches in length and 24 inches in width across the mouth. During periods of dredging the engine speed was maintained at 800 rpm, (approximately 2 knots) for a period of 20 minutes. This speed appeared to be the most practical for the biological dredge.

After bringing the dredge aboard, the catch was carefully sorted and preserved for shore identification. All samples were labeled as to station and sample number. In terms of both species diversification and abundance the infauna was quite sparse. The catches were primarily composed of species which do not burrow. This dredge apparently did not dig into the bottom very much.

A total of forty-three hauls were made. Only twenty-seven of these contained specimens. Those hauls devoid of living specimens were usually composed of mud, sand and shell fragments. Twelve invertebrate and three vertebrate species were collected. Table 10 presents all collected species with the respective dates of capture, station, number taken, temperature and salinity.

Species Account

1. *Renilla mülleri* was the most abundant species encountered in dredge samples. It occurred only at Stations 1 and 2 (a trawl record from Station 6 is discussed in the trawl species account) and appeared on twelve occasions (Table 10). *Renilla* was present during all seasons and was taken at temperatures and salinities ranging from 14.1° to 29.5°C and 24.9 to 36.5 ppt. Gunter (1950) found this species at temperatures ranging from 13.7° to 28.3°C and salinities ranging from 26.7 to 36.7 ppt. He indicated that these soft corals extended out to a depth of only 15 fathoms, which corresponds to the findings here.

2. Three species of polychaetes, *Branchioasychis americanus*, *Clymenella torquata* and *Diopatra cuprea*, were collected. *Branchioasychis americanus* was the most abundant of these. Polychaetes appeared only in February and September from 5 to 20 fathoms (Table 10). Bottom temperatures and salinities ranged from 14.5° to 26.4°C and from 26.6 to 28.5 ppt.

3. One mollusk, *Pecten papyraceus*, was taken in June from 50 fathoms at a temperature of 18.2°C and a salinity of 36.4 ppt.

4. The mantis shrimp, *Squilla empusa* appeared on three occasions, twice at Station 1 and once at Station 2. Twelve specimens were taken at a mean temperature and salinity of 22.5°C and 34.0 ppt. Another Stomatopod, *Squilla chydæa*, was collected from 50 fathoms in June at a temperature and salinity of 18.2°C and 36.4 ppt respectively.

5. *Callinectes similis* (eighteen specimens) was taken in all seasons at a mean temperature of 23.7°C and a mean salinity of 32.4 ppt.

In addition to *C. similis* four other decapod crustaceans (*Portunus*

TABLE 10
TOTAL DREDGE CATCH FROM SIX OFFSHORE STATIONS

Species	Date	Station	Salinity ppt	Temp. °C	No. Caught
Anthozoa					
<i>Renilla mulleri</i>	Nov 1967	2	35.4	19.5	18
	Jan 1968	1	28.5	14.8	34
	Feb 1968	1	28.5	14.5	50
	Apr 1968	1	32.4	21.7	50
	Jun 1968	1	28.8	29.5	100
	Jul 1968	1	34.0	28.5	25
	Aug 1968	1	28.2	29.0	54
	Nov 1968	1	36.5	16.4	68
	Nov 1968	2	26.5	14.4	68
	Jan 1969	1	32.1	14.1	100
	Apr 1969	1	34.9	19.5	85
	May 1969	1	24.9	22.0	300
	Mean.....		31.7	21.2	TOTAL 884
Polychaeta					
<i>Branchioasychis americanus</i>	Feb 1968	1	28.5	14.5	12
	Sep 1968	3	26.6	26.4	1
	Mean.....		27.6	20.5	TOTAL 13
<i>Clymenella torquata</i>	Feb 1968	1	28.5	14.5	8
<i>Diopatra cuprea</i>	Feb 1968	1	28.5	14.5	5
Pelecypods					
<i>Pecten papyraceus</i>	Jun 1968	6	36.4	18.2	1
Crustacea					
Stomatopoda					
<i>Squilla chydrea</i>	Jun 1968	6	36.4	18.2	1
<i>Squilla empusa</i>	Nov 1967	2	35.4	19.5	6
	Jul 1968	1	34.0	28.5	3
	Aug 1968	1	34.9	19.5	3
	Mean.....		34.0	22.5	TOTAL 12
Decapoda					
<i>Callinectes similis</i>	Nov 1967	2			1
	Jan 1968	4	31.5	20.9	2
	Apr 1968	1	32.4	21.7	1
	Jul 1968	2	27.7	24.9	1
	Jul 1968	1	34.0	28.5	3
	Aug 1968	1	29.0	28.2	3
	Sep 1968	3	35.7	28.0	3
	Nov 1968	4	37.4	18.2	1
	Apr 1969	4	36.4	18.2	3
	Mean.....		32.4	23.7	TOTAL 18
<i>Portunus gibbesi</i>	Mar 1968	6	34.6	15.6	3
<i>Portunus sp.</i>	Nov 1968	2	36.5	25.2	1
<i>Pagurus sp.</i>	Sep 1968	3	35.7	28.0	1
<i>Sicyonia brevirostris</i>	Nov 1968	5	38.2	21.6	3
	Jan 1969	5	34.9	16.1	1
	Feb 1969	5	33.5	16.9	1
	Mean.....		35.5	18.2	TOTAL 5
Osteichthyes					
Serranidae					
<i>Centropristes ocyurus</i>	Jun 1968	6	34.6	16.6	1
	Feb 1968	6	36.4	18.2	2
	Mean.....		35.5	17.4	TOTAL 3
Bothidae					
<i>Citharichthys epilopterus</i>	Jun 1968	5	38.7	26.5	4
	Jun 1968	6	36.4	18.2	1
	Jul 1968	2	24.9	27.7	1
	Apr 1969	5	37.4	19.5	1
	Mean.....		34.4	23.0	TOTAL 7
<i>Etropus crossotus</i>	Jan 1968	4	33.0	15.2	1

gibbesi, *Sicyonia brevirostris*, and unidentified specimens of *Portunus and Pagurus*) were collected (Table 10). *Sicyonia brevirostris* was taken from 40 fathoms, *Portunus gibbesi* from 50 fathoms, and the unidentified specimens of *Portunus* and *Pagurus* were from 10 and 20 fathoms respectively.

6. Two species of flatfish, *Citharichthys spilopterus* and *Etropus crossotus*, and three specimens of the sea bass, *Centropristes ocyurus*, were the only fishes represented in dredge hauls. *Citharichthys spilopterus* (seven specimens), was taken at 10, 40 and 50 fathoms. The temperatures ranged from 18.2° to 27.7°C, and the salinities ranged from 24.9 to 38.7 ppt. *Etropus crossotus* occurred only once (one specimen) at a temperature and salinity of 15.2°C and 33.0 ppt respectively. This fish was taken from 30 fathoms. *Centropristes ocyurus* was taken in June and February and only at 50 fathoms. The mean temperature was 17.4°C, and the mean salinity was 35.5 ppt.

Nekton Sampling

An investigation of the free-swimming marine animals which could be categorized as nekton was considered pertinent. In view of this, a nekton sampling program was established. Collections of surface nekton began at the onset of the project. Sampling of benthic nekton was added in December 1967.

Surface and benthic sampling were both accomplished using the same net. The net consisted of a stainless steel hoop one meter in diameter, with netting (1 1/2 inches stretched) attached to the hoop and trailing for a distance of 5 feet. The last 2 feet of the net near the cod end were made of fine mesh netting (1/8 inch stretched) to retain extremely small specimens.

The net was attached to a winch cable and towed on both occasions (surface and benthic) at an engine speed of 1,000 rpm (4 knots) for a period of 30 min. By knowing the towing cable angle and the depth of the water, the benthic nets were calculated to be "working" just above the bottom at the respective stations. Specimens were removed from the net and preserved for later identification. Each sample was labeled according to station and sample number.

An effort was made to obtain monthly day and night collections of surface and benthic nekton from all stations. A total of 245 surface and 152 benthic hauls were made. Haul information is presented in Table 11.

A total of 2,478 specimens representing thirty-one species from nekton hauls were included in the final report on this project for the

NEKTONIC AND BENTHIC FAUNAS

41

TABLE 11
a. SURFACE NEKTON HAULS

Station	Time	Number of Hauls		
		1967	1968	1969
1	Day	12	13	6
	Night	7	6	4
	Total.....	19	19	10
2	Day	11	12	5
	Night	9	5	5
	Total.....	20	17	10
3	Day	9	8	5
	Night	8	8	5
	Total.....	17	16	10
4	Day	8	6	5
	Night	5	7	5
	Total.....	13	13	10
5	Day	7	6	5
	Night	6	7	5
	Total.....	13	13	10
6	Day	6	6	5
	Night	6	7	5
	Total.....	12	13	10
Total Day Hauls		135		
Total Night hauls		110		
		245		

b. BENTHIC NEKTON HAULS

Station	Time	Number of Hauls		
		1967	1968	1969
1	Day	1	13	6
	Night	0	6	4
	Total.....	1	19	10
2	Day	-	12	5
	Night	-	5	5
	Total.....	-	17	10
3	Day	-	8	5
	Night	-	8	5
	Total.....	-	16	10
4	Day	-	6	5
	Night	-	7	5
	Total.....	-	13	10
5	Day	-	6	5
	Night	-	7	5
	Total.....	-	13	10
6	Day	-	6	5
	Night	-	7	5
	Total.....	-	13	10
Total Day Hauls		83		
Total Night Hauls		69		
		152		

period ending 30 June 1968. A number of larval and postlarval specimens had been backlogged for identification at this time. All offshore nekton (surface and benthic) work, as well as the laboratory in which the data were filed, was destroyed during Hurricane Camille.

It should be noted, however, that familiarity with the records gained from their processing previous to the hurricane (arrangement of species by stations, depth, time and month) in preparation for analyses of species catch data, as well as field observations, make possible a legitimate listing only of species which were commonly encountered and appeared to be in abundance. These species are presented in Table 12.

Trawl Sampling

Trawl samples were obtained with a balloon (otter) trawl measuring 40 feet in length and 4 feet from the cork line to the lead line. The netting was 1 7/8 in. stretched. Trawl boards measured 7 feet (length) by 4 feet (height). The trawl was worked through rigging on the forward starboard side, and a forward deck winch (Hydrographic Trawl Winch, Model No. 1216-HTW, Tacoma Boatbuilding Company) was employed in this operation.

Each trawling operation lasted for a period of 30 minutes (from the time the trawl winch was locked to prevent any further payout of cable until the commencement of "hauling-in"). Usually the 30-minute trawling time allowed for two, occasionally three, circular passes at the station area. The boat speed was maintained at 1,100 rpm (approximately 3 knots).

At the end of the 30-minute period the catch was hauled aboard and all captured specimens were taken from the net and sorted on the forward deck. Upon examination of the catch, if a species was represented by more than 100 specimens, selected members of this group totaling 100 were kept for shore laboratory work, and the remaining individuals were counted on board the vessel and usually discarded. If the total specimens of a particular species numbered 100 or less, all of these were retained. The majority of each catch was preserved in a separate barrel or plastic bags in 10.0% formalin and labeled with station and sample number. Barrels were lashed to the deck to prevent overturning during rough seas. Delicate invertebrates were preserved in individual bottles, and commercially important invertebrates were generally frozen. After specimens had been properly sorted, the deck was thoroughly washed in order to prevent contamination of the next sample with specimens of the previous catch.

TABLE 12
SPECIES MOST COMMONLY ENCOUNTERED IN NEKTON HAULS

Decapoda	Osteichthyes (continued)
Sergestidae	Mullidae
<i>Acetes americanus carolinae</i>	<i>Mullus auratus</i>
<i>Lucifer faxoni</i>	
Portunidae	Stromateidae
<i>Callinectes sapidus</i>	<i>Peprilus burti</i> Fowler
<i>Callinectes similis</i>	
<i>Portunus gibbesii</i>	Mugilidae
<i>Portunus sayi</i>	<i>Mugil cephalus</i>
<i>Ovalipes ocellatus</i>	
Osteichthyes	Atherinidae
Engraulidae	<i>Menidia beryllina</i>
<i>Anchoa hepsetus</i>	
Exocoetidae	Balistidae
	<i>Alutera scripta</i>
Gadidae	Tetradontidae
<i>Urophycis regius</i>	<i>Sphaeroides parvus</i>
	Leptocephali - Abundant
Syngnathidae	
<i>Syngnathus floridae</i>	
<i>Syngnathus scovelli</i>	

Laboratory Work on Samples

At the termination of a cruise all samples were taken off the boat and transported to the laboratory.

Each trawl sample was treated separately. Individual species were sorted and then measurements and weights were recorded on a standard work sheet. A measuring board marked in millimeters was used, and both standard and total lengths of fishes were recorded. Total length measurements are presented in species accounts with a few exceptions for badly damaged specimens. Measurements on certain invertebrates were not made. The majority of specimens were weighed and weights are presented in either grams or kilograms (large catches). Large specimens were weighed on Howe heavy-weight scales; however, most weights were recorded from a Precision Mettler Balance to the nearest tenth of a gram. For those species which were not taken in large numbers (100 or fewer per sample) an accurate total weight is presented. When a species appeared in large numbers per haul (100 or more), as was previously mentioned, only 100 representative specimens

were chosen, and the others were only counted. This method appeared to be practical since sizing every individual would have been quite time consuming. For those species taken in great abundance, an estimated total mass has been calculated using the formula:

$$\text{estimated total mass} = \frac{\text{total number caught}}{\text{number weighed}} \times \text{mass of weighed individuals.}$$

Data for the following accounts were taken from detailed tables computed by EDP. A reference collection was made during the study period. After a sample had been processed the majority of specimens were discarded. Reference material which had not been accessioned to the Gulf Coast Research Laboratory Museum was destroyed by hurricane Camille.

Comparisons of data from this survey with that of the Mississippi GMEI (Cooperative Gulf of Mexico Estuarine Inventory and Study) program were made and have been noted in the species account.

Systematic Account - Invertebrates

A total of 50 species (24,666 specimens) representing 40 genera and 27 families was collected. A phylogenetically arranged account is presented.

COELENTERATA

SCYPHOZOA

ULMARIDAE

Aurellia aurita Lamarck

Two hundred fifty large *A. aurita* were taken in one trawl haul at 10 fathoms in September. The temperature was 28.9°C and the salinity was 33.4 ppt. This species was occasionally observed in large numbers at the surface in the study area, but they were not seen at the surface when caught in the trawl. *Aurellia aurita* was not found in the GMEI samples and apparently is limited to high salinity water. These findings differ considerably from those of Gunter (1950) who took specimens in the back bays at salinities as low as 16.0 ppt.

ANTHOZOA

RENILLIDAE

Renilla mülleri Kölliker - Sea Pansy

There were 16,808 sea pansies taken at temperatures between 10.8° and 29.5° C and salinities between 24.9 and 39.8 ppt. Sea pansies were taken all year at GMEI stations in and near the passes into Mississippi Sound.

Gunter (1950) stated that there are no indications of any abundant populations beyond 15 fathoms. The majority of our samples showed major concentrations at 5 and 10 fathoms, with a small number taken in 1968 at 50 fathoms.

HORMATHIIDAE

Calliactis polypus - Anemone

Forty-nine individuals were caught at temperatures and salinities between 16.5° and 26.4° C and 23.2 and 34.9 ppt respectively. The depth was between 5 and 20 fathoms. *Calliactis polypus*, associated with hermit crabs, is common in Mississippi Sound near the barrier islands.

ACTINIDAE

Bunodactis sp.

A single unidentified specimen was taken in September at 50 fathoms in 1968. The temperature was 18.9° C and the salinity was 37.4 ppt.

Additional Observation - Coelenterata

Occasionally throughout each year *Physalia physalis*, Man-O-War, was observed offshore. These individuals were usually more abundant during and shortly after strong south winds. Sizes generally ranged from 25 to 250 mm (gas bladder length). Concentrations were commonly comprised of individuals of similar size. When southerly winds persist, the Man-O-War enters the adjacent estuary and often strands on the beach. Phillips, Burke and Keener (1969) indicated that this species feeds on small fishes, mainly anchovies.

MOLLUSCA

GASTROPODA

MELONGENIDAE

Busycon perversum Linné - Conch

Only one conch was acquired during the study. The rather large specimen appeared at 10 fathoms in July of 1967 at a temperature of 23.2° C and a salinity of 36.8 ppt. Moore (1961) noted that this species is the largest gastropod in Mississippi coastal waters. Abbott (1954) noted that *Busycon perversum* is an uncommon species found at depths from 4 to 10 fathoms. Gunter (1950) took three at 10 fathoms off the south Texas coast during 23 months of offshore trawling.

SCYLLAEIDAE

Scyllaea pelagica

Scyllaea pelagica was represented by two specimens. Both were taken in June of 1968 at 5 fathoms. The temperature was 29.5° C and the salinity was 28.8 ppt. *S. pelagica* was abundant in patches of *Sargassum* floating in the study area.

PELECYPODA

PECTINIDAE

Pecten papyraceus Gabb - Scallop

Two hundred twelve *Pecten papyraceus* were collected over the 3-year sampling period. These specimens were taken from depths of 30, 40 and 50 fathoms, with greatest concentrations at the 50-fathom station. Hildebrand (1954) noted that this species is commonly reported from 31 to 45 fathoms.

CEPHALOPODA

LOLIGINIDAE

Doryteuthis plei (Blainville) - Squid

Seventy-six specimens were caught at depths of 5 and 10 fathoms. Temperature and salinity ranges were 18.3° to 25.2° C and 27.0 to 37.4 ppt respectively. Lengths ranged from 95 to 189 mm (mantle length).

Lollinguncula brevis (Blainville) - Squid

A total of 926 individuals of this species was taken. Specimens were taken in all months and at depths ranging from 5 to 50 fathoms. The greatest numbers were obtained at the 5- and 10-fathom stations.

Gunter (1950) took 179 specimens from the Gulf at depths out to 10 fathoms. He noted that this squid is more common in the shallow Gulf than in the bays of Texas. However, this squid is abundant in inshore waters in Mississippi (GMEI data). Hildebrand (1954) made his largest catches of this species in depths out to 15 fathoms and noted an offshore movement during colder temperatures as evidenced by a large catch in January at 20 and 21 fathoms. Our data show an increase in numbers from December through April. Gunter (1950) took no specimens in bay waters during December and January.

The squid ranged in size from 20 to 160 mm (mantle length). Specimens under 40 mm were taken from October to April. The temperatures and salinities of collections ranged from 10.8° to 29.5°C and 24.9 to 39.8 ppt respectively (Table 13). Gunter's (1950) figures were 11.1° to 30.3°C and 17.7 to 37.2 ppt.

Loligo pealei Le Sueur - Squid

A total of 294 individuals was taken. They were collected in all months and in greatest numbers during March and April. Specimens were encountered from 5 to 50 fathoms and were in greatest numbers at 20 fathoms.

Gunter (1950) found this species only in the Gulf. Hildebrand (1954) found this squid quite abundant, and his largest hauls were from 14 to 18 fathoms in hauls completed at dawn. His catch per unit of effort was small at night, and our data are in agreement with this.

Our specimens ranged from 43 to 318 mm (mantle length) and the temperatures and salinities ranged from 12.0° to 29.0°C and 16.6 to 39.8 ppt respectively. Great numbers of this squid were occasionally seen around the boat at night and were apparently attracted by the lights.

SEPIOLIDAE

Rossia tenera (Verrill) - Squid

We collected one specimen of *Rossia tenera* at 5 fathoms in June at a temperature of 20.0°C and a salinity of 37.8 ppt. Hildebrand (1954) captured a single specimen at 23 fathoms.

OCTOPODIDAE

Octopus vulgaris Lamarck - Octopus

Octopus vulgaris was uncommon and appeared only twice, once in June of 1967 (30 fathoms) and again in July of 1968 (40 fathoms). The June temperature and salinity were 20.4°C and 37.8 ppt respectively.

TABLE 13
DISTRIBUTION OF *LOLLIGUNCULA BREVIS* BY BOTTOM SALINITY
AND TEMPERATURE INTERVALS SHOWING NUMBER OF SAMPLES,
CATCH PER UNIT OF EFFORT, MINIMUM, MAXIMUM AND MEAN
TOTAL LENGTH (MM).

		1967									
		SALINITY INTERVAL PPT									
TEMP	INT.	16.6	17.0	20.0	23.0	26.0	29.0	32.0	35.0	38.0	16.6
C		16.9	19.9	22.9	25.9	28.9	31.9	34.9	37.9	39.8	39.8
SMPLS.	10.8	0	0	0	0	0	0	0	0	0	0
CATCH	12.9										
MIN-MAX											
MEAN											
SMPLS.	13.0	0	0	0	0	0	1	6	1	0	8
CATCH	15.9						14,000	3,666	0,000		4,500
MIN-MAX							27- 55	35- 108			27- 108
MEAN							40.1	66.3			56.4
SMPLS.	16.0	0	0	0	0	1	1	4	13	0	19
CATCH	18.9					0,000	16,000	13,250	1,923		4,947
MIN-MAX							50- 93	27- 64	44- 76		27- 93
MEAN							62.8	46.8	59.0		52.8
SMPLS.	19.0	0	0	0	0	0	2	4	21	0	27
CATCH	21.9						1,900	5,000	3,238		3,370
MIN-MAX							72- 83	50- 93	20- 84		20- 93
MEAN							78.6	71.8	37.7		46.7
SMPLS.	22.0	0	0	0	0	0	1	1	12	0	14
CATCH	24.9						68,000	0,000	0,583		5,357
MIN-MAX							40- 87		38- 91		38- 91
MEAN							62.5		59.1		62.1
SMPLS.	25.0	0	0	0	0	0	4	2	18	0	24
CATCH	27.9						6,750	0,000	3,888		4,041
MIN-MAX							46- 90		50- 95		46- 95
MEAN							76.1		69.7		71.5
SMPLS.	28.0	0	0	0	0	0	0	2	0	0	2
CATCH	29.5							4,000			4,000
MIN-MAX								65- 85			65- 85
MEAN								76.6			76.6
SMPLS.	10.8	0	0	0	0	1	9	19	65	0	94
CATCH	29.5					0,000	14,222	5,421	2,615		4,265
MIN-MAX							27- 93	27- 108	20- 95		20- 108
MEAN							63.3	50.2	55.0		58.5

		1968									
		SALINITY INTERVAL PPT									
TEMP	INT.	16.6	17.0	20.0	23.0	26.0	29.0	32.0	35.0	38.0	16.6
C		16.9	19.9	22.9	25.9	28.9	31.9	34.9	37.9	39.8	39.8
SMPLS.	10.8	0	0	0	0	0	0	0	0	0	0
CATCH	12.9										
MIN-MAX											
MEAN											
SMPLS.	13.0	0	0	0	1	4	0	6	0	0	11
CATCH	15.9				4,000	23,750		8,500			13,636
MIN-MAX					51- 71	32- 98		39- 83			32- 98
MEAN					57.7	56.2		59.1			57.2
SMPLS.	16.0	0	0	0	2	2	3	6	8	0	21
CATCH	18.9				0,000	23,000	0,000	0,333	3,625		3,666
MIN-MAX						50- 86		84- 84	35- 95		35- 95
MEAN						65.3		84.0	64.1		65.1
SMPLS.	19.0	0	0	0	3	8	3	8	5	1	28
CATCH	21.9				0,000	0,000	0,000	1,500	0,000	0,000	0,428
MIN-MAX								41- 72			41- 72
MEAN								60.3			60.3
SMPLS.	22.0	0	0	0	0	2	0	2	4	0	8
CATCH	24.9					0,500		1,500	5,750		3,375
MIN-MAX						54- 54		56- 77	28- 78		28- 78
MEAN						54.0		70.0	51.6		53.7
SMPLS.	25.0	0	0	0	1	1	3	1	6	3	15
CATCH	27.9				0,000	0,000	20,333	0,000	1,500	0,000	4,666
MIN-MAX							52- 100		58- 80		52- 100
MEAN							95.2		67.8		84.5
SMPLS.	28.0	0	1	0	0	2	3	1	1	0	8
CATCH	29.5		0,000			9,500	3,666	0,000	0,000		3,750
MIN-MAX						57- 87	50- 100				50- 100
MEAN						70.6	75.8				72.5
SMPLS.	10.8	0	1	0	7	19	12	24	24	4	91
CATCH	29.5		0,000		0,571	8,473	6,000	2,833	2,941	0,000	4,021
MIN-MAX					51- 71	32- 98	50- 100	39- 84	28- 95		28- 100
MEAN					57.7	60.5	86.7	60.1	59.9		62.3

TABLE 13 (Continued)
1969

TEMP INT. C	SALINITY INTERVAL PPT									
	16.6 16.9	17.0 19.9	20.0 22.9	23.0 25.9	26.0 28.9	29.0 31.9	32.0 34.9	35.0 37.9	38.0 39.8	39.0 39.8
SMPLS. 10.8 CATCH	0	0	0	0	0	0	1	1	0	2
12.9 MIN-MAX							4.000	6.000		3.000
MEAN							28- 54	53- 78	28-	78
							41.0	60.6		52.8
SMPLS. 13.0 CATCH	1	0	0	2	1	7	6	1	0	18
15.9 MIN-MAX	0.000			5.500	14.000	4.571	1.000	0.000		3.500
MEAN				50- 96	44- 60	22- 80	52- 70			22- 96
				67.2	50.3	57.5	59.5			57.8
SMPLS. 16.0 CATCH	0	0	1	0	0	1	7	13	2	24
18.9 MIN-MAX			0.000			0.000	0.000	0.000	0.500	0.041
MEAN									80- 80	80- 80
									80.0	80.0
SMPLS. 19.0 CATCH	0	1	0	3	0	0	5	6	0	15
21.9 MIN-MAX		0.000		4.000			11.200	1.166		3.000
MEAN				55- 79			50- 88	63- 83	50-	88
				67.6			69.2	74.8		69.5
SMPLS. 22.0 CATCH	0	0	0	1	0	0	0	0	0	1
24.9 MIN-MAX				10.000						10.000
MEAN				58- 87						58- 87
				74.3						74.3
SMPLS. 25.0 CATCH	0	0	0	0	0	0	0	0	0	0
27.9 MIN-MAX										
MEAN										
SMPLS. 28.0 CATCH	0	0	0	0	0	0	0	0	0	0
29.5 MIN-MAX										
MEAN										
SMPLS. 10.8 CATCH	1	1	1	6	1	8	19	21	2	60
29.5 MIN-MAX	0.000	0.000	0.000	5.500	14.000	4.000	3.473	0.619	0.500	2.630
MEAN				50- 96	44- 60	22- 80	28- 88	53- 83	80- 80	22- 96
				69.5	50.3	57.5	66.6	68.3	80.0	64.1

In July the temperature was 19.2°C and the salinity was 23.2 ppt. A weight of 51.5 grams was recorded for the July specimen. Both specimens were small.

ARTHROPODA

CRUSTACEA

STOMATOPODA

SQUILLIDAE

Squilla chydrea Manning - Mantis shrimp

There were 126 specimens taken within a temperature range of 14.9° to 27.3°C and within a salinity range of 19.9 to 39.8 ppt. The depth range was from 20 to 50 fathoms. Individual total lengths ranged from 59 to 118 mm.

Squilla empusa say - Mantis shrimp

There were 628 *Squilla empusa* taken within a temperature range of 13.3° to 29.5°C and a salinity range of 23.2 to 39.8 ppt. Gunter's (1950) studies showed limits of 13.7°C to 25.4°C and 16.5 to 34.2 ppt.

The depth range of the specimens was from 5 to 50 fathoms, with the majority being caught in waters up to 40 fathoms. Only five were caught in 50 fathoms of water. Hildebrand (1954) found *S. empusa* to be more abundant in waters shallower than 30 fathoms. *Squilla empusa* is common in Mississippi Sound when the salinity is above 15.0 ppt (GMEI data).

DECAPODA

PENAEIDAE

Penaeus aztecus Ives - Brown shrimp

During the 3-year study period, 2,964 brown shrimp were collected. They were taken in all months and in all years. This species was collected at depths of 5 to 50 fathoms with the largest numbers obtained from 5 to 20 fathoms.

The largest catch per unit of effort was consistently encountered in night trawling. Osburn, Maghan and Drummond (1969) reported that the brown shrimp are caught at night by commercial trawlers with the largest catches made between 11 and 20 fathoms.

Young shrimp (under 100 mm) entered our catch in June, July, September, November and December. November produced the smallest individuals. This was probably due to the efflux of young shrimp from Mississippi Sound because of cooler water temperatures. Spawning of this species occurs throughout the year at temperatures above 17.0°C (Subrahmanyam 1971). Shrimp capable of spawning (above 140 mm, Berry and Kimsey 1964) were acquired in all months and the temperature requirements were met at some station during each month. Subrahmanyam (1971), whose study was run simultaneously with ours, found larval forms of this species throughout the year with peak concentrations in the spring and fall. Christmas, Gunter and Musgrave (1966) studied the seasonal occurrence and relative abundance of penaeid postlarvae in Mississippi Sound and adjacent waters, and discussed the prediction of future adult shrimp abundance from the numbers of juveniles in the bays following their larval immigration.

Length-frequency distribution shows a great deal of overlapping with only one size group distinct enough to allow an estimation of growth rate. A mode determined in November of 1967 was followed to March of 1968. This group was 56 mm in November and had reached 145 mm by March. Only one individual was taken in February of 1968; however, the minimum size range in February of 1969 was 115 mm. These data indicate a growth rate of 90 to 100 mm for 150 days. The growth rate was fastest during November of 1969 (from 55 to 85 mm) and diminished each succeeding month. This slowing of growth

probably is a result of the cooler water temperatures of December through March. Christmas and Gunter (1967) estimated the growth rate of postlarval and juvenile penaeids in Mississippi Sound and adjacent estuaries to be approximately 1.5 mm/day during the summer months. Data concerning the growth rate of penaeid shrimp in offshore waters is lacking. Our data show an average growth rate of 19 mm/month during the cooler months.

The temperatures and salinities of collections varied from 14.3° to 29.5°C and 24.6 to 39.8 ppt respectively. The salinity range that produced the greatest yield was 26.0 to 31.9 ppt, however, the majority of the individuals were taken at a salinity range of 35.0 to 37.9 ppt (Table 14).

The total weight of brown shrimp collected was 715 kilograms. July yielded the largest catch and the corresponding greatest monthly weight of 134.6 kilograms.

The brown shrimp is by far the most abundant shrimp in the Gulf of Mexico fishery. Osburn, Maghan and Drummond (1969) state that *P. aztecus* makes up 52% of the offshore shrimp fishery. Christmas and Gunter (1967) state that 5,276,000 pounds of brown shrimp were taken in 1963 from the offshore fishing grounds of Mississippi and southeastern Louisiana. In our samples the brown shrimp catch made up 80.8% of the total catch of commercial species of shrimp (*P. aztecus*, *P. fluviatilis* and *P. duorarum*) with white shrimp comprising 13.4% and pink shrimp comprising 5.8%. These percentages follow closely those reported by Christmas and Gunter (1967).

Penaeus duorarum Burkenroad - Pink shrimp

A total of 195 pink shrimp were collected. This species was taken at depths of 5 to 20 fathoms with the largest numbers taken in 5 fathoms. The catch per unit of effort was greatest at Stations 1 and 2 in night trawling. This shrimp was taken in May, June, August and October through January, with May showing the greatest catches. Pink shrimp were not collected in 1969.

Pink shrimp were encountered at temperatures and salinities ranging from 15.1° to 27.0°C and 26.2 to 39.8 ppt respectively. These shrimp ranged from 84 to 187 mm in length.

Christmas and Gunter (1967) reported that 499,000 pounds of pink shrimp were landed from the offshore fishing grounds of Mississippi and Southeastern Louisiana.

Osburn, Maghan and Drummond (1969) state that the pink shrimp makes up 22% of the total shrimp catch of the Gulf of Mexico with the

probably is a result of the cooler water temperatures of December through March. Christmas and Gunter (1967) estimated the growth rate of postlarval and juvenile penaeids in Mississippi Sound and adjacent estuaries to be approximately 1.5 mm/day during the summer months. Data concerning the growth rate of penaeid shrimp in offshore waters is lacking. Our data show an average growth rate of 19 mm/month during the cooler months.

The temperatures and salinities of collections varied from 14.3° to 29.5° C and 24.6 to 39.8 ppt respectively. The salinity range that produced the greatest yield was 26.0 to 31.9 ppt, however, the majority of the individuals were taken at a salinity range of 35.0 to 37.9 ppt (Table 14).

The total weight of brown shrimp collected was 715 kilograms. July yielded the largest catch and the corresponding greatest monthly weight of 134.6 kilograms.

The brown shrimp is by far the most abundant shrimp in the Gulf of Mexico fishery. Osburn, Maghan and Drummond (1969) state that *P. aztecus* makes up 52% of the offshore shrimp fishery. Christmas and Gunter (1967) state that 5,276,000 pounds of brown shrimp were taken in 1963 from the offshore fishing grounds of Mississippi and southeastern Louisiana. In our samples the brown shrimp catch made up 80.8% of the total catch of commercial species of shrimp (*P. aztecus*, *P. fluviatilis* and *P. duorarum*) with white shrimp comprising 13.4% and pink shrimp comprising 5.8%. These percentages follow closely those reported by Christmas and Gunter (1967).

Penaeus duorarum Burkenroad - Pink shrimp

A total of 195 pink shrimp were collected. This species was taken at depths of 5 to 20 fathoms with the largest numbers taken in 5 fathoms. The catch per unit of effort was greatest at Stations 1 and 2 in night trawling. This shrimp was taken in May, June, August and October through January, with May showing the greatest catches. Pink shrimp were not collected in 1969.

Pink shrimp were encountered at temperatures and salinities ranging from 15.1° to 27.0° C and 26.2 to 39.8 ppt respectively. These shrimp ranged from 84 to 187 mm in length.

Christmas and Gunter (1967) reported that 499,000 pounds of pink shrimp were landed from the offshore fishing grounds of Mississippi and Southeastern Louisiana.

Osburn, Maghan and Drummond (1969) state that the pink shrimp makes up 22% of the total shrimp catch of the Gulf of Mexico with the

TABLE 14
DISTRIBUTION OF *PENAEUS AZTECUS* BY BOTTOM SALINITY AND
TEMPERATURE INTERVALS SHOWING NUMBER OF SAMPLES, CATCH
PER UNIT OF EFFORT, MINIMUM, MAXIMUM AND MEAN TOTAL
LENGTH (MM).

1967

TEMP INT. C	SALINITY INTERVAL PPT									
	16.6 16.9	17.0 19.9	20.0 22.9	23.0 25.9	26.0 28.9	29.0 31.9	32.0 34.9	35.0 37.9	38.0 39.8	39.8 39.8
10.8 CATCH	0	0	0	0	0	0	0	0	0	0
12.9 MIN-MAX MEAN										
13.0 CATCH	0	0	0	0	0	1	6	1	0	8
15.9 MIN-MAX MEAN						0.000	0.833	0.000		0.625
16.0 CATCH	0	0	0	0	1	1	4	13	0	19
18.9 MIN-MAX MEAN					28.000	100.000	2.750	6.384		11.684
19.0 CATCH	0	0	0	0	0	2	4	21	0	27
21.9 MIN-MAX MEAN					0.500	1.750	5.333			4.444
22.0 CATCH	0	0	0	0	0	1	1	12	0	14
24.9 MIN-MAX MEAN					0.000	0.000	0.000	9.333		8.000
25.0 CATCH	0	0	0	0	0	4	2	18	0	24
27.9 MIN-MAX MEAN						49.250	1.500	12.444		17.666
28.0 CATCH	0	0	0	0	0	0	2	0	0	2
29.5 MIN-MAX MEAN							19.000			19.000
10.8 CATCH	0	0	0	0	1	9	19	65	0	94
29.5 MIN-MAX MEAN					28.000	33.111	3.368	6.169		9.797
					87- 147	95- 177	75- 194	56- 242		56- 242
					112.8	132.8	137.8	157.2		147.0

1968

TEMP INT. C	SALINITY INTERVAL PPT									
	16.6 16.9	17.0 19.9	20.0 22.9	23.0 25.9	26.0 28.9	29.0 31.9	32.0 34.9	35.0 37.9	38.0 39.8	39.8 39.8
10.8 CATCH	0	0	0	0	0	0	0	0	0	0
12.9 MIN-MAX MEAN										
13.0 CATCH	0	0	0	1	4	0	6	0	0	11
15.9 MIN-MAX MEAN				0.000	1.250		3.833			2.545
16.0 CATCH	0	0	0	2	2	3	6	8	0	21
18.9 MIN-MAX MEAN				9.500	9.000	17.666	0.500	5.125		6.180
19.0 CATCH	0	0	0	3	8	3	8	5	1	28
21.9 MIN-MAX MEAN				1.000	2.000	0.000	1.500	6.000	0.000	2.286
22.0 CATCH	0	0	0	0	2	0	2	4	0	8
24.9 MIN-MAX MEAN					9.500		0.000	0.000		2.375
25.0 CATCH	0	0	0	1	1	3	1	6	3	15
27.9 MIN-MAX MEAN				0.000	0.000	0.000	0.000	6.000	12.333	4.866
28.0 CATCH	0	1	0	0	2	3	1	1	0	8
29.5 MIN-MAX MEAN		0.000			0.000	1.333	39.000	0.000		5.375
10.8 CATCH	0	1	0	7	19	12	24	24	4	91
29.5 MIN-MAX MEAN		0.000		3.142	3.052	4.750	3.208	4.583	9.250	3.967
				130- 222	83- 213	117- 178	99- 230	124- 229	128- 220	83- 230
				166.7	119.0	149.0	147.8	165.1	171.5	151.6

TABLE 14 (Continued)
1969

TEMP INT. C	SALINITY INTERVAL PPT									
	16.6 16.9	17.0 19.9	20.0 22.9	23.0 25.9	26.0 28.9	29.0 31.9	32.0 34.9	35.0 37.9	38.0 39.8	39.8 39.8
10.8 CATCH	0	0	0	0	0	0	1	1	0	2
12.9 MIN-MAX							0.000	0.000		0.000
MEAN										
13.0 CATCH	1	0	0	2	1	7	6	1	0	18
15.9 MIN-MAX	0.000			0.000	0.000	1.000	0.000	0.000		0.388
MEAN						132- 178 160.8				132- 178 160.8
16.0 CATCH	0	0	1	0	0	1	7	13	2	24
18.9 MIN-MAX			0.000			45.000	1.285	1.230	0.000	2.916
MEAN						112- 194 158.5	157- 230 187.9	158- 222 188.5		112- 230 167.0
19.0 CATCH	0	1	0	3	0	0	5	6	0	15
21.9 MIN-MAX		0.000		0.000			0.000	0.000		0.000
MEAN										
22.0 CATCH	0	0	0	1	0	0	0	0	0	1
24.9 MIN-MAX				0.000						0.000
MEAN										
25.0 CATCH	0	0	0	0	0	0	0	0	0	0
27.9 MIN-MAX										
MEAN										
28.0 CATCH	0	0	0	0	0	0	0	0	0	0
29.5 MIN-MAX										
MEAN										
10.8 CATCH	1	1	1	6	1	8	19	21	2	60
29.5 MIN-MAX	0.000	0.000	0.000	0.000	0.000	6.500	0.473	0.761	0.000	1.283
MEAN						112- 194 158.7	157- 230 187.9	158- 222 188.5		112- 230 166.5

principal areas of concentrations designated as the Campeche and South Florida grounds. Osburn, Maghan and Drummond (1969) mention that this shrimp's preference for coral and shell sand bottom may be a factor in limiting its abundance in the northern Gulf, and further state that catches are principally made at night, which is in accordance with our data.

Penaeus fluviatilis Say - White Shrimp

A total of 450 white shrimp were taken during 1967-1968 only. No specimens were collected in 1969 (January through May). These individuals ranged from 56 to 195 mm in length. *Penaeus fluviatilis* was collected in all months with the greatest concentrations in May, June, December and January. This species was taken from 5 to 30 fathoms with 5 to 20 fathoms producing the greatest yields. Osburn, Maghan and Drummond (1969) found that 99% of the offshore white shrimp catch was taken in 20 fathoms or less. These authors also mention that white shrimp are occasionally taken at night, although the majority are taken during day trawling. Our samples produced the highest catch per unit of effort at night at all depths. Osburn, Maghan and Drummond

(1969) also stated that September - December produced 80% of the white shrimp catch. Our greatest catches fell in December and January. Young shrimp (under 100 mm) entered the catch in September, January and March through August. Shrimp under 70 mm were collected in January, May, July and September. The January and September recruitment of small shrimp is probably due to the emigration from Mississippi Sound caused by cooler temperatures. The influx of shrimp under 70 mm in all seasons is no doubt due to the long spawning season (spring to late fall) reported by Christmas and Gunter (1967) and others. Subrahmanyam (1971) reported that species of this genus probably spawn throughout the year in Gulf waters.

Penaeus fluviatilis was taken at temperatures and salinities ranging from 13.0° to 28.9°C and 24.6 to 39.8 ppt respectively. The greatest numbers were caught in salinities ranging from 26.0 to 31.9 ppt (Table 15).

Penaeus fluviatilis is a very large component of the shrimp fishery of this area. In 1963, 1,018,000 pounds of white shrimp were harvested from the offshore areas of Mississippi and southeastern Louisiana (Christmas and Gunter 1967).

Sicyonia brevirostris (Stimpson) - Rock shrimp

Fifty-seven specimens were taken at temperatures between 17.1° and 27.3°C and at salinities between 27.8 and 34.6 ppt. They were caught at depths of 10 to 50 fathoms with the largest number being taken at a depth of 10 fathoms. Total lengths ranged from 44 to 106 mm. This species and *Sicyonia dorsalis* were taken at the same depths, and occasionally occurred together.

Sicyonia dorsalis (Kingsley)

There were 345 specimens taken at temperature and salinity ranges of 15.1° to 26.5°C and 24.6 to 38.7 ppt respectively. Individuals were recorded at depths of 5 to 40 fathoms with the majority being found between 20 and 40 fathoms. Hildebrand (1954) found *Sicyonia dorsalis* to be most abundant in depths of 15 to 25 fathoms.

Solenocera vioscai Burkenroad

A catch of 20 specimens was recorded at temperatures between 18.5° and 19.3°C and salinities between 25.2 and 27.9 ppt. These were found only at 50 fathoms. Individuals ranged in size from 79 to 80 mm. Burkenroad (1939) found *S. vioscai* in Louisiana in depths from 20 to 100 fathoms. Hildebrand (1954) noted the species to be most common from 31 to 37 fathoms.

TABLE 15
DISTRIBUTION OF *PENAEUS FLUVIATILIS* BY BOTTOM SALINITY AND
TEMPERATURE INTERVALS SHOWING NUMBER OF SAMPLES, CATCH PER
UNIT OF EFFORT, MINIMUM, MAXIMUM AND MEAN TOTAL LENGTH (MM).
1967

TEMP INT. C	SALINITY INTERVAL PPT									
	16.0 16.9	17.0 19.9	20.0 22.9	23.0 25.9	26.0 28.9	29.0 31.9	32.0 34.9	35.0 37.9	38.0 39.8	16.6 39.8
10.8 CATCH	0	0	0	0	0	0	0	0	0	0
12.9 MIN-MAX MEAN										
13.0 CATCH	0	0	0	0	0	1	6	1	0	8
15.9 MIN-MAX MEAN						1.000 125- 125.0	1.166 105- 151.6	1.000 161- 161.0		1.125 190 150.1
16.0 CATCH	0	0	0	0	1	1	4	13	0	19
18.9 MIN-MAX MEAN					13.000 99- 152.7	3.000 189 155- 174.8	13.500 56- 195	1.538 87- 189		4.736 56- 195 140.1
19.0 CATCH	0	0	0	0	0	2	4	21	0	27
21.9 MIN-MAX MEAN						0.000	0.000	0.000		0.000
22.0 CATCH	0	0	0	0	0	1	1	12	0	14
24.9 MIN-MAX MEAN						0.000	0.000	0.083 63- 180 110.7		0.071 63- 180 110.7
25.0 CATCH	0	0	0	0	0	4	2	18	0	24
27.9 MIN-MAX MEAN						0.500 68- 75 71.5	0.000	2.611 88- 118 102.1		2.041 68- 118 100.4
28.0 CATCH	0	0	0	0	0	0	7	0	0	2
29.5 MIN-MAX MEAN							0.500 83- 83 83.0			0.500 83- 83 83.0
10.8 CATCH	0	0	0	0	1	9	19	65	0	94
29.5 MIN-MAX MEAN					13.000 99- 152.7	0.666 189 162.0	3.263 56- 195 130.5	1.061 63- 189 114.3		1.595 56- 195 130.5

1968

TEMP INT. C	SALINITY INTERVAL PPT									
	16.6 16.9	17.0 19.9	20.0 22.9	23.0 25.9	26.0 28.9	29.0 31.9	32.0 34.9	35.0 37.9	38.0 39.8	16.6 39.8
10.8 CATCH	0	0	0	0	0	0	0	0	0	0
12.9 MIN-MAX MEAN										
13.0 CATCH	0	0	0	1	4	0	6	0	0	11
15.9 MIN-MAX MEAN				0.000	1.250 96- 137 116.1		3.833 150- 250 188.1			2.545 96- 230 174.0
16.0 CATCH	0	0	0	2	2	3	6	8	0	21
18.9 MIN-MAX MEAN				9.500 130- 192 163.0	9.000 104- 153 124.9	17.666 117- 178 149.1	0.500 161- 177 171.3	5.125 127- 228 169.5		6.180 104- 328 191.9
19.0 CATCH	0	0	0	3	8	3	8	5	1	28
21.9 MIN-MAX MEAN				1.000 165- 222 206.7	2.000 178- 213 194.6	0.000	1.500 143- 207 181.9	6.000 153- 229 180.1	0.000	2.285 143- 229 183.0
22.0 CATCH	0	0	0	0	2	0	2	4	0	8
24.9 MIN-MAX MEAN					9.500 83- 130 106.0		0.000	0.000		2.375 83- 130 106.0
25.0 CATCH	0	0	0	1	1	3	1	6	3	15
27.9 MIN-MAX MEAN				0.000	0.000	0.000	0.000	6.000 124- 220 146.4	12.333 128- 220 171.5	4.866 124- 220 160.6
28.0 CATCH	0	1	0	0	2	3	1	1	0	8
29.5 MIN-MAX MEAN		0.000			0.000	1.333 121- 170 148.0	39.000 99- 170 127.0	0.000		5.375 99- 170 127.8
10.8 CATCH	0	1	0	7	19	12	24	24	4	91
29.5 MIN-MAX MEAN		0.000		3.142 130- 222 166.7	3.052 83- 213 119.0	4.750 117- 178 149.0	3.208 99- 230 147.8	4.583 124- 229 165.1	9.250 128- 220 171.5	3.967 83- 230 151.6

Solenocera sp.

Ten unidentified specimens of *Solenocera* were taken at temperatures of 18.6° to 18.9° C and salinities of 35.0 to 37.2 ppt. All were found in 50 fathoms of water.

Trachypeneus similis Smith

A total of 272 individuals of this shrimp was collected. This species was encountered in 1967-68 only and in the months of January, March, May, June and December. These individuals varied 49 to 101 mm in length and were collected in 5 to 20 fathoms with the greatest abundance occurring at 10 fathoms. The month of greatest abundance was December. Night trawling produced the highest catch per unit of effort at all stations. Temperature and salinity ranged 17.0° to 25.0° C and 24.6 to 37.2 ppt.

Subrahmanyam (1971) collected larval stages of this species in all months off Mississippi and mentioned that peak spawning activity occurred in June, July and November.

Hildebrand (1954) found this species to be quite common in his study area but uncommon at depths less than 12 fathoms. *Trachypeneus similis* is common in Mississippi Sound (GMEI data).

Trachypeneus similis contributes a small percentage of the commercial shrimp catch in Mississippi but is not usually recognized in the large quantities of brown and white shrimp (*fide* J.Y. Christmas). Eldred (1959) reported that *T. similis* and its congener *T. constrictus* contributed about 7% to the commercial catch in the Tortugas area of Florida.

SCYLLARIDAE

Scyllarides nodifer (Stimpson) - Spanish lobster

A total of five specimens appeared in the catch during 1967 and 1968. A single specimen was taken in 1967 at 40 fathoms. The specimens collected in 1968 appeared at 30 and 40 fathoms. Temperatures and salinities ranged between 19.2° and 23.0° C and 23.2 to 34.6 ppt respectively. There is a ready market for Spanish lobster as they are occasionally available in local fish markets, but no commercially exploitable stock has been located.

Scyllarus sp.

Six unidentified individuals were taken at temperatures between 17.0° and 22.0° C and at salinities between 28.8 and 36.5 ppt. They

were found at depths ranging from 30 to 50 fathoms. Specimens were deposited in the Gulf Coast Research Laboratory museum.

PORCELLANIDAE

Porcellana sayana Leach

A total of five *P. sayana* appeared in February at 30 fathoms. The temperature and salinity were 16.4°C and 35.6 ppt respectively. *Porcellana sayana* is fairly common in less than 10 fathoms around the Mississippi Sound barrier islands (fide J.Y. Christmas).

PAGURIDAE

Benthopagurus cokeri

There were ten individuals caught at temperatures between 18.6° and 20.0°C and at salinities between 35.0 and 37.8 ppt. These were found at the 50 fathom station.

Pagurus floridanus Benedict - Hermit crab

Eighteen *P. floridanus* were caught at temperatures between 13.0° and 23.1°C and at salinities between 31.2 and 35.3 ppt. Specimens were caught in 5 to 10 fathoms of water, with the majority being from the 5 fathom depth. Most of the specimens were found in gastropod shells. This hermit crab is very common in *Polinices* and *Thais* shells in Mississippi Sound.

Petrochirus bahamensis Hay and Shore

Thirty-nine specimens were caught at temperatures between 14.1° and 29.0°C and salinities between 16.6 and 37.4 ppt, between 10 and 50 fathoms. Lengths ranged from 40 to 142 mm. Hildebrand (1954) found *P. bahamensis* to be the common hermit crab on sandy bottoms in his study area. He attributed their absence on the muddy bottoms to the scarcity of gastropod shells. Williams (1965) places this species in synonymy with *P. diogenes* (Linnaeus). Most of the large specimens occupied *Busycon* shells, and more often than not, small specimens of *P. bahamensis* were found in the same shell with the large individuals.

RANINIDAE

Raninoides louisianensis Rathbun

Five *R. louisianensis* were collected during the three years of this study. Specimens were found only at 40 and 50 fathoms. Temperatures ranged between 18.3° and 20.3°C and salinities were between 24.9 and

35.4 ppt. Hildebrand (1954) found specimens only from 31 to 37 fathoms.

Raninoides sp.

An unidentified specimen was obtained in April of 1969 at Station 3 in a night haul. The temperature and salinity were 17.4°C and 34.9 ppt respectively. This specimen is in the Gulf Coast Research Laboratory museum.

DROMIIDAE

Dromidia antillensis (Stimpson)

A single specimen of *D. antillensis* was taken in 1967 at Station 1 in January. The temperature and salinity at the time of capture were 17.2°C and 26.6 ppt respectively. We have collected this species with a covering of compound ascidians in miscellaneous trawl hauls in Dog Keys Pass (between Horn and Ship Islands).

Dromidia sp.

An unidentified specimen of *Dromidia* was collected in January 1968 at a temperature of 14.8°C and a salinity of 28.5 ppt. The specimen was taken at 5 fathoms.

LEUCOSIIDAE

Persephona crinita Rathbun

Two specimens of *P. crinita* were taken in 1967, one from 10 fathoms and another from 50 fathoms. The 10-fathom specimen was taken in January with the temperature at 16.0°C and the salinity at 34.7 ppt. The 50-fathom specimen was taken in May at a temperature of 18.6°C and a salinity of 35.0 ppt. Hildebrand (1954) found ovigerous females in June.

CALAPPIDAE

Calappa springeri Rathbun

Fifth-three specimens of *C. springeri* were collected in temperatures between 14.1° and 28.0°C and in salinities between 16.6 and 38.7 ppt. They were taken in 10 to 50 fathoms. Carapace widths ranged from 67 to 134 mm. Hildebrand (1954) caught this species in almost every drag made between 12 and 25 fathoms; however, only a few were taken each drag. Hildebrand (1954) found *C. springeri* at all fishing grounds examined except the Obregon grounds off Campeche.

Hepatus epheliticus (Linnaeus) - Calico crab

Nineteen specimens were collected at depths between 5 and 50 fathoms. Temperatures ranged from 14.2° to 27.3°C and salinities ranged from 24.9 to 37.4 ppt. Carapace widths ranged from 35 to 80 mm. Only a few were captured by Hildebrand (1954) in 12 to 19 fathoms, and he remarked that this species appeared to be more abundant shoreward to 12 fathoms. Our data tend to agree with his observation.

PORTUNIDAE

Callinectes sapidus Rathbun

Only 141 blue crabs were collected during this study. This crab was obtained in all months with the exception of November and December. The depths ranged from 5 to 50 fathoms with the greatest concentration at 20 fathoms.

Sexes were always segregated in our hauls. The greatest concentration of both males and females occurred at 20 fathoms. Females were most abundant (60% of 115 recorded determinations).

We have observed large concentrations of "berried" females around the barrier islands. In the summer "berried" females were often seen swimming at the surface in the study area.

Only three specimens, all female, were taken at 50 fathoms. These measured 75 mm, 83 mm and 140 mm in carapace width.

Gunter (1950) stated that he has observed females in "berry" swimming several miles from shore, and Daugherty (1952) stated that the female moves offshore to spawn. Hildebrand (1954) found relatively few blue crabs in his study and stated that he encountered no males. Gunter (1950) and Daugherty (1952) noted the lack of males in the offshore environment.

Our specimens measured 50 to 181 mm. The temperatures and salinities of the collections ranged from 14.9° to 29.0°C and from 24.6 to 37.1 ppt respectively (Table 16).

Callinectes similis Williams - Gulf crab

Three hundred four specimens were collected. This species was obtained at Stations 1, 2, 3, 4 and 6 in all months. These individuals ranged from 39 to 171 mm in carapace width. They were most abundant at 20 fathoms. The temperatures and salinities of the collections ranged from 13.3° to 29.0°C and from 24.9 to 37.4 ppt

respectively (Table 17). There was a slight preference for salinities ranging from 29.0 to 31.9 ppt.

Approximately at midnight on 29 May 1968 in 5 fathoms of water we observed hundreds of small (approximately 40 mm carapace width) *C. similis* swimming on the surface in an apparent inshore immigration.

The spawning season of this crab must be rather long as catches of small crabs were made in January (39 mm), May (40 mm) and June (44 mm).

Callinectes similis was abundant in GMEI samples, but the largest specimen was 142 mm in carapace width. Specimens larger than 100 mm were not taken in salinities less than 15.0 ppt. *Callinectes similis* is not usually harvested in estuarine waters because of its small size. Location of concentrations of large Gulf crabs offshore could provide a new source of crab meat.

TABLE 16
DISTRIBUTION OF *CALLINECTES SAPIDUS* BY BOTTOM SALINITY AND TEMPERATURE INTERVALS SHOWING NUMBER OF SAMPLES, CATCH PER UNIT OF EFFORT, MINIMUM, MAXIMUM AND MEAN TOTAL LENGTH (MM).

		1967									
		SALINITY INTERVAL PPT									
TEMP INT. C		16.6-16.9	17.0-19.9	20.0-22.9	23.0-25.9	26.0-28.9	29.0-31.9	32.0-34.9	35.0-37.9	38.0-39.8	40.0-42.8
10.8-12.9	SMPLS. CATCH MIN-MAX MEAN	0 0 0	0 0 0	0 0 0	0 0 0	0 0 0	0 0 0	0 0 0	0 0 0	0 0 0	0 0 0
13.0-15.9	SMPLS. CATCH MIN-MAX MEAN	0 0 0	0 0 0	0 0 0	0 0 0	0 0.000	1 0.000	6 0.000	1 0.000	0 0	8 0.000
16.0-18.9	SMPLS. CATCH MIN-MAX MEAN	0 0 0	0 0 0	0 0 0	0 0.000	1 0.000	1 0.000	4 0.000	13 0.000	0 0	19 0.000
19.0-21.9	SMPLS. CATCH MIN-MAX MEAN	0 0 0	0 0 0	0 0 0	0 0	0 0.000	2 0.000	4 0.000	21 0.809	0 0	27 0.629
22.0-24.9	SMPLS. CATCH MIN-MAX MEAN	0 0 0	0 0 0	0 0 0	0 0	0 0.000	1 0.000	1 0.000	12 0.416	0 0	14 0.357
25.0-27.9	SMPLS. CATCH MIN-MAX MEAN	0 0 0	0 0 0	0 0 0	0 0	0 0.000	4 0.000	2 1.500	18 0.888	0 0	24 0.629
28.0-29.5	SMPLS. CATCH MIN-MAX MEAN	0 0 0	0 0 0	0 0 0	0 0	0 0	0 0	2 1.200	0 0	0 0	2 1.200
								154-163 158.3		154-163 158.3	
10.8-29.5	SMPLS. CATCH MIN-MAX MEAN	0 0 0	0 0 0	0 0 0	0 0	1 0.000	9 0.000	19 0.315	65 0.523	0 0	94 0.429
								84-163 129.2	50-181 84.0		50-181 86.2

NEKTONIC AND BENTHIC FAUNAS

TABLE 16 (Continued)
1968

TEMP INT. C	SALINITY INTERVAL PPT									
	16.6 16.9	17.0 19.9	20.0 22.9	23.0 25.9	26.0 28.9	29.0 31.9	32.0 34.9	35.0 37.9	38.0 39.8	16.6 39.8
10.8 12.9 CATCH MIN-MAX MEAN	0	0	0	0	0	0	0	0	0	0
13.0 15.9 CATCH MIN-MAX MEAN	0	0	0	1 0.000	4 0.000	0	6 0.000	0	0	11 0.000
16.0 18.9 CATCH MIN-MAX MEAN	0	0	0	2 4.000 65- 87 75.8	2 0.000	3 4.000 76- 100 87.0	6 0.000	8 0.000	0	21 0.952 65- 100 82.8
19.0 21.9 CATCH MIN-MAX MEAN	0	0	0	3 0.000	8 0.125 92- 92 92.0	3 0.000	8 0.500 75- 140 94.8	5 0.000	1 0.000	28 0.178 75- 140 94.3
22.0 24.9 CATCH MIN-MAX MEAN	0	0	0	0	2 0.000	0	2 0.000	4 0.000	0	8 0.000
25.0 27.9 CATCH MIN-MAX MEAN	0	0	0	1 0.000	1 0.000	3 0.333 140- 140 140.0	1 0.000	6 0.000	3 0.000	15 0.066 140- 140 140.0
28.0 29.5 CATCH MIN-MAX MEAN	0	1 0.000	0	0	2 0.000	3 4.333 65- 120 92.0	1 0.000	1 0.000	0	8 1.625 65- 120 92.0
10.8 29.5 CATCH MIN-MAX MEAN	0	1 0.000	0	7 1.142 65- 87 75.8	19 0.052 92- 92 92.0	12 2.166 65- 140 91.5	24 0.166 75- 140 94.8	24 0.000	4 0.000	91 0.428 65- 140 89.2

1969

TEMP INT. C	SALINITY INTERVAL PPT									
	16.6 16.9	17.0 19.9	20.0 22.9	23.0 25.9	26.0 28.9	29.0 31.9	32.0 34.9	35.0 37.9	38.0 39.8	16.6 39.8
10.8 12.9 CATCH MIN-MAX MEAN	0	0	0	0	0	0	1 0.000	1 0.000	0	2 0.000
13.0 15.9 CATCH MIN-MAX MEAN	1 0.000	0	0	2 0.500 92- 92 92.0	1 0.000	7 0.571 71- 87 79.2	6 0.000	1 4.000 75- 102 86.3	0	18 0.500 71- 102 84.2
16.0 18.9 CATCH MIN-MAX MEAN	0	0	1 0.000	0	0	1 3.000 75- 105 89.4	7 0.000	13 0.000	2 0.000	24 0.125 75- 105 89.4
19.0 21.9 CATCH MIN-MAX MEAN	0	1 0.000	0	3 0.000	0	0	5 0.000	6 1.000	0	15 0.066
22.0 24.9 CATCH MIN-MAX MEAN	0	0	0	1 2.000 155- 176 165.5	0	0	0	0	0	1 2.000 155- 176 165.5
25.0 27.9 CATCH MIN-MAX MEAN	0	0	0	0	0	0	0	0	0	0
28.0 29.5 CATCH MIN-MAX MEAN	0	0	0	0	0	0	0	0	0	0
10.8 29.5 CATCH MIN-MAX MEAN	1 0.000	1 0.000	1 0.000	6 0.500 92- 176 141.0	1 0.000	8 0.875 71- 105 85.7	19 0.000	21 0.238 75- 102 86.3	2 0.000	60 0.250 71- 176 94.2

TABLE 17
DISTRIBUTION OF *CALLINectes SIMILIS* BY BOTTOM SALINITY AND
TEMPERATURE INTERVALS SHOWING NUMBER OF SAMPLES, CATCH
PER UNIT OF EFFORT, MINIMUM, MAXIMUM AND MEAN TOTAL
LENGTH (MM).

		1967									
		SALINITY INTERVAL PPT									
TEMP INT. C		16.6 16.9	17.0 19.9	20.0 22.9	23.0 25.9	24.0 28.9	29.0 31.9	32.0 34.9	35.0 37.9	38.0 39.8	16.6 39.8
10.8 12.9	SHPLS. CATCH MIN-MAX MEAN	0	0	0	0	0	0	0	0	0	0
13.0 15.9	SHPLS. CATCH MIN-MAX MEAN	0	0	0	0	0	1 0.000	6 3.000 39- 92 73.3	1 0.000	0	8 2.250 92 73.3
16.0 18.9	SHPLS. CATCH MIN-MAX MEAN	0	0	0	0	1 1.000 62- 62 62.0	1 0.000	4 1.000 47- 47 47.0	13 1.769 59- 91 80.2	0	19 1.473 91 77.8
19.0 21.9	SHPLS. CATCH MIN-MAX MEAN	0	0	0	0	0	2 2.500 40- 159 67.6	4 0.750 62- 94 82.6	21 1.000 75- 100 86.9	0	27 1.074 159 80.4
22.0 24.9	SHPLS. CATCH MIN-MAX MEAN	0	0	0	0	0	1 0.000	1 0.000	12 0.000	0	14 0.000
25.0 27.9	SHPLS. CATCH MIN-MAX MEAN	0	0	0	0	0	4 2.250 69- 170 101.5	2 0.000	18 1.000 63- 113 79.4	0	24 1.125 170 87.0
28.0 29.5	SHPLS. CATCH MIN-MAX MEAN	0	0	0	0	0	0	2 0.500 87- 87 87.0	0	0	2 0.500 87 87.0
10.8 29.5	SHPLS. CATCH MIN-MAX MEAN	0	0	0	0	1 1.000 62- 62 62.0	9 1.555 40- 170 90.9	19 1.368 39- 94 73.9	65 0.953 59- 113 81.2	0	94 1.095 170 80.7
		1968									
		SALINITY INTERVAL PPT									
TEMP INT. C		16.6 16.9	17.0 19.9	20.0 22.9	23.0 25.9	24.0 28.9	29.0 31.9	32.0 34.9	35.0 37.9	38.0 39.8	16.6 39.8
10.8 12.9	SHPLS. CATCH MIN-MAX MEAN	0	0	0	0	0	0	0	0	0	0
13.0 15.9	SHPLS. CATCH MIN-MAX MEAN	0	0	0	1 1.000 63- 63 63.0	4 0.250	0	6 0.000	0	0	11 0.181 63- 63 63.0
16.0 18.9	SHPLS. CATCH MIN-MAX MEAN	0	0	0	2 2.000 75- 90 83.1	2 0.500	3 3.000 51- 94 78.6	6 0.833 66- 86 78.3	8 1.375 73- 109 86.5	0	21 1.428 109 83.0
19.0 21.9	SHPLS. CATCH MIN-MAX MEAN	0	0	0	3 0.000	8 0.000	3 1.000 74- 88 81.2	8 3.000 58- 95 73.6	5 0.400 109- 109 109.0	1 0.000	28 1.035 109 75.4
22.0 24.9	SHPLS. CATCH MIN-MAX MEAN	0	0	0	0	2 0.500 49- 49 49.0	0	2 0.000	4 0.250 81- 81 81.0	0	8 0.250 81 65.0
25.0 27.9	SHPLS. CATCH MIN-MAX MEAN	0	0	0	1 0.000	1 0.000	3 7.000 50- 126 82.3	1 1.000 75- 87 79.3	6 1.000 72- 111 89.6	3 0.000	15 1.866 126 83.8
28.0 29.5	SHPLS. CATCH MIN-MAX MEAN	0	1 0.000	0	0	2 1.000 61- 90 74.4	3 2.666 92- 104 98.7	1 0.000	1 11.000 58- 120 91.5	0	8 2.625 120 90.5
10.8 29.5	SHPLS. CATCH MIN-MAX MEAN	0	1 0.000	0	7 0.714 63- 90 80.6	19 0.263 49- 90 70.1	12 3.416 50- 126 84.6	24 1.250 58- 95 74.7	24 1.291 58- 120 89.4	4 0.000	91 1.230 126 82.3

TABLE 17 (Continued)
1969

TEMP INT. C	SALINITY INTERVAL PPT									
	16.6 16.9	17.0 19.9	20.0 22.9	23.0 25.9	26.0 28.9	29.0 31.9	32.0 34.9	35.0 37.9	38.0 39.8	16.6 39.8
SMPLS. 10.8 CATCH 12.9 MIN-MAX MEAN	0	0	0	0	0	0	1 0.000	1 0.000	0	2 0.000
SMPLS. 13.0 CATCH 15.9 MIN-MAX MEAN	1 0.000	0	0	2 0.000	1 0.000	7 1.142 71- 94 82.3	6 0.000	1 0.000	0	18 0.444 71- 94 82.3
SMPLS. 16.0 CATCH 18.9 MIN-MAX MEAN	0	0	1 0.000	0	0	1 0.000	7 0.428 72- 85 76.7	13 0.000	2 0.000	24 0.125 72- 85 76.7
SMPLS. 19.0 CATCH 21.9 MIN-MAX MEAN	0	1 0.000	0	3 0.000	0	0	5 1.200 79- 171 108.2	6 0.500 69- 72 70.5	0	15 0.600 69- 171 97.4
SMPLS. 22.0 CATCH 24.9 MIN-MAX MEAN	0	0	0	1 1.000 101- 101 101.0	0	0	0	0	0	1 1.000 101- 101 101.0
SMPLS. 25.0 CATCH 27.9 MIN-MAX MEAN	0	0	0	0	0	0	0	0	0	0
SMPLS. 28.0 CATCH 29.5 MIN-MAX MEAN	0	0	0	0	0	0	0	0	0	0
SMPLS. 10.8 CATCH 29.5 MIN-MAX MEAN	1 0.000	1 0.000	1 0.000	6 0.166 101- 101 101.0	1 0.000	8 1.000 71- 94 82.3	19 0.473 72- 171 94.2	21 0.142 69- 72 70.5	2 0.000	60 0.350 69- 171 87.1

Ovalipes ocellatus (Herbst)

Three specimens of *O. ocellatus* were taken in 1968. The temperature and salinity ranges were 19.2° to 21.0°C and 23.2 to 28.8 ppt respectively. Due to mutilation only one of the three specimens was measured (carapace width 45 mm). The depth ranged from 10 to 50 fathoms. Gunter (1950) recorded four specimens among twenty-one trawl hauls off Port Aransas, Texas at salinities of 33.6 to 36.5 ppt.

Portunus gibbesii (Stimpson)

Sixty-four of these specimens were caught at temperature and salinity ranges of 14.5° to 27.3°C and 30.4 to 37.1 ppt respectively, with a depth range of 5 to 50 fathoms. Specimens ranged in carapace width from 33 to 90 mm. This crab was taken in all months with the exception of June, October and November and was distributed almost equally across the depth range. Gunter (1950) recorded this species in lower Aransas Bay, Texas at a salinity of 19.2 ppt.

Portunus sayi (Gibbes)

There were twenty-two specimens of *P. sayi* caught between 5 and 10 fathoms within temperature and salinity ranges of 20.5° to 26.5°C and 33.6 to 38.7 ppt respectively. Carapace widths ranged from 43 to 58 mm.

Portunus spinicarpus (Stimpson)

Thirty-six specimens of this species were caught in a depth range of 30 to 50 fathoms. They were taken from temperatures between 16.6° and 27.3°C and from salinities between 23.2 and 36.5 ppt. Carapace widths ranged from 32 to 70 mm. Hildebrand (1954) found this crab most abundant between 31 and 37 fathoms.

GONEPLACIDAE

Chasmocarcinus mississippiensis - Rathbun

A single specimen was collected in February of 1969 from 50 fathoms at a temperature of 16.0°C and a salinity of 34.8 ppt. This specimen was deposited in the Gulf Coast Research Laboratory museum.

MAJIDAE

Anasimus latus Rathbun

There were 101 specimens of this crab caught at temperatures between 14.5° and 26.5°C and at salinities between 26.6 and 37.4 ppt. The depth range was 40 to 50 fathoms. Hildebrand (1954) caught a single specimen (an ovigerous female) in 19 fathoms off the Obregon fishing grounds. Ovigerous females were not found in our samples.

The type locality of *A. latus* is very close to our Station 6 (Williams 1965).

Libinia emarginata (Leach) - Spider crab

Ten specimens were taken at temperatures between 14.2° and 25.2°C and at salinities between 24.9 and 37.2 ppt. Specimens were caught at Stations 1, 2, 4 and 6. Hildebrand (1954) noted this to be the most common large spider crab in his investigation, and it was taken from depths of 6 to 24 fathoms. He encountered ovigerous females in July and February (25 to 26 fathoms for the February specimen). Gunter (1950) took specimens in lower Aransas Bay, Texas at a temperature of 9.9°C and a salinity of 17.6 ppt.

Stenocionops spinimana (Rathbun)

Forty of these crabs were caught at temperatures between 15.3° and 25.2°C and at salinities between 23.2 and 37.4 ppt. They were found at depths of 20 to 50 fathoms.

Stenorynchus seticornis (Herbst) - Arrow crab

Eleven arrow crabs were caught at temperatures between 17.8° and 25.1°C and salinities between 31.5 and 37.8 ppt. They were collected in 50 fathoms of water. A May specimen measured 35 mm.

ECHINODERMATA

ASTEROIDEA

ASTROPECTINIDAE

Astropecten duplicatus Gray

Fourteen specimens were caught at depths of 20 to 50 fathoms. They occurred at temperatures between 15.2° and 20.3°C and at salinities between 23.8 and 36.5 ppt.

Astropecten sp.

Four unidentified specimens of *Astropecten* were caught in 1967 at temperatures and salinities ranging from 19.0° to 20.5°C and 36.2 to 36.4 ppt respectively. They were taken at depths of 40 to 50 fathoms.

LUIDIIDAE

Luidia clathrata (Say)

There were 330 individuals caught in temperatures between 13.0° and 29.5°C and in salinities between 26.2 and 39.8 ppt. The majority of specimens were caught in 5 to 10 fathoms, with only one being caught at 50 fathoms in 1968. Hildebrand (1954) noted that a few specimens were found in Texas at 12 to 18 fathoms, and two were from 19 fathoms at the Obregon fishing grounds off Campeche. *Luidia clathrata* is the only starfish commonly found in Mississippi Sound (GMEI data).

ECHINASTERIDAE

Echinaster modestus

There were three specimens found in temperatures ranging from 18.3° to 21.9°C and in salinities ranging from 33.2 to 35.5 ppt. Depths of capture ranged from 40 to 50 fathoms.

ECHINOIDEA

CLYPEASTERIDAE

Clypeaster sp.

Three unidentified specimens of *Clypeaster* were found in temperatures and salinities ranging from 16.4° to 18.6°C and 36.5 to 36.9 ppt respectively. All specimens were taken at 30 fathoms. They have been deposited in the Laboratory museum.

HOLOTHUROIDEA

MOLPADIIDAE

Molpadia cubana Deichmann

A total of seven specimens appeared in 1967 and 1968 with none being taken in the 1969 hauls. The six 1967 specimens were collected at 20 fathoms during January, February and May. These specimens were taken from temperatures between 15.6° and 20.3° C and from salinities between 32.7 and 36.8 ppt. A single specimen taken in June of 1968 was found at a temperature of 25.0°C and a salinity of 37.0 ppt. Hildebrand (1954) noted the presence of *M. cubana* near shell bottoms in deeper offshore waters.

Systematic Account - Fishes

A total of 129 species (93,563 specimens) representing 103 genera and 57 families was collected. Species density and contribution to the total trawl fish catch of each family encountered are presented in Table 18. Those families considered to be of commercial importance and their contribution to the catch are shown in Table 19. Families Sciaenidae, Sparidae and Stromateidae were represented by the greatest numbers and comprised 83% of the total catch.

TABLE 18
CONTRIBUTION OF EACH FAMILY TO TOTAL CATCH OF FISHES

Family	No. of Species	Total No. Specimens	Family	No. of Species	Total No. Specimens
Garcharhinidae	2	8	Scianidae	9	42,152
Sphyrnidae	1	20	Mullidae	1	162
Squatidae	1	17	Sparidae	4	28,608
Rhinobatidae	1	1	Ephippidae	1	69
Torpedinidae	1	9	Trichiuridae	1	172
Rajiidae	2	41	Scombridae	2	65
Dasyatidae	2	12	Gobiidae	1	16
Clupeidae	4	326	Scorpaenidae	3	213
Engraulidae	2	3,736	Triglidae	11	1,118
Synodontidae	3	1,425	Uranoscopidae	3	14
Ariidae	2	557	Brotulidae	1	14
Anguillidae	1	6	Ophidiidae	2	307
Muraenidae	1	78	Stromateidae	2	7,058
Congridae	2	15	Sphyaenidae	1	8
Ophichthidae	1	1	Mugilidae	1	1
Bregmacerotidae	1	2	Polynemidae	1	1
Gadidae	3	271	Bothidae	13	1,441
Macrouridae	1	63	Soleidae	2	118
Syngnathidae	2	10	Cynoglossidae	2	66
Zeidae	1	1	Echeneidae	1	3
Serranidae	6	1,779	Balistidae	3	82
Lutjanidae	2	169	Ostraciidae	1	21
Priacanthidae	1	4	Tetradontidae	2	70
Branchiostegidae	1	11	Diodontidae	1	8
Pomatomidae	1	3	Batrachoididae	1	104
Rachycentridae	1	1	Lophidae	1	1
Carangidae	5	2,573	Antennariidae	1	49
Gerridae	1	25	Ogcocephalidae	4	396
Pomadasyidae	1	62	TOTALS	129	93,563

TABLE 19
COMPOSITION BY COMMERCIALY IMPORTANT FAMILIES OF FISHES

FAMILY	% of Total Catch
Sciaenidae	45.05
Sparidae	30.58
Stromateidae	7.54
Engraulidae	3.99
Serranidae	1.90
Bothidae	1.54
Triglidae	1.19
Ariidae	.60
Clupeidae	.35
Lutjanidae	.18
Trichiuridae	.18
Scombridae	.07
Total	93.17

Annotated List of Species

CHONDRICHTHYES

SQUALIFORMES

CARCHARHINIDAE - Requiem Sharks

Mustelus canis (Mitchill) - Smooth dogfish

The smooth dogfish was taken in both 1967 (three specimens) and in 1968 (one specimen). In March of 1967 a 963-mm TL (3.178 kg) specimen was taken at Station 1 and in June of the same year, two other specimens, 690 mm TL (1.814 kg) and 825 mm TL (2.268 kg), were collected at 50 fathoms. The March specimen was taken at 20.6°C and 30.3 ppt while 20.9°C and 37.8 ppt were recorded for the June specimens. In March of 1968 at Station 6, a 974-mm TL specimen weighing 4.327 kg was captured at a temperature of 15.3°C and a salinity of 34.6 ppt.

Scoliodon terraenovae Richardson - Atlantic sharpnose shark

The sharpnose shark first appeared in the catch in August of 1967 at 50 fathoms. The specimen measured 633 mm TL and weighed .986 kg. A temperature and salinity of 25.1°C and 36.8 ppt were recorded on this occasion. In 1968 three additional specimens were captured, one (959 mm TL and 3.901 kilograms from 20 fathoms) in January and two (550 and 688 mm TL with no weights recorded) in October. The 1968 specimens were collected at temperatures between 18.4° and 24.8°C and salinities between 30.5 and 35.7 ppt. We have taken some small *S. terraenovae* in miscellaneous trawl hauls in Mississippi Sound.

SPHYRNIDAE - Hammerhead sharks

Sphyrna tiburo (Linnaeus) - Bonnethead

Twenty bonnethead sharks were taken in three years. These sharks ranged in size from 390 to 930 mm TL and were taken at temperatures and salinities ranging between 14.6° and 26.1°C and 25.8 to 37.4 ppt. Gunter (1945) found the salinity limits to be 22.8 to 36.2 ppt. Clark and von Schmidt (1965) remarked that *S. tiburo* may have a continuous mating season during the spring and fall. Hoese and Moore (1958) noted that individuals they collected in late August ranging from 342 to 369 mm were recently born. Gunter (1945) took specimens 308 to 315 mm in September and October. The smallest bonnethead (390 mm TL) in our samples was caught in December.

Specimens collected in March were from 400 to 433 mm TL. Specimens collected in June and July at GMEI stations in Mississippi Sound were 383 to 400 mm TL. Our GMEI September and November collections ranged from 416 to 695 mm TL with the smallest specimen in November.

SQUATINIDAE - Angel sharks

Squatina dumerili Le Sueur - Atlantic angel shark

Seventeen angel sharks ranging in size from 227 to 1,003 mm TL were taken during the 3 years. Temperatures ranged between 15.3° to 20.0°C and salinities ranged between 33.5 to 37.8 ppt. The greatest catch occurred in the month of March with fourteen specimens being captured. The area of greatest concentration was at 40 fathoms.

The largest specimen, collected at Station 6 in February 1969, aborted 10 young on deck, and these were successfully returned to the laboratory alive. Since they were premature each had a large yolk sac. Sizes of young ranged from 215 to 238 mm TL.

Additional Observations - Squaliformes

A large number of sharks were observed and taken incidentally to the regular collection program. These species taken only by handline and identified were *Aprionodon isodon* (Müller and Henle); *Carcharhinus limbatus* (Müller and Henle); *Carcharhinus falciformes* (Müller and Henle); *Negaprion brevirostris* (Poey) and *Sphyrna zygaena* (Linnaeus). Among this group of sharks *Carcharhinus limbatus* was the most abundant. At our offshore stations sharks were observed in greatest numbers from March through November, with the majority occurring at the deeper stations (30 to 50 fathoms). We have utilized small bonnethead and other sharks for food. There is an abundant, unexploited population of sharks in the northern Gulf.

RAJIFORMES

RHINOBATIDAE - Guitar fishes

Rhinobatos lentiginosus (Garman) - Atlantic guitarfish

A single specimen of *R. lentiginosus* was collected at Station 1 in September 1967. A temperature and salinity of 26.1°C and 30.4 ppt respectively, were recorded at this time. The specimen measured 419 mm in length and was 107.3 grams in weight.

TORPEDINIDAE - Electric rays

Narcine brasiliensis (Olfers) - Lesser electric ray.

Nine specimens ranging in size from 245 to 395 mm TL were taken. Seven occurred in 1967 at temperatures ranging between 17.0° to 17.2°C. Salinities were recorded as being between 26.6 and 32.4 ppt. The remaining two electric rays were collected in 1968 at temperatures and salinities between 21.8° to 24.0°C and 31.8 to 33.6 ppt respectively. Gunter's (1945) limits for the same factors were 15.4° to 29.5°C and 30.6 to 36.5 ppt. This species appeared in greatest numbers (eight) at 5 fathoms. We have taken numerous *N. brasiliensis* in miscellaneous hauls around the barrier islands and in the shallow passes.

RAJIDAE - Skates

Raja eglanteria Bosc - Clearnose skate

Twelve *R. eglanteria*, 220 to 573 mm TL, were encountered. Temperatures ranged between 16.9° and 29.0°C, with salinities ranging between 26.6 and 37.2 ppt. Four were collected in 1967, six in 1968 and two in 1969. Specimens were found at all stations.

Raja texana Chandler - Texas skate

This species of *Raja* was taken in slightly greater abundance than *R. eglanteria*. Twenty-nine specimens ranging in length from 205 to 573 mm TL were taken at salinities from 27.0 to 39.8 ppt and temperatures from 13.5° to 27.3°C. Gunter's (1945) temperature limits were 13.7° to 25.5°C. Hildebrand (1954) reported *R. texana* to be present in the shallow Gulf all year long. The present specimens were taken in greater numbers at deeper offshore stations. We have taken a few *R. texana* in miscellaneous Mississippi Sound hauls.

DASYATIDAE - Stingrays

Dasyatis americana Hildebrand and Schroeder - Southern stingray

Two *D. americana* were collected during the study. A 341-mm TL specimen weighing 1,193 kilograms was taken in September 1967 at Station 1. The temperature was 26.1°C, and the salinity was 30.4 ppt. The second specimen appeared in the net at Station 5 in February 1969. The temperature and salinity were 16.9°C and 33.5 ppt. This ray measured 1,925 mm TL and weighed 37.65 kilograms.

Although only six small southern stingrays were collected in GMEI samples, we have observed many larger specimens during the summer in shallow water on sandy bottom around the barrier islands. These data

conform to the statement of Gunter (1945, p. 22) - "so far as available information goes it is present in water of high salinity and inhabits the open Gulf or the parts of the bays near the passes."

Dasyatis say (Le Sueur) - Bluntnose stingray

Ten *D. say* were collected at Station 2 during the study. In March 1967 one specimen was taken at a temperature of 14.6°C and a salinity of 35.4 ppt. A single ray taken in November 1968 occurred at a temperature of 25.2°C and a salinity of 36.5 ppt. This specimen measured 1,169 mm TL. The remaining eight rays were taken in 1969 at temperatures and salinities ranging from 13.5° to 14.9°C and 31.2 to 31.5 ppt, respectively. These eight individuals ranged in size from 260 to 1,162 mm TL.

Additional Observations - RAJIFORMES

In early September 1968 at the 5-fathom station a single *Manta birostris* (Walbaum) was observed near the boat. The manta measured approximately 8 feet across the disc. This species has been uncommonly reported in offshore surveys.

Manta rays were a common sight in the study area before World War II (vide J.Y. Christmas). Fishermen searched for rays resting at the surface because lemonfish (cobia - *Rachycentron canadum*) were nearly always found in their shade. A boat, approaching carefully, could get within casting distance. Occasionally several lemonfish could be hooked before the ray sounded.

In the intervening years, indiscriminate spearing and shooting have so reduced the population that the manta ray is a rare sight off Mississippi.

OSTEICHTHYES

CLUPEIFORMES

CLUPEIDAE - Herrings

Brevoortia patronus - Gulf menhaden

Few menhaden were taken in trawl samples. Gunter (1958) reported the failure of trawls to sample menhaden in Mississippi waters. Roithmayr's (1965) work on the composition of the commercial bottomfish fishery shows that few menhaden are taken by the trawl fishery. The total catch in our samples comprised four specimens, all taken at Station 1.

In December 1967 a 200-mm TL specimen weighing 99.2 grams was taken at a temperature of 17.2°C and a salinity of 26.6 ppt. A november 1968 specimen measuring 180 mm TL and weighing 141.3 grams appeared at a temperature and salinity of 16.4°C and 36.5 ppt. In January 1969 two menhaden (132 and 162 mm TL, 22.5 and 55.2 grams, respectively) were taken at a temperature of 14.1°C and a salinity of 32.1 ppt.

GMEI data show that menhaden are in the estuarine area all year. Over 95% of the 62,802 specimens collected (April 1968 through March 1969) in one year were taken in seines. Christmas, Gunter and Whatley (1960) described the estuarine nature of the Mississippi menhaden fishery. Combs (1969) showed that *B. patronus* spawns in Gulf waters from October through March. Christmas (unpublished data) took menhaden in the offshore study area with gill nets at the 20-fathom curve. The Gulf menhaden is present in vast numbers and with the Atlantic species supports the largest fishery in North America.

New record catches have been taken in the menhaden fishery in recent years. They must have been abundant at offshore stations during this study but they avoided the trawls.

Etrumeus sadina (Mitchill) - Atlantic round herring

Temperatures and salinities ranged from 19.6° to 27.3°C and 27.0 to 35.7 ppt for the fifty-three specimens collected. Round herring were found only at 10 and 20 fathoms. They were found in May and July 1968 and in April and May 1969. A size range of 70 to 135 mm TL was recorded.

Harengula pensacolae Goode and Bean - Gulf sardine

A temperature range between 12.0° and 29.5°C and a salinity range between 19.9 and 37.5 ppt were recorded for 266 specimens acquired in all three years. Specimens ranged from 80 to 167 mm TL, and a total weight of 4,734 kilograms was noted.

Specimens were found no deeper than 10 fathoms. Gunter (1945) and Reid (1954) noted the disappearance of *H. pensacolae* from inshore waters from December through early spring. Our offshore catches increased from late winter through early spring.

The Gulf sardines were taken in GMEI samples in all months but were relatively rare from November through April. About 90% of the 2,416 specimens collected in 1968-69 were young of the year caught at seine stations.

Opisthonema oglinum (Le Sueur) - Atlantic thread herring

Atlantic thread herring, like menhaden were rarely caught in our trawl samples. Three Atlantic thread herring were collected. A single 142-mm TL specimen weighing 35.0 grams was taken in January 1968 at Station 1. The temperature and salinity at this time was 14.8°C and 28.5 ppt. In April 1969 two specimens, 113 and 135 mm TL, and weighing 13.5 and 22.4 grams, were collected at Stations 1 and 2, respectively. The temperature and salinity extremes were 19.6°C and 35.7 ppt. Miles and Simmons (1950) and Christmas, Gunter and Whatley (1960) mention that the thread herring makes up only a small percentage of the menhaden catch.

Fuss, Kelley and Prest (1969) suggested a spawning season from March through August with noticeable peaks in June for the Fort Myers, Florida, area. A spawning period during May and June has been established by Hildebrand (1963) for the Beaufort, North Carolina area.

Bullis and Thompson (1967) estimated that the thread herring stocks in the Gulf of Mexico amount to 1 million tons. They showed that this species is in the northern Gulf throughout the year. This species was not taken in GMEI samples.

A thread herring fishery started operations at Charlotte Harbor in 1967 (Fuss et al. 1969) but this resource is not exploited in the northern Gulf. Mississippi menhaden fishermen (*vide* J. Y. Christmas) prefer not to catch thread herring when menhaden are available, because the oil yield is low.

ENGRAULIDAE - Anchovies

Anchoa hepsetus (Linnaeus) - Striped anchovy

A total of 2,052 striped anchovies were collected. They were taken during all months and at all depths ranging 5 to 50 fathoms; however, the majority were taken only out to 20 fathoms. The 5- and 10-fathom stations yielded the greatest catch. At all stations in all three years, day sampling produced the largest catch by far. The sizes of specimens ranged from 72 to 156 mm TL. The temperatures and salinities of collections ranged from 13.0° to 29.0°C, and 25.7 to 37.4 ppt respectively. In all three years, the month of April yielded the highest catch per unit effort and also the largest specimens were taken in this month. Hildebrand and Cable (1930) reported the striped anchovy reaches maturity at approximately 75 mm. If this is correct we collected only mature specimens. They also indicated that spawning occurs between April and July both inshore and offshore in the Beaufort, North Carolina area. Gunter (1945) found ripe individuals in the Gulf in May, and Springer and Woodburn (1960) took ripe or

nearly ripe adults from March through May and young individuals in July and December in Tampa Bay area of Florida. Since a spring spawning period is indicated by these workers the large catches in April, May and June are probably indicative of the spawning component in the offshore Mississippi area.

Gunter (1945) reported an almost total absence of this species from the bays of Texas during colder months. Our larger catches in October and November indicate a migration to warmer deeper waters in the study area. Gunter (1945) reported taking this species at a salinity of 2.5 ppt and Simmons (1957) took this fish at salinities up to 85 ppt. Gunter and Hall (1965) reported this species from as low as 1.8 ppt in south Florida. The majority of our specimens seemed to prefer salinities ranging from 29.0 to 37.9 ppt. (Table 20).

The approximate total mass was 27.84 kg. Larger catches of this species would probably have been recorded had trawls with a smaller mesh size been employed.

GMEI samples often included *A. hepsetus* from May through October. A few were collected in April and November. One December sample included *A. hepsetus*. They apparently were not in estuarine waters from January through March.

The total length range in the estuarine study area was 9 to 160 mm. Young striped anchovies appeared in seine hauls from April through July, indicating a spring spawning season with utilization of the estuarine nursery area.

There are no good estimates of the total striped anchovy stocks in the Gulf; we believe however, that this species would support a fishery. Gunter (1938a and 1941) estimated this to be one of the most abundant species in the shallow Gulf. This resource is harvested only incidentally in the industrial bottomfish fishery. Both fishing and processing methods will require development before these anchovies can be profitably exploited in Gulf waters.

Anchoa mitchilli (Valenciennes) - Bay anchovy

The bay anchovy (1,684 specimens) appeared only in January, February, April and August. Gunter (1945) stated that apparently *A. mitchilli* is most common in the Gulf during winter and spring while being somewhat scarce in the summer months. Our data tends to agree since, as stated previously, the fish was taken during colder months and virtually disappeared in the summer.

Specimens ranged from 44 to 90 mm TL, and were taken at temperatures and salinities from 13.0° to 29.0°C and 28.5 to 33.8 ppt.

TABLE 20
DISTRIBUTION OF *ANCHOA HEPSETUS* BY BOTTOM SALINITY AND
TEMPERATURE INTERVALS SHOWING NUMBER OF SAMPLES, CATCH PER
UNIT OF EFFORT, MINIMUM, MAXIMUM AND MEAN TOTAL LENGTH (MM).

1967

TEMP INT. C	SALINITY INTERVAL PPT									
	16.6 16.9	17.0 19.9	20.0 22.9	23.0 25.9	26.0 28.9	29.0 31.9	32.0 34.9	35.0 37.9	38.0 39.8	16.6 39.8
10.8 CATCH	0	0	0	0	0	0	0	0	0	0
12.9 MIN-MAX MEAN										
13.0 CATCH	0	0	0	0	0	1	6	1	0	8
15.9 MIN-MAX MEAN						3.000 98- 130 114.3	1.666 106- 125 112.6	0.000	0	1.625 98- 130 113.0
16.0 CATCH	0	0	0	0	1	1	4	13	0	19
18.9 MIN-MAX MEAN					2.000 97- 119 108.0	9.000 105- 128 116.4	0.250 116- 116 116.0	23.769 103- 153 116.6	0	16.894 97- 153 116.5
19.0 CATCH	0	0	0	0	0	2	4	21	0	27
21.9 MIN-MAX MEAN						8.500 107- 133 117.1	18.500 102- 137 116.6	0.047 135- 135 135.0	0	3.407 102- 137 116.9
22.0 CATCH	0	0	0	0	0	1	1	12	0	14
24.9 MIN-MAX MEAN						62.000 100- 133 113.3	3.000 118- 118 118.0	0.083 129- 129 129.0	0	4.714 100- 133 113.7
25.0 CATCH	0	0	0	0	0	4	2	18	0	24
27.9 MIN-MAX MEAN						0.750 124- 136 131.3	4.500 112- 125 117.4	0.555 87- 125 97.9	0	0.916 87- 136 110.4
28.0 CATCH	0	0	0	0	0	0	2	0	0	2
29.5 MIN-MAX MEAN							0.000	0	0	0.000
10.8 CATCH	0	0	0	0	1	0	19	65	0	94
29.5 MIN-MAX MEAN					2.000 97- 119 108.0	10.444 98- 136 114.9	5.105 102- 137 116.3	4.938 87- 153 115.3	0	5.468 87- 153 115.4

1968

TEMP INT. C	SALINITY INTERVAL PPT									
	16.6 16.9	17.0 19.9	20.0 22.9	23.0 25.9	26.0 28.9	29.0 31.9	32.0 34.9	35.0 37.9	38.0 39.8	16.6 39.8
10.8 CATCH	0	0	0	0	0	0	0	0	0	0
12.9 MIN-MAX MEAN										
13.0 CATCH	0	0	0	1	4	0	6	0	0	11
19.9 MIN-MAX MEAN				20.000 94- 126 111.1	12.750 72- 139 117.1		4.666 98- 139 114.8		0	9.000 72- 139 112.6
16.0 CATCH	0	0	0	2	2	3	6	8	0	21
18.9 MIN-MAX MEAN				0.000 105- 135 115.3	12.000 105- 135 115.3	0.000	0.000	83.500 90- 140 114.4	0	32.952 90- 140 114.6
19.0 CATCH	0	0	0	3	8	3	8	5	1	28
21.9 MIN-MAX MEAN				0.000 0.000	0.000	0.000	36.750 105- 156 127.0	0.000	0.000	10.500 105- 156 127.0
22.0 CATCH	0	0	0	0	2	0	2	4	0	8
24.9 MIN-MAX MEAN					54.000 110- 137 123.0		27.000 111- 140 121.9	9.500 103- 139 115.2	0	29.000 103- 140 121.1
25.0 CATCH	0	0	0	1	1	3	1	6	3	15
27.9 MIN-MAX MEAN				0.000 19.000 93- 119 104.3	19.000 110- 142 122.6	27.333	0.000	0.166 148- 148 148.0	0.000	6.800 93- 148 119.4
28.0 CATCH	0	1	0	0	2	3	1	1	0	8
29.5 MIN-MAX MEAN		0.000			5.000 80- 104 86.7	21.000 107- 138 125.3	17.000 80- 106 87.1	0.000	0	11.250 80- 138 113.8
10.8 CATCH	0	1	0	7	19	12	24	24	4	91
29.5 MIN-MAX MEAN		0.000		2.857 94- 126 111.1	11.157 72- 139 115.8	12.083 107- 142 123.8	16.375 80- 156 120.6	29.458 90- 148 114.8	0.000	16.230 72- 156 116.4

TABLE 20 (Continued)
1969

TEMP INT. C	SALINITY INTERVAL PPT									
	16.6 16.9	17.0 19.9	20.0 22.9	23.0 25.9	26.0 28.9	29.0 31.9	32.0 34.9	35.0 37.9	36.0 39.8	16.6 39.8
10.8 CATCH	0	0	0	0	0	0	1	1	0	2
12.9 MIN-MAX MEAN							0.000	0.000		0.000
13.0 CATCH	1	0	0	2	1	7	6	1	0	18
15.9 MIN-MAX MEAN	0.000			0.000	5.000 100- 114.2	1.571 132 114-	0.000	0.000		0.888 132 118.9
16.0 CATCH	0	0	1	0	0	1	7	13	2	24
18.9 MIN-MAX MEAN			0.000			0.000	0.000	0.000	0.000	0.000
19.0 CATCH	0	1	0	3	0	0	5	6	0	15
21.9 MIN-MAX MEAN	0.000			3.333 105- 119.2	141 141		5.200 104- 116.8	1.500 128 112-	143 143	3.000 104- 118.5
22.0 CATCH	0	0	0	1	0	0	0	0	0	1
24.9 MIN-MAX MEAN				0.000						0.000
25.0 CATCH	0	0	0	0	0	0	0	0	0	0
27.9 MIN-MAX MEAN										
28.0 CATCH	0	0	0	0	0	0	0	0	0	0
29.5 MIN-MAX MEAN										
10.8 CATCH	1	1	1	6	1	8	19	21	2	60
29.5 MIN-MAX MEAN	0.000	0.000	0.000	1.666 105- 119.2	5.000 141 100- 132 114-	1.375 130 104-	1.468 128 112-	0.428 143	0.000	1.016 100- 143 118.6

By far the greatest number of specimens was taken at the 5-fathom depth with only a few being found in 10 fathoms. No bay anchovies occurred beyond 10 fathoms. The mesh size of the trawl could have allowed a number of smaller bay anchovies to escape capture.

Bay anchovies were the most abundant fish in GMEI samples.

MYCTOPHIFORMES

SYNODONTIDAE - Lizardfishes

Saurida brasiliensis Norman - Largescale lizardfish

Two largescale lizardfish were taken, one in March 1967 from 50 fathoms and another in April 1969 from 20 fathoms. The March specimen measured 95 mm TL and weighed 4.3 gm, and the fish collected in April measured 133 mm TL and weighed 17.4 gm. The temperature and salinities were 20.0°C and 37.8 ppt (March) and 17.8°C and 39.8 ppt (April).

Synodus foetens (Linnaeus) - Inshore lizardfish

A total of 1,413 inshore lizardfish were collected during all months and at all stations. Although they were taken at depths ranging 5 to 50 fathoms, Stations 3 and 4 at depths of 20 and 30 fathoms respectively produced the greatest yields. These specimens ranged 99 to 478 mm TL. The temperatures ranged 12.0° to 29.5°C and the salinities 16.6 to 39.8 ppt. Our smallest specimen (99 mm TL) was taken in November; however, specimens 115 mm TL and 117 mm TL were taken in July and August, respectively. Gunter (1945) said this species probably spawns in the spring. Reid (1954) concurred, but Springer and Woodburn (1960) found very small individuals in November and December. Miller (1965) took a 93-mm specimen in March and mentioned this could be a product of fall spawning.

Hildebrand (1954) found no seasonal trends for this fish, and our catch records tend to coincide with his findings.

Smaller *S. foetens* (38 to 279 mm TL) were taken in GMEI samples.

Trachinocephalus myops (Forster) - Snakefish

Ten snakefish were taken, three in 1967 and six in 1968 (177 to 300 mm TL, size range for both years). These fish occurred at temperatures and salinities ranging 16.4° to 25.5°C and 23.2 to 37.8 ppt. A single specimen (218 mm TL) was caught in a day haul in April 1969 at a temperature of 18.4°C and a salinity of 37.4 ppt. Fish were obtained only at 30 and 40 fathoms. This species did not occur in GMEI samples.

CYPRINIFORMES

ARIIDAE - Sea catfishes

Bagre marinus (Mitchill) - Gafftopsail catfish

Five gafftopsail catfish were collected during the study, three in September 1967, one in November 1967, and one in February 1969. The specimens taken in 1967 ranged from 163 to 340 mm TL and were taken at temperatures and salinities ranging from 14.0° to 26.1°C and 31.5 to 32.4 ppt respectively. All of these fish were collected at Station 1. The February 1969 specimen was from Station 1 and measured 191 mm TL and weighed 46.0 grams. The temperature and salinity at this time were 14.0°C and 31.5 ppt. Total weight for *B. marinus* was 1.013 kilograms.

Gudger (1918) and Gunter (1945) reported the spawning period

of the gafftopsail catfish to be in May and June for a very short duration. Our catches of young fish in February (191 mm) and November (164 mm) indicate the possibility of first year fish leaving the estuary during the colder season. GMEI bay samples with one exception in February included gafftopsail from April through October only, and a large male carrying eggs with well developed embryos was taken in June 1966.

Gafftopsail catfish are marketed for the table in Mississippi. Most of the catch (20,000 pounds in 1965) has been taken incidentally in other fisheries, including the industrial bottomfish and menhaden fisheries. Christmas, Gunter and Whatley (1960) observed *B. marinus* in 52% of the menhaden hauls they sampled. Gafftops were the fifth most abundant species (2.8%) caught in the menhaden fishery. Most of the gafftops were removed by the fishermen and either eaten or sold in the food-fish market (fide J.Y. Christmas).

Galeichthys felis (Linnaeus) - Sea catfish

A total of 552 sea catfish was collected and they were taken in all months. Specimens were obtained at depths ranging from 5 to 50 fathoms but were taken in largest numbers at 5 fathoms. Gunter (1945) found few fish in winter in the Texas bays and none in January, Hildebrand (1954) noted this fish was not common offshore during the winter months and our data are in agreement. However, Miller (1965) found this species more abundant during the colder months with a sharp decline as temperatures warmed. Although an increase in numbers was expected during the colder months due to an offshore migration to escape colder temperatures, this was not in evidence. The catch increased during the warmer months with June showing the greatest catch. Our observations of the absence of this fish from the Mississippi Sound and adjacent bays during the winter months (GMEI data) coupled with the scarcity of sea catfish at depths to 50 fathoms indicate a wide winter scattering of *G. felis* from this area.

The sizes of the sea catfish taken ranged 132 to 361 mm TL. The temperatures and salinities varied 12.0° to 29.5° C and 24.9 to 37.5 ppt. The highest catch per unit of effort during the study occurred in 1967 at temperature and salinity intervals of 19.0° to 21.9° C and 29.0 to 31.9 ppt respectively (Table 21).

ANGUILLIFORMES

ANGUILLIDAE - Freshwater eels

Anguilla rostrata (Le Sueur) - American eel

The first specimen of *A. rostrata* appeared in November 1967 at a

temperature and salinity of 19.5°C and 35.4 ppt. The specimen measured 409 mm TL and weighed 70.1 g. In 1968 four eels were collected (one each from Stations 2, 3, 4 and 6) in temperature and salinity ranges of 15.2° to 22.0°C and 33.0 to 34.6 ppt respectively. These individuals ranged in length and weight from 376 to 495 mm TL and from 71.3 to 144.3 g. A single February 1969 specimen, 445 mm in TL and weighing 98.3 g, was taken from 20 fathoms at a temperature of 15.1°C and a salinity of 30.1 ppt.

Bullis and Thompson (1967) suggested that eel stocks would support a small fishery. This resource remains unexploited in Mississippi.

MURAENIDAE - Morays

Gymnothorax nigromarginatus (Girard) - Blackedged moray

This represents the only species of moray taken during the study. Seventy-eight specimens (1967 - 5, 1968 - 54, and 1969 - 19) were collected at temperatures and salinities ranging from 15.2° to 28.0°C and 19.9 to 39.8 ppt. The size range was 224 to 477 mm TL with a total mass of 9.139 kg. *Gymnothorax nigromarginatus* was collected in all months. None were taken at less than 20 fathoms.

CONGRIDAE - Conger eels

Congrina flava (Goode and Bean) - Yellow conger

The yellow conger eels (four specimens) were taken only in 1968 (January, October and November) at temperatures and salinities ranging between 15.2° and 19.3°C and from 27.9 to 37.4 ppt. These eels ranged from 197 to 414 mm TL. *Congrina flava* has rarely been reported in the northern Gulf. Roithmayr (1965) found them in industrial bottomfish catches. Specimens were taken from 20 to 50 fathoms.

Hoplunnis macrurus Ginsburg - Silver conger

A single specimen taken at 50 fathoms during June 1967 in a night haul measured 447 mm TL and was taken at a temperature and salinity of 18.3°C and 35.4 ppt. Seven fish (210 and 549 mm TL) were taken in 1968. Temperatures and salinities for these specimens ranged between 15.3° to 26.5°C and 25.2 to 38.7 ppt. Three fish (296 and 426 mm TL) taken in 1969 were found at temperatures of 16.7° to 20.5°C and salinities of 19.9 to 35.7 ppt. The 1968 and 1969 specimens were collected between 20 and 50 fathoms. Hildebrand (1954) reported this species and noted females with eggs in January and May.

TABLE 21
DISTRIBUTION OF *GALEICHTHYS FELIS* BY BOTTOM SALINITY AND
TEMPERATURE INTERVALS SHOWING NUMBER OF SAMPLES, CATCH
PER UNIT OF EFFORT, MINIMUM, MAXIMUM AND MEAN TOTAL
LENGTH (MM).

		1967									
		SALINITY INTERVAL PPT									
TEMP	INT.	16.6	17.0	20.0	23.0	26.0	29.0	37.0	35.0	38.0	16.6
C		16.9	19.9	22.9	25.9	28.9	31.9	34.9	37.9	39.8	39.8
	SMPLS.	0	0	0	0	0	0	0	0	0	0
10.8	CATCH										
12.9	MIN-MAX										
	MEAN										
	SMPLS.	0	0	0	0	0	1	6	1	0	8
13.0	CATCH						0.000	0.833	2.000		0.875
15.9	MIN-MAX							165- 325	209- 361		165- 361
	MEAN							273.2	285.0		276.5
	SMPLS.	0	0	0	0	1	1	4	13	0	19
16.0	CATCH					1.000	0.000	0.000	0.000		0.052
18.9	MIN-MAX					175- 175					175- 175
	MEAN					175.0					175.0
	SMPLS.	0	0	0	0	0	2	4	21	0	27
19.0	CATCH						130.500	4.500	0.238		10.518
21.9	MIN-MAX						169- 301	217- 334	205- 292		169- 334
	MEAN						204.9	265.6	254.6		213.9
	SMPLS.	0	0	0	0	0	1	1	12	0	14
22.0	CATCH						2.000	10.000	0.416		1.214
24.9	MIN-MAX						243- 270	155- 318	227- 265		159- 318
	MEAN						256.5	259.3	246.6		255.2
	SMPLS.	0	0	0	0	0	4	2	18	0	24
25.0	CATCH						9.250	0.500	1.500		2.708
27.9	MIN-MAX						158- 312	182- 182	183- 320		158- 320
	MEAN						214.0	182.0	253.9		230.1
	SMPLS.	0	0	0	0	0	0	2	0	0	2
28.0	CATCH							0.000			0.000
29.5	MIN-MAX										
	MEAN										
	SMPLS.	0	0	0	0	1	9	19	65	0	94
10.8	CATCH					1.000	33.333	1.789	0.600		1.978
29.5	MIN-MAX					175- 175	158- 312	155- 334	183- 361		155- 361
	MEAN					175.0	207.6	262.4	254.6		223.0

		1968									
		SALINITY INTERVAL PPT									
TEMP	INT.	16.6	17.0	20.0	23.0	26.0	29.0	32.0	35.0	38.0	16.6
C		16.9	19.9	22.9	25.9	28.9	31.9	34.9	37.9	39.8	39.8
	SMPLS.	0	0	0	0	0	0	0	0	0	0
10.8	CATCH										
12.9	MIN-MAX										
	MEAN										
	SMPLS.	0	0	0	1	4	0	6	0	0	11
13.0	CATCH				2.000	3.000		0.000			1.272
15.9	MIN-MAX				278- 305	176- 315					176- 315
	MEAN				291.5	268.3					271.6
	SMPLS.	0	0	0	2	2	3	6	8	0	21
16.0	CATCH				1.000	1.000	0.000	0.500	1.625		0.952
18.9	MIN-MAX				266- 308	283- 313		267- 285	149- 274		199- 313
	MEAN				287.0	298.0		276.6	223.3		245.2
	SMPLS.	0	0	0	3	8	3	8	5	1	28
19.0	CATCH				0.000	0.000	0.000	0.750	0.000	0.000	0.214
21.9	MIN-MAX							204- 335			204- 335
	MEAN							272.8			272.8
	SMPLS.	0	0	0	0	2	0	2	4	0	6
22.0	CATCH					0.000		5.000	1.750		2.125
24.9	MIN-MAX							231- 272	252- 313		231- 313
	MEAN							253.3	283.7		265.6
	SMPLS.	0	0	0	1	1	3	1	6	0	15
25.0	CATCH				0.000	8.000	0.666	3.000	0.000	0.000	0.866
27.9	MIN-MAX					230- 313	192- 204	249- 294			192- 313
	MEAN					281.1	198.0	270.0			265.7
	SMPLS.	0	1	0	0	2	3	1	1	0	8
28.0	CATCH		0.000			8.000	0.666	0.000	0.000		2.250
29.5	MIN-MAX					201- 279	263- 268				201- 279
	MEAN					247.0	265.5				249.1
	SMPLS.	0	1	0	7	19	12	24	24	4	91
10.8	CATCH		0.000		0.571	2.000	0.333	0.916	0.833	0.000	0.967
29.5	MIN-MAX				266- 308	176- 315	192- 268	204- 335	199- 313		176- 335
	MEAN				289.2	263.6	231.7	264.0	244.5		259.1

TABLE 21 (Continued)
1969

TEMP INT. C	SALINITY INTERVAL PPT									
	16.6 16.9	17.0 19.9	20.0 22.9	23.0 25.9	26.0 28.9	29.0 31.9	32.0 34.9	35.0 37.9	38.0 39.8	39.6 39.8
SMPLS. 10.8 CATCH	0	0	0	0	0	0	1	1	0	2
12.9 MIN-MAX							0.000	4.000		2.000
MEAN								265- 331		265- 331
								302.0		302.0
SMPLS. 13.0 CATCH	1	0	0	2	1	7	6	1	0	18
15.9 MIN-MAX	0.000			0.000	3.000	1.571	1.000	0.000		1.111
MEAN					166- 315	158- 334	168- 270			158- 334
					247.0	233.8	219.0			231.3
SMPLS. 16.0 CATCH	0	0	1	0	0	1	7	13	2	24
18.9 MIN-MAX			0.000			0.000	0.000	0.000	0.000	0.000
MEAN										
SMPLS. 19.0 CATCH	0	1	0	3	0	0	5	6	0	15
21.9 MIN-MAX		0.000		1.333			8.400	1.333		3.600
MEAN				187- 264			206- 320	200- 281		187- 320
				233.7			251.4	245.2		249.2
SMPLS. 22.0 CATCH	0	0	0	1	0	0	0	0	0	1
24.9 MIN-MAX				12.000						12.000
MEAN				132- 265						132- 265
				232.5						232.5
SMPLS. 25.0 CATCH	0	0	0	0	0	0	0	0	0	0
27.9 MIN-MAX										
MEAN										
SMPLS. 28.0 CATCH	0	0	0	0	0	0	0	0	0	0
29.5 MIN-MAX										
MEAN										
SMPLS. 10.8 CATCH	1	1	1	6	1	8	19	21	2	60
29.5 MIN-MAX	0.000	0.000	0.000	2.666	3.000	1.375	2.526	0.571	0.000	1.500
MEAN				132- 245	166- 315	158- 334	168- 320	200- 311		132- 334
				232.8	247.0	233.8	247.3	264.1		245.3

OPHICHTHIDAE

Ophichthus ocellatus (Le Sueur) - Spotted eel

A single large specimen measuring 184 cm and weighing 14.5 g was taken in March 1969 from 40 fathoms. The temperature was 16.4°C and the salinity was 35.7 ppt. This species occasionally occurs in commercial catches offshore.

GADIFORMES

BREGMACEROTIDAE

Bregmaceros atlanticus Goode and Bean - Antenna codlet

This species was represented by two specimens, both measuring 55 mm TL and weighing 0.8 g. The two fish were taken together in a March 1967 haul from 50 fathoms. The temperature and salinity were 20.0°C and 37.8 ppt.

GADIDAE - Codfishes and Hakes

Physiculus fulvus Bean

One specimen of *P. fulvus*, 104 mm TL, was collected at 50 fathoms in February 1969. The temperature was 16.0°C and the salinity was 34.8 ppt. This species of gadid is seldom listed in literature concerning the Gulf of Mexico.

Urophycis floridanus (Bean and Dresel) - Southern Hake

One hundred and ten southern hake (75 to 375 mm TL) were collected during the three years of sampling. They were found at all stations. No southern hake were caught in December and January. The temperatures and salinities ranged 13.3° to 26.5° C and 24.6 to 38.7 ppt.

Juveniles are usually inshore from January through April (Gunter 1945, Reid 1954, Moe and Martin 1965). During the present study several individuals ranging from 75 to 100 mm TL were acquired in deep offshore waters.

GMEI records show that *U. floridanus* is common in the estuarine study area from February through April. They apparently move to deeper water in the warm months. The minimum size in Mississippi Sound was 37 mm TL.

Urophycis regius (Walbaum) - Spotted Hake

The spotted hake comprised 160 specimens in our samples. This species has been rarely reported in other surveys. Specimens ranged in size from 83 to 245 mm TL. *Urophycis regius* and *U. floridanus* were occasionally taken simultaneously. Temperatures and salinities for spotted hake ranged between 13.3° to 27.0°C and 16.6 to 38.2 ppt respectively. Seasonal occurrence of spotted hake in the estuarine study area (GMEI samples) was similar to observations of southern hake.

MACROURIDAE - Grenadiers

Steindachneria argentea (Goode and Bean)

A total of 63 *S. argentea* was taken in November 1968 in the same haul at Station 3. These specimens ranged in size from 77 to 147 mm TL with the total weight being 382.0 grams. The fish were taken at a temperature of 16.4°C and a salinity of 37.4 ppt.

GASTEROSTEIFORMES

SYNGNATHIDAE - Pipefishes and seahorses

Hippocampus erectus Perry

Hippocampus erectus was taken only in 1968 on two occasions (Station 2, July - 5 specimens; Station 6, August - 3 specimens). Temperature and salinities ranged from 21.9° to 26.4°C and from 29.0 to 33.2 ppt.

Hippocampus zosterae Jordan and Gilbert - Dwarf seahorse

Two specimens of *H. zosterae* were recorded; both in 1967. A July specimen from Station 3 was taken at a temperature of 22.4°C and a salinity of 36.5 ppt. The other specimen was collected at Station 4 in August. The temperature was 25.2°C and the salinity was 36.0 ppt.

ZEIFORMES

ZEIDAE

Zenopsis ocellata (Storer) - John Dory

A single specimen of *Z. ocellata* was collected in an October 1968 haul from the 50-fathom station. The fish measured 198 mm TL and weighed 150.7 g. The temperature and salinity were 21.8°C and 26.6 ppt. *Zenopsis ocellata* has rarely been reported in the literature concerning the Gulf of Mexico.

PERCIFORMES

SERRANIDAE - Sea basses

Anthiasicus leptus Ginsburg

A single 116-mm TL specimen of *A. leptus* was taken from 50 fathoms in February 1969. A temperature and salinity of 16.0°C and 34.8 ppt were noted at this time. This species has been uncommonly reported in the literature. Hoese (1958) lists *A. leptus* as being taken in the Gulf from 150 fathoms.

Centropristes ocyurus (Jordan and Evermann) - Bank sea bass

A total of 951 bank sea bass was taken. They were encountered in all months and at depths of 5 to 50 fathoms with concentrations at 20 and 50 fathoms. These specimens measured 83 to 135 mm TL. All measurements were from snout to tip of the caudal filament. If caudal

filaments were damaged or missing, only standard lengths were taken, and these are not recorded here. The temperatures and salinities ranged from 14.0° to 29.0° C and 16.6 to 38.7 ppt respectively (Table 22).

Springer and Woodburn (1960) took this species from 6 to 10 fathoms off Tampa Bay, Florida. Roithmayr (1965) lists this fish as being taken in the industrial bottomfish catches of the north-central Gulf.

Centropristes philadelphicus (Linnaeus) Rock sea bass

A small number of rock sea bass (147) was taken in 1967 and 1969 at temperatures and salinities from 12.0° to 22.9° C and 24.9 to 37.9 ppt. This species appeared only in the first five months of each year with no specimens being taken in the remaining months. Catches were greater at the deeper stations. Gunter (1945) reported specimens in offshore Texas waters in March, May, August and September. Miller (1965) states that spawning may extend from spring through the summer. A size range of 105 to 275 mm TL was recorded for the captured specimens. Small rock sea bass (21 to 130 mm TL) were taken at GMEI stations in Mississippi Sound.

Diplectrum arcuarium Ginsburg - Sandfish

A total of 371 specimens was collected in three years. Fish were taken at temperatures and salinities between 12.0° to 28.0° C and 24.6 to 37.9 ppt respectively. Hildebrand (1954) and Miller (1965) reported this species to be most abundant between 15 and 30 fathoms. In this study specimens were taken in greater numbers from 10 to 20 fathoms. Fish range in size from 75 to 150 mm TL. We have taken numerous small sandfish from Mississippi Sound in miscellaneous trawl hauls.

Serranus atrobranchus Cuvier - Blackear bass

A total of 305 individuals of this species was taken. They were encountered at depths from 5 to 50 fathoms. The greatest numbers were taken at 20 fathoms. The size range was from 50 to 131 mm TL. The temperatures and salinities ranged 15.2° to 29.0° C and 24.6 to 38.6 ppt respectively. Fish were taken in all months with the greatest abundance being found in the cooler months of October through March.

Dawson (1966) encountered this species in 15 to 20 fathoms of water off Grand Isle, Louisiana.

Serranus notospilus Longley - Saddle bass

Four specimens of the saddle bass were taken. All were collected in a March 1967 haul from 50 fathoms and were from 72 to 93 mm TL. The temperature was 20.0° C and the salinity was 37.8 ppt.

TABLE 22
DISTRIBUTION OF *CENTROPRISTES OCYURUS* BY BOTTOM SALINITY AND TEMPERATURE INTERVALS SHOWING NUMBER OF SAMPLES, CATCH PER UNIT OF EFFORT, MINIMUM, MAXIMUM AND MEAN TOTAL LENGTH (MM).

1967

TEMP INT. C	SALINITY INTERVAL PPT									
	16.6 16.9	17.0 19.9	20.0 22.9	23.0 25.9	26.0 28.9	29.0 31.9	32.0 34.9	35.0 37.9	38.0 39.8	16.6 39.8
SMPLS. 10.8 CATCH	0	0	0	0	0	0	0	0	0	0
12.9 MIN-MAX MEAN										
SMPLS. 13.0 CATCH	0	0	0	0	0	1	6	1	0	8
15.9 MIN-MAX MEAN						0.000	0.000	0.000		0.000
SMPLS. 16.0 CATCH	0	0	0	0	1	1	4	13	0	19
18.9 MIN-MAX MEAN					0.000	2.000	0.000	10.846 112- 293 175.5		7.526 112- 315 175.5
SMPLS. 19.0 CATCH	0	0	0	0	0	2	4	21	0	27
21.9 MIN-MAX MEAN						0.000	0.000	3.666 112- 315 207.0		2.851 112- 315 207.0
SMPLS. 22.0 CATCH	0	0	0	0	0	1	1	12	0	14
24.9 MIN-MAX MEAN						0.000	0.000	7.666 120- 285 159.9		6.571 120- 285 159.9
SMPLS. 25.0 CATCH	0	0	0	0	0	4	2	18	0	24
27.9 MIN-MAX MEAN						0.250	3.000	3.666 83- 87 85.0		3.041 83- 87 85.0
SMPLS. 28.0 CATCH	0	0	0	0	0	0	2	0	0	2
29.5 MIN-MAX MEAN							0.000			0.000
SMPLS. 10.8 CATCH	0	0	0	0	1	9	19	65	0	94
29.5 MIN-MAX MEAN					0.000	0.333	0.315	5.784 83- 315 180.3		4.095 83- 315 180.3

1968

TEMP INT. C	SALINITY INTERVAL PPT									
	16.6 16.9	17.0 19.9	20.0 22.9	23.0 25.9	26.0 28.9	29.0 31.9	32.0 34.9	35.0 37.9	38.0 39.8	16.6 39.8
SMPLS. 10.8 CATCH	0	0	0	0	0	0	0	0	0	0
12.9 MIN-MAX MEAN										
SMPLS. 13.0 CATCH	0	0	0	1	4	0	6	0	0	11
15.9 MIN-MAX MEAN				0.000	0.000		5.833 97- 180 140.3			3.181 97- 180 140.3
SMPLS. 16.0 CATCH	0	0	0	2	2	3	6	8	0	21
18.9 MIN-MAX MEAN				21.500	0.500	8.666 103- 175 123.1	4.666	17.250 189- 189 189.0		11.238 103- 189 123.6
SMPLS. 19.0 CATCH	0	0	0	3	8	3	8	5	1	28
21.9 MIN-MAX MEAN				2.666	5.625	4.000	2.250	4.600	0.000	3.785
SMPLS. 22.0 CATCH	0	0	0	0	2	0	2	0	0	8
24.9 MIN-MAX MEAN					1.000		15.500	1.750		5.000
SMPLS. 25.0 CATCH	0	0	0	1	1	3	1	6	3	15
27.9 MIN-MAX MEAN				0.000	0.000	8.000	0.000	1.333	0.333	2.200
SMPLS. 28.0 CATCH	0	1	0	0	2	3	1	1	0	8
29.5 MIN-MAX MEAN		0.000			0.000	1.333	0.000	2.000		0.750
SMPLS. 10.8 CATCH	0	1	0	7	19	12	24	24	0	91
29.5 MIN-MAX MEAN		0.000		7.285	2.526	5.500 103- 175 123.1	4.666 97- 180 140.3	7.416 189- 189 189.0	0.250	5.010 97- 189 127.1

TABLE 22 (Continued)
1969

TEMP INT. C	SALINITY INTERVAL PPT									
	16.6 16.9	17.0 19.9	20.0 22.9	23.0 25.9	26.0 28.9	29.0 31.9	32.0 34.9	35.0 37.9	38.0 39.8	16.6 19.8
SMPLS. 10.8 CATCH 12.9 MIN-MAX MEAN	0	0	0	0	0	0	1 0.000	1 0.000	0	2 0.000
SMPLS. 13.0 CATCH 15.9 MIN-MAX MEAN	1 3.000	0	0	2 2.000	1 0.000	7 1.142	6 2.000	1 3.000	0	18 1.666
SMPLS. 16.0 CATCH 18.9 MIN-MAX MEAN	0	0	1 0.000	0	0	1 0.000	7 2.142	13 1.384	2 0.000	24 1.375
SMPLS. 19.0 CATCH 21.9 MIN-MAX MEAN	0	1 27.000	0	3 0.000	0	0	5 1.000	6 2.500	0	15 3.133
SMPLS. 22.0 CATCH 24.9 MIN-MAX MEAN	0	0	0	1 0.000	0	0	0	0	0	1 0.000
SMPLS. 25.0 CATCH 27.9 MIN-MAX MEAN	0	0	0	0	0	0	0	0	0	0
SMPLS. 28.0 CATCH 29.5 MIN-MAX MEAN	0	0	0	0	0	0	0	0	0	0
SMPLS. 10.8 CATCH 29.5 MIN-MAX MEAN	1 3.000	1 27.000	1 0.000	6 0.666	1 0.000	8 1.000	19 1.684	21 1.714	2 0.000	60 1.833

LUTJANIDAE - Snappers

Lutjanus campechanus (Poey) - Caribbean red snapper

A total of 122 Caribbean red snapper were taken. They occurred in all months. These fish were from 66 to 305 mm TL. The temperatures ranged from 15.4° to 28.9°C and salinities varied from 24.6 to 39.8 ppt. Specimens occurred at depths from 5 to 50 fathoms. This is the only red snapper species taken in our samples and all were relatively small specimens. Adults concentrate around rough bottom not covered in our sampling.

The red snapper fishery takes a variety of species. Carpenter (1965) listed *L. campechanus* as sixth in importance. He indicated that heavy fishing pressure may have reduced snapper stocks on the known grounds. Mississippi landings of red snapper exceeded 2.3 million pounds in 1965 (Lyles 1967).

We have taken several species of young red snappers in Mississippi Sound. The wide distribution of young fish as indicated in these studies may be an important factor in the maintenance of stocks. Little is known of the details of their life history in the study area.

Pristipomoides andersoni Ginsburg - Wenchman

Forty-seven wenchman were taken at temperatures and salinities ranging from 15.6° to 27.0°C and 26.6 to 37.9 ppt. The size range for these individuals was 155 to 271 mm TL.

All fish with one exception (5 fathoms, one specimen) were taken at 30 fathoms or deeper. This species contributes to the red snapper fishery (Carpenter 1965).

PRIACANTHIDAE - Bigeye

Priacanthus arenatus Cuvier - Bigeye

Four specimens of the bigeye were taken. One fish taken in July 1967 from 40 fathoms measured 146 mm TL and weighed 51.0 grams. The temperature was 20.6°C and the salinity was 37.2 ppt. In September 1968 a 185 mm TL specimen (50 fathoms) weighing 69.5 grams was collected at a temperature and salinity of 18.9°C and 37.4 ppt. The two 1969 (March and May) specimens were taken at a temperature range of 16.6° to 18.2°C and a salinity of 36.5 ppt. The March fish (50 fathoms) were 215 mm TL and weighed 124.0 grams. The specimen collected in May (50 fathoms) was 148 mm TL and 36.0 grams in weight.

BRANCHIOSTEGIDAE - Tilefishes

Caulolatilus cyanops Poey - Blacklined tilefish

This was the only species of tilefish collected. Eleven specimens (140 to 307 mm TL) were taken at salinities and temperatures ranging between 19.9 and 37.8 ppt and from 15.3° to 20.5°C. All fish were collected in 50 fathoms of water.

POMATOMIDAE - Bluefishes

Pomatomus saltatrix (Linnaeus) - Bluefish

Three bluefish were collected during the study, all in 1968. A January specimen measuring 123.0 mm TL and weighing 17.0 g was taken in 5 fathoms. Two specimens taken in September measured 320 and 346 mm TL and weighed 335.5 and 430.7 g respectively. The September specimens, in order as above, were taken at Stations 4 and 5 with temperatures and salinities recorded as 21.0°C and 36.5 ppt and 19.3°C and 24.9 ppt respectively. The January temperature and salinity were 14.8°C and 28.5 ppt. Although only three specimens of this fish were caught it is much more abundant in the area than this catch indicates. Charter boats and sport fishermen occasionally bring in large

catches of bluefish. We have observed numerous bluefish in passes between the barrier islands in the Mississippi Sound area.

Bluefish landings in Mississippi have shown wide fluctuations with 72,000 pounds reported in 1965.

RACHYCENTRIDAE - Cobias

Rachycentron canadum (Linnaeus) - Cobia

One cobia was taken in January 1968 at 30 fathoms with a salinity of 15.2 ppt and a temperature of 33.0°C. This fish was 510 mm in length and weighed 730.2 g.

Apparently this species is quite abundant along the shallow offshore waters as well as being present in the deep Gulf during late spring, summer and early fall. *Rachycentron canadum* is sought by sports fishermen and is of potential interest in commercial fisheries. Small quantities have been reported in Mississippi landings.

A few young cobia were taken in GMEI samples. We have collected early juveniles (Circa 30 mm) in both inshore and offshore waters.

Little is known about the life history, migration and stocks of this species in the study area. We have observed young in the industrial bottomfish catch throughout the year, indicating that at least some cobia remain in offshore Mississippi waters all year.

CARANGIDAE - Jacks, Scads and Pompanos

Caranx crysos (Mitchill) - Blue runner

A single blue runner was taken in June 1967 from 10 fathoms. The temperature was 25.6°C and the salinity was 32.0 ppt. We have often observed large schools of blue runners feeding at the surface in shallow Mississippi Sound and Gulf waters.

Chloroscombrus chrysurus (Linnaeus) - Bumper

A total of 229 bumpers was taken. Fish appeared in all months and were encountered from 5 to 30 fathoms. The greatest numbers were obtained at 5 to 10 fathoms. Miller (1965) found 90% of his specimens in 3 to 6 fathoms. Gunter (1945) took this fish at temperatures of 25.4° to 30.0°C and salinities of 16.5 to 37.2 ppt. Hildebrand (1954) stated that *C. chrysurus* occurred at temperatures from 13.0° to 29.5°C, and the salinities were from 23.0 to 37.9 ppt. Roithmayr (1965) found this fish to be a component of the northern

Gulf industrial bottomfish catch. Christmas, Gunter and Whatley (1960) found only one bumper in menhaden catch samples, but Miles and Simmons (1950) found that this species and the Atlantic thread herring comprised 50.4% of the fishes other than menhaden in the Texas menhaden fishery.

Selar crumenophthalmus (Bloch) - Bigeye scad

Eighty-three *S. crumenophthalmus* were collected at salinities and temperatures ranging from 27.0 to 37.4 ppt and 15.1° to 26.5°C. Specimens ranged in size from 100 to 235 mm TL, and a total mass of 3.605 kg was recorded. This species is uncommonly reported offshore; however, Roithmayr (1965) does list it in his study of the industrial bottomfish.

Trachurus lathami Nicholas - Rough scad

Rough scad were included in samples from all stations and in each month, but 68% of the 1,960 specimens were caught in the May samples in 1968. In these samples, total length range, with a mean of 84.6 mm, was 61 to 133 mm. Most of these were caught at Station 2 where the temperature and salinity were 20.6°C and 30.7 ppt. Temperature and salinity ranges for all samples including this species were 14.4° to 29.0°C and 23.8 to 38.7 ppt.

A total length range of 61 to 219 mm was observed. Minimum size showed a general increase from May through the rest of the year. Gunter (1945) and Hildebrand (1954) found rough scad in their samples.

Vomer setapinnis (Mitchill) - Atlantic moonfish

Vomer setapinnis was collected only in 1967 (298 specimens) and 1968 (2 specimens). A temperature and salinity range of 13.3° to 28.9°C and 30.3 to 37.9 ppt was recorded for these fish. Gunter (1945) took the moonfish at 14.2 - 30.0°C and salinities of 17.4 to 37.2 ppt. He found 96.8% of the fish at salinities above 30.0 and he took none in January and February. *Vomer setapinnis* ranged in size from 74 to 318 mm TL. The majority of specimens (253) were collected at 5 fathoms. Fish did not appear in February and October, and April was the month of greatest abundance.

GERRIDAE - Mojarra

Eucinostomus argenteus Baird and Girard - Spotfin mojarra

Twenty-five specimens were collected (1967, 6; 1968, 18; and 1969, 1). The 1967 and 1968 fish ranged in size from 87 to 119 mm

TL and were taken at temperatures and salinities ranging from 17.0° to 28.0°C and 26.6 to 37.4 ppt. The 1969 specimen (152 mm TL) occurred in February in 30 fathoms at a temperature and salinity of 14.1°C and 16.6 ppt.

POMADASYIDAE - Grunts

Orthopristis chrysopterus (Linnaeus) - Pigfish

Sixty-two pigfish were obtained in all years of the study. All months were represented with the exception of February, July and October. Specimens measured 101 to 224 mm TL. The temperatures ranged from 14.5° to 28.9°C and the salinities from 26.2 to 37.4 ppt. The largest numbers taken were from November through January, agreeing with Gunter's (1945) catch in the Gulf. Moe and Martin (1965) also show an increase in collections during the winter months. Moe and Martin (1965) mention that the pigfish is common in the more saline waters of the northern Gulf, and our records show the largest catches at salinities above 29.0 ppt.

Pigfish were in GMEI samples from April through October, ranging from 42 to 240 mm TL. A few were taken in the 5.0 to 9.9 ppt salinity range. We have found this species to be abundant in the grass beds around the Mississippi barrier islands.

SCIAENIDAE - Drums

Bairdiella chrysura (Lacépède) - Silver perch

Bairdiella chrysura was taken at a temperature range of 10.8° to 21.8°C and a salinity range of 21.8 to 33.2 ppt. Specimens appeared only in 1968 (6) and 1969 (6). These individuals ranged in size from 110 to 153 mm TL. An inshore spawning season from mid-spring to mid-summer appears to be accepted (Gunter 1945, Hildebrand and Cable 1930, Miller 1965). This species is rarely caught offshore (Gunter 1945, and Miller 1965), but it generally leaves the bay waters in winter. The present data tend to corroborate this contention since most specimens were taken in 5 fathoms of water.

Cynoscion arenarius Ginsburg - White trout

White trout comprised 2.83% of the total catch of fishes, ranking fifth in abundance. Trout, including both white and sand, comprised 5% of the industrial bottomfish catch in 1959-63 (Roithmayr 1965).

This species was taken at all stations. The highest concentrations were found at 5, 20 and 50 fathoms. The 50-fathom station produced

the highest catch per unit of effort. The maximum monthly catch per unit of effort was taken in January 1968. The 1967 and 1968 maximum catch per haul were both in March.

Diurnal differences varied. In 1967 and again in 1969 (by a factor of four) day hauls were most productive. There was little difference between catch per unit of effort for day and night hauls in 1968.

White trout were taken at temperatures ranging from 10.8° to 29.5°C. The salinity range was 16.6 to 39.8 ppt. The largest catch per unit of effort in this study was concentrated in the temperature range 16.0° to 18.9°C and salinity range 26.0 to 31.9 ppt. (Table 23).

Total length range was 71 to 453 mm. The largest specimens appeared in March (453 mm TL) and September (434 mm TL). Mean total length was 233 mm.

In March 1969 at the 50-fathom station we collected 45 (5 males and 40 females) fish with running milt and roe. Their total lengths were from 350 to 370 mm. Males were smaller (mean TL = 350.6 mm). Females averaged 357.1 mm. Gunter (1938 and 1945) reported ripe specimens from inshore waters in March, April, May and June. Guest and Gunter (1958) noted an offshore migration in the cooler months. Gunter (1945), Miller (1965) and Simmons (1951) indicated a spring and summer spawning period in the Gulf.

White trout were abundant in GMEI samples in Mississippi Sound. A winter migration to Gulf waters was indicated by reduced numbers from December through March. Young of the year started moving into the nursery area in April.

Cynoscion nothus (Holbrook) - Sand Trout

Cynoscion nothus was taken at all stations. Sizes ranged from 70 to 380 mm TL for the 104 specimens collected. Information presented by Gunter (1945) and Miller (1965) indicates that the spawning season may extend from spring through fall. This species was occasionally taken with *C. arenarius* but occurred in much smaller numbers. Temperatures and salinities ranged from 14.3° to 29.0°C and 21.6 and 38.6 ppt. A total weight of 7.994 kilograms was recorded.

GMEI samples included 120 sand trout from 994 samples. They were more evident in warm months. Similar information was given by Gunter (1945). The minimum salinity interval for this species was 10.0 to 14.9 ppt. Total length range was 22 to 224 mm. In general the salinity distribution is higher than for *C. arenarius*.

TABLE 23
DISTRIBUTION OF *CYNOSCION ARENARIUS* BY BOTTOM SALINITY
AND TEMPERATURE INTERVALS SHOWING NUMBER OF SAMPLES,
CATCH PER UNIT OF EFFORT, MINIMUM, MAXIMUM AND MEAN
TOTAL LENGTH (MM).

		1967									
		SALINITY INTERVAL PPT									
TEMP		16.6	17.0	20.0	23.0	26.0	29.0	32.0	35.0	38.0	16.6
INT.	C	16.9	19.9	22.9	25.9	28.9	31.9	34.9	37.9	39.8	39.8
10.8	SMPLS.	0	0	0	0	0	0	0	0	0	0
12.9	CATCH										
	MIN-MAX										
	MEAN										
13.0	SMPLS.	0	0	0	0	0	1	6	1	0	8
15.9	CATCH						0.000	10.666	0.000		8.000
	MIN-MAX							73- 210			73- 210
	MEAN							121.3			121.3
16.0	SMPLS.	0	0	0	0	1	1	4	13	0	19
18.9	CATCH					71.000	4.000	12.000	19.307		14.684
	MIN-MAX					76- 196	178- 206	149- 272	152- 390		76- 390
	MEAN					115.9	192.2	194.4	217.7		190.6
19.0	SMPLS.	0	0	0	0	0	2	4	21	0	27
21.9	CATCH						0.000	0.000	10.380		8.074
	MIN-MAX								172- 360		172- 360
	MEAN								269.2		269.2
22.0	SMPLS.	0	0	0	0	0	1	1	12	0	14
24.9	CATCH						24.000	1.000	3.166		4.500
	MIN-MAX						108- 247	245- 245	195- 310		108- 310
	MEAN						184.5	245.0	235.0		215.9
25.0	SMPLS.	0	0	0	0	0	4	2	18	0	24
27.9	CATCH						4.750	0.000	1.722		2.081
	MIN-MAX						160- 275		185- 277		160- 277
	MEAN						219.3		235.3		229.2
28.0	SMPLS.	0	0	0	0	0	0	2	0	0	2
29.9	CATCH							5.000			5.000
	MIN-MAX							190- 280			140- 280
	MEAN							229.7			229.7
10.8	SMPLS.	0	0	0	0	1	9	19	65	0	94
29.9	CATCH					71.000	5.222	6.473	8.276		8.287
	MIN-MAX					76- 196	108- 275	73- 280	152- 390		73- 390
	MEAN					115.9	199.2	159.7	243.9		211.8

		1968									
		SALINITY INTERVAL PPT									
TEMP		16.6	17.0	20.0	23.0	26.0	29.0	32.0	35.0	38.0	16.6
INT.	C	16.9	19.9	22.9	25.9	28.9	31.9	34.9	37.9	39.8	39.8
10.8	SMPLS.	0	0	0	0	0	0	0	0	0	0
12.9	CATCH										
	MIN-MAX										
	MEAN										
13.0	SMPLS.	0	0	0	0	1	4	6	0	0	11
15.9	CATCH					0.000	42.750	6.500			14.090
	MIN-MAX						85- 242	147- 422			85- 422
	MEAN						127.7	273.1			163.2
16.0	SMPLS.	0	0	0	2	2	3	6	8	0	21
18.9	CATCH				12.500	10.500	113.333	7.500	4.375		22.190
	MIN-MAX				203- 329	117- 226	157- 275	161- 320	157- 387		117- 387
	MEAN				261.6	183.8	204.6	243.3	234.8		216.1
19.0	SMPLS.	0	0	0	3	8	3	8	5	1	28
21.9	CATCH				0.333	2.375	2.000	5.125	6.600	1.000	3.607
	MIN-MAX				298- 258	221- 334	113- 187	222- 332	205- 357	206- 206	113- 357
	MEAN				258.0	262.4	144.1	282.0	260.3	206.0	267.0
22.0	SMPLS.	0	0	0	0	2	0	2	4	0	8
24.9	CATCH					0.000		17.500	2.250		5.500
	MIN-MAX							200- 314	199- 276		199- 314
	MEAN							271.8	232.2		263.7
25.0	SMPLS.	0	0	0	1	1	3	1	6	3	15
27.9	CATCH				0.000	0.000	0.000	1.000	2.000	0.000	0.866
	MIN-MAX							434- 434	182- 293		182- 434
	MEAN							434.0	212.5		229.5
28.0	SMPLS.	0	1	0	0	2	3	1	1	0	8
29.9	CATCH		0.000			1.500	0.000	0.000	0.000		0.375
	MIN-MAX					163- 179					163- 179
	MEAN					172.6					172.6
10.8	SMPLS.	0	1	0	7	19	12	24	24	4	91
29.9	CATCH		0.000		3.714	11.263	28.833	6.708	3.708	0.250	9.197
	MIN-MAX				203- 329	85- 334	113- 275	147- 434	157- 387	206- 206	85- 434
	MEAN				261.4	151.3	202.8	270.2	241.0	206.0	216.9

TABLE 23 (Continued)
1969

TEMP INT. C	SALINITY INTERVAL PPT										
	16.4 16.9	17.0 19.9	20.0 22.9	23.0 25.9	26.0 28.9	29.0 31.9	32.0 34.9	35.0 37.9	38.0 39.8	16.4 30.8	16.4 30.8
10.8 12.9 MEAN	0	0	0	0	0	0	1 1.000	1 0.000	0	2 0.500	2 98.0
13.0 15.9 MEAN	1 5.000	0	0	2 11.000	1 2.000	7 2.000	6 3.666	1 0.000	0	18 3.611	18 71-310 194.8
16.0 18.9 MEAN	0	0	1 0.000	0	0	1 1.000	7 32.857	13 48.000	2 7.000	24 36.208	24 192-192 192.0
19.0 21.9 MEAN	0	1 1.000	0	3 0.666	0	0	5 8.700	6 1.333	0	15 3.466	15 265-265 265.0
22.0 24.9 MEAN	0	0	0	1 12.000	0	0	0	0	0	1 12.000	1 183-213 197.4
25.0 27.9 MEAN	0	0	0	0	0	0	0	0	0	0	0
28.0 29.5 MEAN	0	0	0	0	0	0	0	0	0	0	0
10.8 29.5 MEAN	1 5.000	1 1.000	1 0.000	6 6.000	1 2.000	8 1.875	19 15.473	21 30.095	2 7.000	60 16.650	60 236-310 268.0
	310	265	265	110-290	71-158	75-218	96-332	192-453	224-315	71-453	265.0
	268.0	265.0		214.0	114.5	158.5	223.5	294.6	253.4	233.0	

Equetus acuminatus (Bloch and Schneider) - Cubbyu

Thirty-eight specimens (108 to 289 mm TL) were taken at temperatures and salinities ranging from 16.4° to 27.2°C and 23.2 to 37.9 ppt. *Equetus acuminatus* appeared from 20 to 50 fathoms. Roithmayr (1965) does not list this species.

Larimus fasciatus Holbrook - Banded drum

Specimens were taken in 1967 (47), 1968 (13), and 1969 (9). They were collected at temperatures and salinities from 14.5° to 28.9°C and 26.6 to 38.7 ppt respectively. Gunter (1945) took four specimens in Texas offshore waters at a salinity range of 26.7 to 35.2. A total length range from 94 to 202 mm TL was noted for these individuals. The majority of specimens were taken at 20 and 30 fathoms, and sizes taken offshore were rather consistent throughout the year. Hildebrand and Cable (1934) reported spawning from May to October.

GMEI samples included banded drum with a total length range of 21 to 189 mm and all were taken at salinities above 20.0 ppt.

Leiostomus xanthurus Lacépède - Spot.

The spot was represented by 6,457 specimens which accounted for 6.90% of the total fish catch. Fish were taken in all months and at all stations; however, *Leiostomus* was found in greater abundance at the deeper stations.

During 1967 and 1968 night hauls were more productive than those taken in the day. Numbers in day hauls far out-ranked night hauls in 1969. The largest catch per unit of effort for the 3-year period occurred in May (40 fathoms) at a mean temperature and salinity of 19.5°C and 35.1 ppt and in December (50 fathoms) at a mean temperature of 21.5°C and a mean salinity of 33.2 ppt. Temperatures and salinities for all specimens ranged from 14.1° to 29.5°C and 24.9 to 38.7 ppt. A definite preference for temperatures from 19.0° to 21.9°C was evident. The greatest catch per unit of effort in all three years was at salinities from 32.0 to 37.9 ppt (Table 24).

There appears to be an offshore movement as the spot increases in size, and a late fall and winter offshore spawning period is believed to occur. Gunter (1945) found fish with well developed roe and milt in early November and January and noted spent individuals in late January. Dawson (1958) observed ripe fish during October, December and February off North Carolina. Spots spawn in their second year (Pearson 1929, Hildebrand and Cable 1930, Dawson 1958). A size approximately 200 mm is attained by two years. Nelson (1969) found that fish of this size group are primarily concentrated in 15 fathoms of water and deeper during January and February. He remarked that, in the northeastern Gulf, spawning apparently occurs in the deeper offshore waters.

Roithmayr (1965) found *L. xanthurus* to be the second most abundant species in the northern Gulf of Mexico industrial bottomfish industry. *Micropogon undulatus* ranked first. These results correspond to previous findings of Gunter (1936, 1938a, 1941 and 1945) concerning the relative abundance of shallow Gulf fishes.

Menticirrhus americanus (Linnaeus) - Shoemaker

A total of 139 southern kingfish ranging from 95 to 330 mm TL were collected. These were taken in all months with the exception of July and October. The greatest numbers were collected in January, March and May with the peak in January. Gunter (1938c and 1945) noticed an offshore migration of these fish from Louisiana and Texas during colder months. Our specimens were obtained at temperatures ranging from 14.1° to 28.9°C and salinities from 24.6 to 37.4 ppt. Moe and Martin (1965) state that this species is uncommon in low-salinity waters. Our data show that this fish prefers waters ranging from 23.0 to

TABLE 24
DISTRIBUTION OF *LEIOSTOMUS XANTHURUS* BY BOTTOM SALINITY AND
TEMPERATURE INTERVALS SHOWING NUMBER OF SAMPLES, CATCH PER
UNIT OF EFFORT, MINIMUM, MAXIMUM AND MEAN TOTAL LENGTH (MM).

1967

		SALINITY INTERVAL PPT										
TEMP INT. C		16.6 16.9	17.0 19.9	20.0 22.9	23.0 25.9	26.0 28.9	29.0 31.9	32.0 34.9	35.0 37.9	38.0 39.8	16.6 39.8	
10.8	SMPLS.	0	0	0	0	0	0	0	0	0	0	
12.9	CATCH											
	MIN-MAX											
	MEAN											
13.0	SMPLS.	0	0	0	0	0	1	6	1	0	8	
15.9	CATCH						0.000	1.500	0.000		1.125	
	MIN-MAX							170-	192		170-	
	MEAN							184.4			184.4	
16.0	SMPLS.	0	0	0	0	1	1	4	13	0	19	
18.9	CATCH					0.000	2.000	18.750	13.230		13.105	
	MIN-MAX						158-	198	155-	236	180-	251
	MEAN						178.0	203.6	206.7		155-	205.5
19.0	SMPLS.	0	0	0	0	0	2	4	21	0	27	
21.9	CATCH						0.000	136.250	24.047		38.888	
	MIN-MAX							185-	230	126-	290	
	MEAN							203.2	195.6		126-	197.7
22.0	SMPLS.	0	0	0	0	0	1	1	12	0	14	
24.9	CATCH						0.000	0.000	3.833		3.285	
	MIN-MAX								193-	264	193-	
	MEAN								212.5		212.5	
25.0	SMPLS.	0	0	0	0	0	4	2	18	0	24	
27.9	CATCH						3.500	0.000	25.166		19.458	
	MIN-MAX						140-	210	175-	230	140-	
	MEAN						173.5	203.7			200.4	
28.0	SMPLS.	0	0	0	0	0	0	2	0	0	2	
29.5	CATCH							3.500			3.500	
	MIN-MAX							147-	192		147-	
	MEAN							163.8			163.8	
10.8	SMPLS.	0	0	0	0	1	9	19	65	0	94	
29.5	CATCH					0.000	1.777	33.473	18.092		19.446	
	MIN-MAX						140-	210	147-	236	126-	
	MEAN						174.0	201.0	201.7		201.0	

1968

		SALINITY INTERVAL PPT									
TEMP INT. C		16.6 16.9	17.0 19.9	20.0 22.9	23.0 25.9	26.0 28.9	29.0 31.9	32.0 34.9	35.0 37.9	38.0 39.8	16.6 39.8
10.8	SMPLS.	0	0	0	0	0	0	0	0	0	0
12.9	CATCH										
	MIN-MAX										
	MEAN										
13.0	SMPLS.	0	0	0	1	4	0	6	0	0	11
15.9	CATCH				0.000	7.000		2.166			3.727
	MIN-MAX					148-	234	143-	232		143-
	MEAN					174.8		196.4			181.6
16.0	SMPLS.	0	0	0	2	2	3	6	8	0	21
18.9	CATCH				0.000	11.500	0.666	3.500	10.375		6.142
	MIN-MAX					153-	230	220-	224	194-	222
	MEAN					185.3	222.0	208.2	199.9		153-
19.0	SMPLS.	0	0	0	3	8	3	8	5	1	28
21.9	CATCH				1.666	0.500	12.333	84.000	105.400	3.000	44.571
	MIN-MAX				183-	208	181-	203	102-	255	180-
	MEAN				191.8	192.2	202.8	215.2	217.8	190-	207
22.0	SMPLS.	0	0	0	0	2	0	2	4	0	8
24.9	CATCH					0.000		0.000	1.750		0.875
	MIN-MAX								183-	254	183-
	MEAN								218.0		218.0
25.0	SMPLS.	0	0	0	1	1	3	1	6	3	15
27.9	CATCH				0.000	0.000	1.000	0.000	1.500	1.000	0.866
	MIN-MAX								192-	195	205-
	MEAN								177.2	209.0	213
28.0	SMPLS.	0	1	0	0	2	3	1	1	0	8
29.5	CATCH		0.000			2.000	1.666	0.000	0.000		1.125
	MIN-MAX					153-	189	179-	210		153-
	MEAN					175.2	201.2				210
10.8	SMPLS.	0	1	0	7	19	12	24	24	4	91
29.5	CATCH		0.000		0.714	3.105	3.750	29.416	26.083	1.500	15.901
	MIN-MAX				183-	208	148-	234	102-	255	143-
	MEAN				191.8	180.1	203.9	213.5	208.8	203.1	102-

TABLE 24 (Continued)

1969

SALINITY INTERVAL PPT

TEMP INT. C	16.6 16.9	17.0 19.9	20.0 22.9	23.0 25.9	26.0 28.9	29.0 31.9	32.0 34.9	35.0 37.9	38.0 39.8	36.6 39.8
SMPLS. 10.8 CATCH	0	0	0	0	0	0	1	1	0	2
12.9 MIN-MAX							0.000	0.000		0.000
MEAN										
SMPLS. 13.0 CATCH	1	0	0	2	1	7	6	1	0	18
15.9 MIN-MAX	0.000			3.000	0.000	3.142	1.500	0.000		2.055
MEAN				162- 210		142- 195	126- 225			128- 225
				182.3		160.1	169.2			165.9
SMPLS. 16.0 CATCH	0	0	1	0	0	1	7	13	2	24
18.9 MIN-MAX			0.000			0.000	4.428	10.230	4.000	7.166
MEAN							110- 241	188- 257	190- 220	110- 257
							205.0	212.6	206.0	210.9
SMPLS. 19.0 CATCH	0	1	0	3	0	0	5	6	0	15
21.9 MIN-MAX		0.000		2.333			0.000	501.666		201.133
MEAN				196- 215				172- 261		172- 261
				205.4				211.4		211.0
SMPLS. 22.0 CATCH	0	0	0	1	0	0	0	0	0	1
24.9 MIN-MAX				0.060						0.000
MEAN										
SMPLS. 25.0 CATCH	0	0	0	0	0	0	0	0	0	0
27.9 MIN-MAX										
MEAN										
SMPLS. 28.0 CATCH	0	0	0	0	0	0	0	0	0	0
29.5 MIN-MAX										
MEAN										
SMPLS. 10.8 CATCH	1	1	1	6	1	8	19	21	2	60
29.5 MIN-MAX	0.000	0.000	0.000	7.166	0.000	7.750	2.105	149.666	4.000	53.766
MEAN				162- 215		142- 195	110- 241	172- 261	190- 220	110- 261
				194.7		160.1	196.9	217.0	206.0	205.8

28.9 ppt. Bearden (1963) suggested that this fish is possibly euryhaline but Gunter (1945) did not take *M. americanus* at a salinity lower than 14.5 ppt. It was not taken in Mississippi GMEI samples at less than 5 ppt.

Hildebrand and Cable (1934) found that the shoemaker may spawn in both inshore and offshore waters from April through September in the Beaufort, North Carolina, area and found young fish in both areas. Gunter (1938c) found fish with well-developed roe from April to June in offshore waters in Louisiana. Gunter (1945) also found ripening fish in April and November while working in Aransas Bay, Texas, indicating a very long spawning period in the Gulf. Reid (1954) took ripe females in April and August at Cedar Key, Florida. Our smallest individual was taken in January. Moe and Martin (1965) found their smallest fish in the same month; however, they collected small fish ranging 44 to 52 mm during all months except May and suggested fall-spring spawning period in the Gulf. GMEI samples included specimens from 17 to 255 mm TL with a mean of 86.2 mm.

Kingfish are utilized in Mississippi waters by both commercial and sports fishermen. Fishery statistics (Lyles 1967) show a maximum Mississippi catch of 1.3 million pounds in 1953.

Micropogon undulatus (Linnaeus) - Croaker

Croaker was the most abundant species in our samples, comprising 34.91% of the catch. The greatest annual concentrations appeared in September (1967) and in May (1968 and 1969.)

Bathymetric distribution of catch per unit of effort shows the highest average at 40 and 50 fathoms. Seasonal catch per unit of effort was highest in the spring (March, April and May) and fall.

At the 5-fathom station the highest catch occurred in fall and summer. Catches were higher at 10 and 20 fathoms in fall and winter and in spring and summer at 30 fathoms. At 40 and 50 fathoms, winter and summer catches were higher. In general, night catches were higher but there were exceptions.

Croakers were collected at temperatures of 13.0° to 29.5°C and at salinities 16.6 to 39.8 ppt. Maximum catches per unit of effort occurred at temperatures between 19.0° and 21.9°C. The best average catch occurred at the salinity interval 35.0 to 39.8 ppt. (Table 25).

The TL limits of croakers in our samples were 100 and 327 mm with a mean at 192 mm. Specimens under 110 mm TL were collected in January, February, March, May and September. The largest specimens (315 and 327 mm) were taken in March. Monthly mean TL ranged from 161 mm (September) to 209 mm (January) in 1967 and 170 mm (February) to 211 mm (March) in 1968.

The croaker was the third most abundant species in GMEI samples. Croakers were collected in all seasons and at all salinities with a total length range of 7 to 402 mm. The mean length was 111.9 mm.

In general, our data support the fall migration (at about 100-mm minimum according to our data) offshore and a major spawning period in the fall as reported by such authors as Gunter (1945), Hildebrand (1954), Springer and Bullis (1956), Miller (1965) and Nelson (1969). Roithmayr (1965) suggested that croakers nearing the size of 180 mm are approaching 2 years of age and are capable of spawning for the first time. Fish of 210 mm or so in size were in their third year, and large croakers (averaging 300 mm) were estimated to be between 5 and 7 years of age (Roithmayr 1965). These estimates of age are about double those of Gunter (1945) and Herke (1971) and are probably in error.

There is already heavy fishing pressure on this species to supply over 50% of the commercial bottomfish taken from the Gulf (Roithmayr 1965). The rapidly developing market for croaker as a food fish will probably increase the pressure on the larger fish.

TABLE 25 (Continued)
1969

TEMP INT. C	SALINITY INTERVAL PPT										
	16.6 16.9	17.0 19.9	20.0 22.9	23.0 25.9	26.0 28.9	29.0 31.9	32.0 34.9	35.0 37.9	38.0 39.8	36.6 39.8	
SMPLS. 10.8 CATCH 12.9 MIN-MAX MEAN	0	0	0	0	0	0	1 0.000	1 0.000	0	2 0.000	
SMPLS. 13.0 CATCH 15.9 MIN-MAX MEAN	1 4.000 190- 230 206.7	0	0 3.000 140- 170 150.0	2 0.000	1 0.000	7 1.714 137- 225 181.7	6 65.666 155- 299 207.1	1 28.000 170- 210 190.8	0	18 24.666 137- 299 200.4	
SMPLS. 16.0 CATCH 18.9 MIN-MAX MEAN	0	0 19.000 180- 215 200.1	1 0.000	0 3 0.000 187- 226 203.6	0	1 0.000	7 343.000 146- 250 198.8	13 235.857 103- 257 198.8	13 99.076 105- 327 202.2	2 158.000 146- 217 190.5	24 150.708 103- 327 199.4
SMPLS. 19.0 CATCH 21.9 MIN-MAX MEAN	0	1 0.000	0	3 0.000	0	0	5 0.600 156- 190 175.3	6 687.000 107- 268 203.6	0	15 276.600 107- 268 203.3	
SMPLS. 22.0 CATCH 24.9 MIN-MAX MEAN	0	0	0	0.000	0	0	0	0	0	1 0.000	
SMPLS. 25.0 CATCH 27.9 MIN-MAX MEAN	0	0	0	0	0	0	0	0	0	0	
SMPLS. 28.0 CATCH 29.9 MIN-MAX MEAN	0	0	0	0	0	0	0	0	0	0	
SMPLS. 10.8 CATCH 29.9 MIN-MAX MEAN	1 4.000 190- 230 206.7	1 0.000	1 19.000 180- 215 200.1	6 5.000 140- 226 192.9	0.000	1 44.375 137- 258 197.0	8 107.789 103- 299 200.2	19 258.952 105- 327 202.4	21 158.000 146- 217 190.5	60 136.833 103- 327 200.2	

Roithmayr (1965) found that the croaker maintained adequate stocks under increasing pressure from 1959 to 1963. Stocks still seem to be adequate.

Pogonias cromis (Linnaeus) - Black drum

In November 1967 one black drum, 662 mm TL, 4.3 kg in weight was collected from 5 fathoms. The temperature and salinity were 17.0°C and 32.4 ppt. In 1969 four specimens were collected at Station 1, one at Station 2, and one at Station 5. Five of these were taken in March (67 at 55 mm TL and 0.44 to 2.0 kg) and one in January (593 mm TL and 3.4 kg). For the 1969 specimens temperatures ranged between 14.2° to 16.9°C and salinities between 29.9 and 37.4 ppt.

MULLIDAE - Goatfishes

Mullus auratus Jordan and Gilbert - Red goatfish

One hundred sixty-two specimens were collected during the study. Moe and Martin (1965) reported three fish from a depth of 13.3 fathoms (24.4 meters) at a temperature of 30.0°C and a salinity of 35.6 ppt. In the present survey temperatures and salinities ranged between 14.0° to 27.0°C and 16.6 to 38.2 ppt respectively. A size range of 115

to 228 mm TL was recorded. The majority of *M. auratus* were collected at the deeper offshore stations (30 and 40 fathoms).

SPARIDAE - Porgies

Archosargus probatocephalus (Walbaum) - Sheepshead

The sheepshead was encountered on three occasions, twice in 1967 and once in 1969. Single specimens were taken from Stations 1 and 2 in 1967 in April and January, respectively. The January temperature and salinity were 23.1°C and 31.9 ppt. In April, temperature and salinity were 16.0 and 34.7 ppt. The January and April specimens measured 546 and 320 mm TL and weighed 4.6 and 1.4 kg respectively. In January 1969 the third fish measuring 490 mm TL and weighing 1.1 kg was taken from 20 fathoms at a temperature and salinity of 16.7°C and 31.5 ppt.

Lagodon rhomboides (Linnaeus) - Pinfish

This species was taken in every month except April. A total number of 1,990 fish was recorded. They comprised 2.12% of the entire catch of fishes. Pinfish were taken in greatest abundance at 30, 40 and 50 fathoms. The greatest number during the three years was taken in March. This is due to a very heavy catch in March 1969 (1,015). In 1967 the largest catch per unit of effort was in August. The greatest catch per unit of effort in 1968 was in November. A comparison of total day and night hauls shows a higher catch per unit of effort for night hauls in 1967 and 1968 and for day hauls in 1969. Night hauls at 50 fathoms excelled in catch per unit of effort. These data highlight for the first time the extensive offshore distribution of this species.

Temperatures ranged from 13.5° to 28.7° C with salinities between 24.9 and 37.8 ppt. There appeared to be a preference for temperatures from 16.0° to 27.9° C and salinities from both 23.0 to 38.9 ppt and 35.0 to 37.9 ppt (Table 26).

Springer and Woodburn (1960) noted a diminishing number of fish inshore after December. Caldwell (1957) suggested an offshore migration in cold weather. Moe and Martin (1965) corroborated the offshore movement and stated that their specimens were probably of the first year class (79 to 109 mm TL). Our data are in agreement since we observed specimens of similar size (97 to 103 mm TL) beginning to occur in catches during November, December and January. All fish ranged from 97 to 217 mm TL. An approximate total weight of 145.239 kilograms was recorded.

Darnell (1958) noted a change in food habits as the pinfish

NEKTONIC AND BENTHIC FAUNAS

TABLE 26
DISTRIBUTION OF *LAGODON RHOMBOIDES* BY BOTTOM SALINITY AND
TEMPERATURE INTERVALS SHOWING NUMBER OF SAMPLES, CATCH PER
UNIT OF EFFORT, MINIMUM, MAXIMUM AND MEAN TOTAL LENGTH (MM).

1967

		SALINITY INTERVAL PPT									
TEMP	INT.	16.6	17.0	20.0	23.0	26.0	29.0	32.0	35.0	38.0	16.6
C		16.9	19.9	22.9	25.9	28.9	31.9	34.9	37.9	39.8	39.8
	SMPLS.	0	0	0	0	0	0	0	0	0	0
	CATCH										
	MIN-MAX										
	MEAN										
	SMPLS.	0	0	0	0	0	1	6	1	0	8
	CATCH						0.000	0.166	0.000		0.125
	MIN-MAX							113- 113			113- 113
	MEAN							113.0			113.0
	SMPLS.	0	0	0	0	1	1	4	13	0	19
	CATCH					0.000	0.000	0.000	4.692		3.210
	MIN-MAX								115- 198		115- 198
	MEAN								170.6		170.6
	SMPLS.	0	0	0	0	0	2	4	21	0	27
	CATCH						2.500	0.000	3.571		2.962
	MIN-MAX						105- 134		146- 215		105- 215
	MEAN						116.6		176.1		172.4
	SMPLS.	0	0	0	0	0	1	1	12	0	14
	CATCH						0.000	0.000	4.666		4.000
	MIN-MAX								147- 203		147- 203
	MEAN								171.4		171.4
	SMPLS.	0	0	0	0	0	4	2	18	0	24
	CATCH						0.250	0.000	0.222		4.708
	MIN-MAX						165- 165		146- 202		146- 202
	MEAN						165.0		176.7		176.6
	SMPLS.	0	0	0	0	0	0	2	0	0	2
	CATCH							3.000			3.000
	MIN-MAX							130- 176			130- 176
	MEAN							151.6			151.6
	SMPLS.	0	0	0	0	1	9	19	65	0	94
	CATCH					0.000	0.666	0.368	4.676		3.372
	MIN-MAX						105- 185	113- 176	115- 215		105- 215
	MEAN						124.6	146.1	175.1		173.5

1968

		SALINITY INTERVAL PPT									
TEMP	INT.	16.6	17.0	20.0	23.0	26.0	29.0	32.0	35.0	38.0	16.6
C		16.9	19.9	22.9	25.9	28.9	31.9	34.9	37.9	39.8	39.8
	SMPLS.	0	0	0	0	0	0	0	0	0	0
	CATCH										
	MIN-MAX										
	MEAN										
	SMPLS.	0	0	0	1	4	0	6	0	0	11
	CATCH				0.000	0.000		2.666			1.454
	MIN-MAX							97- 203			97- 203
	MEAN							170.7			170.7
	SMPLS.	0	0	0	2	2	3	6	8	0	21
	CATCH				0.000	0.000	0.000	0.500	4.500		1.857
	MIN-MAX							112- 190	101- 190		101- 190
	MEAN							157.3	149.4		150.0
	SMPLS.	0	0	0	3	8	3	8	5	1	28
	CATCH				1.333	1.625	10.333	1.500	1.600	0.000	2.428
	MIN-MAX				177- 191	155- 182	134- 188	157- 190	165- 217		134- 217
	MEAN				182.7	171.3	160.2	171.4	184.2		168.4
	SMPLS.	0	0	0	0	2	0	2	4	0	8
	CATCH					76.500		0.000	0.750		19.500
	MIN-MAX					140- 209			150- 169		140- 209
	MEAN					180.2			162.0		179.6
	SMPLS.	0	0	0	1	1	3	1	6	3	15
	CATCH				0.000	0.000	0.333	1.000	2.333	0.000	1.066
	MIN-MAX						188- 188	137- 137	134- 192		134- 192
	MEAN						188.0	137.0	171.9		170.7
	SMPLS.	0	1	0	0	2	3	1	1	0	8
	CATCH		0.000			0.000	0.000	0.000	0.000		0.000
	MIN-MAX										
	MEAN										
	SMPLS.	0	1	0	7	19	12	24	24	4	91
	CATCH		0.000		0.571	8.736	2.066	1.333	2.541	0.000	3.251
	MIN-MAX				177- 191	140- 209	134- 188	97- 203	101- 217		97- 217
	MEAN				182.7	179.1	161.1	168.6	159.7		170.5

TABLE 26 (Continued)
1969

TEMP INT. C	SALINITY INTERVAL PPT									
	16.6 18.9	17.0 19.9	20.0 22.9	23.0 25.9	26.0 28.9	29.0 31.9	32.0 34.9	35.0 37.9	38.0 39.8	16.6 39.8
SMPLS. 10.8 CATCH 12.9 MIN-MAX MEAN	0	0	0	0	0	0	1 0.000	1 0.000	0	2 0.000
SMPLS. 13.0 CATCH 15.9 MIN-MAX MEAN	1 0.000	0	0	2 0.000	1 0.000	7 0.285 103-111 157-165.0	6 0.333 173	1 0.000	0	18 0.222 103-173 136.0
SMPLS. 16.0 CATCH 18.9 MIN-MAX MEAN	0	0	1 0.000	0	0	1 0.000	7 0.142 175-175.0	13 78.076 156-206 179.1	2 0.000	24 42.333 136-200 179.1
SMPLS. 19.0 CATCH 21.9 MIN-MAX MEAN	0	1 0.000	0	3 118.333 140-208 183.9	0	0	5 0.000	6 0.500 160-180 173.3	0	15 23.866 140-208 183.6
SMPLS. 22.0 CATCH 24.9 MIN-MAX MEAN	0	0	0	1 0.000	0	0	0	0	0	1 0.000
SMPLS. 25.0 CATCH 27.9 MIN-MAX MEAN	0	0	0	0	0	0	0	0	0	0
SMPLS. 28.0 CATCH 29.9 MIN-MAX MEAN	0	0	0	0	0	0	0	0	0	0
SMPLS. 10.8 CATCH 29.9 MIN-MAX MEAN	1 0.000	1 0.000	1 0.000	6 59.166 140-208 183.9	1 0.000	8 0.250 103-111 157-165.0	19 0.157 175-168.3	21 48.476 156-206 179.0	2 0.000	60 22.966 103-208 180.0

increases in size, and suggested a food preference change may be an incentive for the larger individual to migrate to more advantageous feeding areas. Possibly the larger fish are more susceptible to the varying extremes of temperature and dissolved oxygen occurring in shallower waters (Darnell 1958) and seek deeper offshore waters.

No noticeable increase in numbers was observed during our winter collections; however, as was mentioned previously, the March hauls were quite productive.

Hildebrand and Cable (1938), Gunter (1945), Springer and Woodburn (1960), Caldwell (1957), Moe and Martin (1965), and Cameron (1969) concur that spawning occurs in deep offshore waters during late fall and early winter. Cameron (1969) remarked that the pinfish has not been observed spawning, and records of ripe individuals are few. On March 21, 1969 in 50 fathoms of water, we took 589 large individuals (158 to 204 mm TL). These fish were in spawning condition (running milt and roe). Upon examination of several of the larger fish, which proved to be female, the ovaries were noted to be quite distended. This extends the previously known spawning season.

Young pinfish with total lengths 11 to 18 mm were found in GMEI plankton samples from Dog Keys Pass from December through March. Larger specimens (19 to 211 mm TL) appeared in trawl and

seine samples through a wide range of salinity. They were more abundant in the summer than in winter. We have observed this important forage species in largest numbers in the grass beds around the offshore barrier islands.

Pagrus sedecim Ginsburg - Red porgy

Three red porgies were encountered, two in March 1967 and one in February 1969. All of these were taken at 50 fathoms. The two March specimens measured 264 and 370 mm TL and weighed 243.7 and 734.7 g respectively. The temperature and salinity at this time were 20.0°C and 37.8 ppt. The February fish measured 169 mm TL and was collected at a temperature of 16.0 and a salinity of 34.8 ppt. Moe and Martin (1965) took one specimen (317 mm TL) in 25 fathoms.

Stenotomus caprinus Bean - Longspined porgy

Stenotomus caprinus appeared in large numbers during all months. The greatest numbers were encountered during May and June. This species was the second most abundant fish collected (26,612 specimens, comprising 28.4% of the total catch). Hildebrand (1954) noted *S. caprinus* to be one of the most abundant fishes on the brown shrimp grounds. The first record from Texas was listed (*Otrynter caprinus*) by Gunter and Knapp (1951). Springer and Bullis often found *S. caprinus* to be the dominant organism taken in northern Gulf hauls. Miller (1965) remarked on the scarcity of data concerning this species in northern Gulf surveys.

Caldwell (1955) reported that *S. caprinus* is limited to depths of 3 fathoms (5.5 meters) or greater and is reported no deeper than 100 (183 meters) fathoms, with the greatest abundance from 30 to 50 fathoms.

A total of only 63 specimens was collected at our 5-fathom station. The largest catch per unit of effort in 1967, 1968 and 1969 occurred in June, May and March respectively. A comparison of day and night hauls shows a greater catch per unit of effort at night for each of the three years. The largest catch per unit of effort in the three years occurred at the 40-fathom depth in 1969, with temperature and salinity means at 23.0°C and 36.9 ppt.

Caldwell (1955) stated that *S. caprinus* has been reported at bottom temperatures ranging from 56.6° to 83.3° F (13.7° to 28.5° C). During our study temperatures ranged from 14.0° to 29.0° C, but a preference for temperatures in the range 19.0° to 27.9° C was noted (Table 27).

TABLE 27
DISTRIBUTION OF *STENOTOMUS CAPRINUS* BY BOTTOM SALINITY AND
TEMPERATURE INTERVALS SHOWING NUMBER OF SAMPLES, CATCH PER
UNIT OF EFFORT, MINIMUM, MAXIMUM AND MEAN TOTAL LENGTH (MM).

		SALINITY INTERVAL PPT									
TEMP INT. C		16.6 16.9	17.0 19.9	20.0 22.9	23.0 25.9	26.0 28.9	29.0 31.9	32.0 34.9	35.0 37.9	38.0 39.8	38.6 39.8
10.8	SMPLS. CATCH	0	0	0	0	0	0	0	0	0	0
12.9	MIN-MAX										
	MEAN										
13.0	SMPLS. CATCH	0	0	0	0	0	1	6	1	0	8
15.9	MIN-MAX						0.000	0.166	0.000		0.125
	MEAN						100-100	100-100		100-100	100.0
16.0	SMPLS. CATCH	0	0	0	0	1	1	4	13	0	19
18.9	MIN-MAX					0.000	0.000	0.250	76.157		24.157
	MEAN						105-105	95-202	105.0	158.1	158.0
19.0	SMPLS. CATCH	0	0	0	0	0	2	4	21	0	27
21.9	MIN-MAX						0.000	288.500	209.476		205.666
	MEAN						80-183	74-219	126.7	143.4	142.0
22.0	SMPLS. CATCH	0	0	0	0	0	1	1	12	0	14
24.9	MIN-MAX						0.000	0.000	118.500		101.571
	MEAN							65-209	141.6	141.6	141.6
25.0	SMPLS. CATCH	0	0	0	0	0	4	2	18	0	24
27.9	MIN-MAX						1.000	0.000	164.222		123.333
	MEAN						77-93	84.7	74-207	139.6	139.3
28.0	SMPLS. CATCH	0	0	0	0	0	0	2	0	0	2
29.5	MIN-MAX							3.000			3.000
	MEAN							72-101		89.3	89.3
10.8	SMPLS. CATCH	0	0	0	0	1	9	19	65	0	94
29.5	MIN-MAX					0.000	0.444	61.157	150.261		116.308
	MEAN						77-93	84.7	72-183	65-219	143.6

		SALINITY INTERVAL PPT									
TEMP INT. C		16.6 16.9	17.0 19.9	20.0 22.9	23.0 25.9	26.0 28.9	29.0 31.9	32.0 34.9	35.0 37.9	38.0 39.8	38.6 39.8
10.8	SMPLS. CATCH	0	0	0	0	0	0	0	0	0	0
12.9	MIN-MAX										
	MEAN										
13.0	SMPLS. CATCH	0	0	0	1	4	0	6	0	0	11
15.9	MIN-MAX				0.000	0.000		68.833			37.545
	MEAN							107-186		107-186	138.6
16.0	SMPLS. CATCH	0	0	0	2	2	3	6	8	0	21
18.9	MIN-MAX				4.500	2.500	4.333	170.833	12.125		54.714
	MEAN				111-130	101-256	85-131	102-182	66-178	66-256	127.3
19.0	SMPLS. CATCH	0	0	0	3	8	3	8	5	1	29
21.9	MIN-MAX				201.000	524.000	105.666	104.000	154.800	209.000	247.392
	MEAN				98-185	87-190	103-186	53-185	81-194	98-143	53-194
22.0	SMPLS. CATCH	0	0	0	0	2	0	2	4	0	8
24.9	MIN-MAX					188.500		0.000	128.250		111.250
	MEAN					90-178		64-175	95.1	64-178	111.7
25.0	SMPLS. CATCH	0	0	0	1	1	3	1	6	3	15
27.9	MIN-MAX				0.000	6.000	138.666	35.000	136.333	11.666	87.333
	MEAN					79-93	55-170	69-102	65-187	64-105	55-187
28.0	SMPLS. CATCH	0	1	0	0	2	3	1	1	0	8
29.5	MIN-MAX		0.000			2.000	23.000	0.000	500.000		71.428
	MEAN					66-76	58-107	86.6	56-112	86.4	86.1
10.8	SMPLS. CATCH	0	1	0	7	19	12	24	24	4	91
29.5	MIN-MAX		0.000		87.428	241.263	67.916	96.041	112.583	61.000	123.758
	MEAN				98-185	66-256	55-186	53-186	56-194	64-143	53-256
					137.6	134.3	117.8	127.0	114.8	113.2	123.2

TABLE 27 (Continued)
1969

TEMP INT. C	SALINITY INTERVAL PPT										
	16.6 16.9	17.0 19.9	20.0 22.9	23.0 25.9	26.0 28.9	29.0 31.9	32.0 34.9	35.0 37.9	38.0 39.8	16.6 39.8	
10.0 12.9	SMPLS. CATCH	0	0	0	0	0	0	1	1	0	2
	MIN-MAX							0.000	0.000		0.000
	MEAN										
13.0 15.9	SMPLS. CATCH	1	0	0	2	1	7	6	1	0	18
	MIN-MAX	200.000			125.500	0.000	2.000	140.333	5.000		72.000
	MEAN	112- 180 141.4			96- 182 140.9		90- 167 115.2	97- 187 131.3	80- 111 103.2		80- 187 134.6
16.0 18.9	SMPLS. CATCH	0	0	1	0	0	1	7	13	2	24
	MIN-MAX			8.000			0.000	71.285	128.230	8.000	91.250
	MEAN			114- 162 130.7				90- 195 117.5	98- 246 133.6	107- 127 115.2	90- 246 130.7
19.0 21.9	SMPLS. CATCH	0	1	0	3	0	0	5	6	0	15
	MIN-MAX		12.000		183.333			1.000	58.000		61.000
	MEAN		114- 161 131.5		100- 195 131.2			53- 117 76.4	98- 190 135.0		53- 195 132.1
22.0 24.9	SMPLS. CATCH	0	0	0	1	0	0	0	0	0	1
	MIN-MAX				0.000						0.000
	MEAN										
25.0 27.9	SMPLS. CATCH	0	0	0	0	0	0	0	0	0	0
	MIN-MAX										
	MEAN										
28.0 29.5	SMPLS. CATCH	0	0	0	0	0	0	0	0	0	0
	MIN-MAX										
	MEAN										
10.8 29.5	SMPLS. CATCH	1	1	1	6	1	8	19	21	2	60
	MIN-MAX	200.000	12.000	8.000	133.500	0.000	1.750	70.842	98.190	8.000	73.616
	MEAN	112- 180 141.4	114- 161 131.5	114- 162 130.7	96- 195 134.5		90- 167 115.2	53- 195 126.0	80- 246 133.7	107- 127 115.2	53- 246 132.1

Specimens were taken at salinities ranging from 16.6 to 39.8 ppt. A salinity preference in this range was not apparent in our data (Table 27).

Sizes ranged from 53 to 256 mm TL, with small and large fish occurring together during all months. The largest individuals appeared from March through June. A spawning period in the spring has been suggested by Hildebrand (1954) and Miller (1965).

Roithmayr (1965) listed *S. caprinus* as the sixth most important species in the northern Gulf industrial bottom fishery. Our records show an approximate total mass of 1,337 kg, second in order of total weight.

Longspine porgies were not taken in GMEI samples but we have

scarcity of this species in the Gulf during warmer months with the exception of single collections in August and September. Their September collection was in 254 fathoms (465 meters) while all others were taken in depths varying from 6 to 37 fathoms (11 to 68 meters).

The specimens we collected measured from 62 to 255 mm TL. The temperatures of collections varied from 13.5° to 28.0°C and salinities from 23.8 to 38.6 ppt. Gunter (1945) noted that this fish prefers salinities over 30.0 ppt. Our findings concur with his. The majority of our collections were taken in salinities above 32.0 ppt.

Smaller fishes ranging 62 to 96 mm TL were taken during all months in which the species occurred. Hildebrand and Cable (1938) reported that spadefish spawn offshore in the summer in the Beaufort, North Carolina, area. Reid (1954) mentioned that this species probably spawns in the spring around Cedar Key, Florida.

Spadefish (17 to 229 mm TL) were taken in GMEI samples in all salinity ranges above 10 ppt with a maximum catch per unit of effort in the 20 to 24.9 ppt interval.

The spadefish is an excellent panfish. They often concentrate around anchored boats and buoys.

TRICHIURIDAE - Cutlass fishes

Trichiurus lepturus Linnaeus - Atlantic cutlass fish

A total of 172 individuals was taken in all months with peak numbers in the winter and spring months. Total length range was 175 to 820 mm. Temperatures ranged 13.0° to 27.3°C and salinities 24.9 to 37.7 ppt. The smallest individuals were obtained in November and January. These are probably the product of spring spawning as inferred by Miller (1965). Dawson (1967) and Miller (1965) collected very young fish in May and June (under 127 mm), and Dawson (1967) found larvae averaging 9.5 mm mean length in late April in plankton samples.

Roithmayr (1965) lists this fish as contributing 5% by weight of the total catch of industrial bottomfishes in the north-central Gulf in 1959 to 1963.

Our catch per unit of effort for this species was much higher in day sampling during 1967 and 1968; however, a reversal was found for Stations 4, 5 and 6 in 1969. Dawson (1967) took only 0.6% of his specimens during night trawling and explained that *T. lepturus* is known to feed at the surface at night. He took 11,388 cutlass fish in 188 hauls off Grand Isle, Louisiana.

We have observed dense schools of young cutlass fish in Mississippi Sound and adjacent waters. This was one of the 20 most abundant fishes in GMEI samples. Observed total length in the estuarine study area was 32 to 707 mm.

SCOMBRIDAE - Mackerels and tunas

Scomber colias Gmelin - Chub mackerel

This species appeared only in 1968 and 1969. Fifty-six were taken in 1968 at temperatures and salinities ranging between 21.0° and 24.0° C and from 27.0 to 27.8 ppt. A length range of 81 to 229 mm TL was noted for these specimens. One chub mackerel (229 mm TL) was taken at 40 fathoms in March 1969. The temperature and salinity at the time were 16.9° C and 35.7 ppt. Hildebrand (1954) examined an individual (23 mm TL) taken in April from 33 to 49 fathoms (60 to 90 meters) and remarked that the ovaries appeared to be almost ripe. The species is uncommonly reported in the literature concerning the northern Gulf.

We have taken early juvenile *Scomber colias* with seine hauls from grass beds around Horn Island in the spring, but they did not appear in GMEI samples.

Scomberomorus maculatus (Mitchill) - Spanish mackerel

Eight spanish mackerel were taken, 5 in 1967 (5 and 10 fathoms) and 3 in 1968 (10 fathoms). Specimens measured 177 to 297 mm TL with a total mass of 1.034 kg. Mackerel were collected at temperatures between 19.4° and 28.9° C and salinities between 31.6 to 37.4 ppt. Numerous schools of *S. maculatus* were observed on several occasions offshore.

Large schools of Spanish mackerel have been found near the Mississippi offshore barrier island passes during the summer. We have also observed numerous schools of small Spanish mackerel in the Sound. A few specimens were caught in GMEI samples.

This species usually appears in Mississippi waters in April and remains until late fall. Sports fishermen take large numbers of this species. Commercial fishermen only incidentally take Spanish mackerel. Although the extent of this resource is not known the supply seems to be adequate to support a commercial fishery.

GOBIIDAE - Gobies

Bollmannia communis Ginsburg

Sixteen specimens of *B. communis* were collected. Four fish taken in 1967 and eleven in 1968 (all from 5 and 20 fathoms) were collected at temperatures and salinities of 16.5° to 29.5°C and 24.6 to 36.5 ppt respectively. Only one of the 1967 specimens was measured (75 mm TL in March), and only one in 1968 (90 mm TL in June). The remaining specimens were damaged enough to prevent a proper TL measurement from being recorded.

Hildebrand (1954) took 770 specimens from the deep-water brown shrimp grounds. Miller (1965) found 22 fish; 21 were from 15 fathoms and one from 12 fathoms.

SCORPAENIDAE - Scorpionfishes and rockfishes

Neomerinthe pollux (Poey) - Spiny cheek scorpionfish

One individual, 388 mm TL and 453 grams in weight, was taken in May 1967 at Station 6. The temperature was 18.6°C, and the salinity was 35.0 ppt. This species is rarely reported from the northern Gulf.

Pontinus longispinis Goode and Bean - Scalyhead scorpionfish

Seven specimens (72 to 90 mm TL) were collected in March 1967 at Station 6. Temperature and salinity were recorded at 20.0°C and 37.8 ppt. This species did not recur in subsequent samples.

Scorpaena calcarata Goode and Bean - Smoothhead scorpionfish

A total of 205 specimens (57 to 273 mm TL) were collected in 48 samples. A temperature and salinity minima and maxima were recorded at 14.1° and 27.0°C and 16.6 and 39.8 ppt. Catch per haul was highest at 30 fathoms where 50% of all hauls included this species. These hauls took 57% of the total number. Gunter (1948) reported this to be the most abundant scorpaenid in the shallow Gulf.

Smoothhead scorpionfish were collected in all months except January at Station 4. At Station 3 they were not collected from June through October and the one specimen from Station 2 was taken in February. They were not found in Station 5 samples from October through February.

Total lengths less than 90 mm were recorded throughout the year and 94% of these measurements were between 57 and 109 mm. All of the 12 specimens over 180 mm TL were collected in the period February through May.

TRIGLIDAE - Searobins

Bellator militaris (Goode and Bean) - Horned searobin

This species was represented by sixty-seven specimens (ranging from 67 to 113 mm TL). Moe and Martin (1965) collected one specimen, and other surveys have not reported *B. militaris* as being common in the northern Gulf. Specimens were taken no shallower than 30 fathoms with temperatures and salinities between 14.1° and 25.2°C and 16.6 to 37.4 ppt respectively.

Peristedion gracile Goode and Bean

A total of six specimens was collected in March 1967 at Stations 4, 5 and 6. The temperature range for these fish was 19.0° to 20.0°C, and salinities were recorded between 36.2 and 37.8 ppt. The Station 4 individual was 168 mm TL and weighed 30.3 grams. Two fish from Station 5 measured 159 and 165 mm TL, and weighed 20.4 and 26.5 grams, respectively. Three specimens were collected at 50 fathoms and ranged in length from 166 to 190 mm TL and from 30.0 to 44.3 grams in weight.

Prionotus alatus Goode and Bean - Spiny searobin

Three specimens were taken in one haul from 50 fathoms in May 1967. Specimens were 110, 111 and 113 mm TL and were taken at a temperature of 20.0°C and a salinity of 37.8 ppt.

Prionotus ophryas Jordan and Swain - Bandtail searobin

A single specimen of *P. ophryas* was collected from 50 fathoms in March 1967. The fish measured 160 mm TL and weighed 57.8 g. The temperature was 20.0°C and the salinity was 37.8 ppt.

Prionotus paralatus Ginsburg - Mexican searobin

This species of searobin was taken only in 1967 and only during January (1 specimen, 156 mm TL) and March (33 specimens, 117 to 184 mm TL). The first specimen occurred at a temperature of 18.6°C and a salinity of 36.9 ppt at Station 4. March specimens were taken at temperatures and salinities ranging between 18.6° to 20.0°C and 36.2 to 37.8 ppt respectively.

Prionotus pectoralis Nichols and Breder - Blackwing searobin

A total of 22 blackwing searobins was taken in 1967 at Station 4. Specimens taken in March (10) ranged from 156 to 201 mm TL, and those in June (12) ranged from 155 to 204 mm TL. All fish were

collected within a temperature and salinity range of 20.0° to 20.4°C and 36.7 to 37.8 ppt.

Prionotus roseus Jordan and Evermann - Bluespotted searobin

This species was represented by nine specimens. In November 1967 one specimen (176 mm TL and 54.0 g) appeared in a night haul at 30 fathoms. The remaining eight specimens were taken in 1968 and ranged from 107 to 186 mm TL. These fish were collected in waters with temperatures and salinities ranging from 15.2° to 22.0°C and 23.2 to 37.0 ppt respectively. *Prionotus roseus* was not listed by Roithmayr (1965).

Prionotus rubio Jordan - Blackfin searobin

The majority of the specimens (877) of this species were found deeper than 10 fathoms. Hildebrand (1954) found numerous specimens and noted that this species prefers deep waters. Our fish ranged from 68 to 328 mm TL. Miller (1965) found indications of a fall and winter spawning period. Temperatures and salinities ranged from 14.0° to 29.0°C and from 16.6 to 39.8 ppt.

Prionotus scitulus Jordan and Gilbert - Leopard searobin

Forty-seven leopard searobins were taken. They were obtained in all months with August being the peak month of capture. The temperatures ranged from 14.2° to 28.0°C, and the salinities varied from 24.9 to 37.2 ppt. The majority of specimens were taken at salinities above 32.0 ppt. The length range was 72 to 230 mm TL. Moe and Martin (1965) reported that the majority of their specimens came from depths of 25 to 45 feet. Our specimens were fairly evenly distributed from 5 to 30 fathoms. Moe and Martin (1965) collected their smallest specimens in February and March; ours were obtained in March and December.

GMEI samples at higher salinities included *P. scitulus*.

Prionotus stearnsi Jordan and Swain - Shortwing searobin

Seventeen *P. stearnsi* appeared in the three years of sampling at temperatures and salinities of 16.1° to 20.5°C and 33.5 to 37.4 ppt respectively. A size of 79 to 134 mm TL was noted for these individuals. Roithmayr (1965) does not list *P. stearnsi* as occurring in the industrial bottomfish hauls; however, Oregon hauls in the Gulf have taken this species.

Prionotus tribulus Cuvier - Bighead searobin

Thirty-five individuals of this species were obtained in all months except April, October and December. These specimens were 49 to 285 mm TL. The temperatures ranged from 14.3° to 28.9°C and salinities from 29.3 to 36.8 ppt.

The smallest specimen was taken in February. Gunter (1956) collected small individuals in March and April in Texas; however, Springer and Woodburn (1960) found that young appeared in late fall and winter in the Tampa Bay area of Florida. Hildebrand (1954) found a nearly ripe female in August on the Obregon shrimp grounds. Miller (1965) took small specimens in February and June. Moe and Martin (1965) also took small specimens in February and March.

Moe and Martin (1965), Hildebrand (1954) and Miller (1965) noted that this species prefers shallower waters. Our data show indications of this also, with the majority of specimens being taken from 5 to 20 fathoms. This was far and away the most common searobin taken by Gunter (1945) in Texas waters. He did not fish in waters deeper than 10 fathoms.

This was the most abundant searobin in GMEI samples.

URANOSCOPIDAE

Astroscopus y-graecum (Cuvier) - Southern stargazer

A single specimen of the southern stargazer was collected in January 1968 at 50 fathoms. The fish measured 210 mm TL and weighed 152.9 grams. Temperature and salinity at this time were 15.1°C and 26.2 ppt.

The southern stargazer was collected in numerous GMEI samples, and early juveniles were evident in fall and winter hauls.

Uranoscopus sp.

An unidentified specimen of *Uranoscopus* was taken in March 1967 in 30 fathoms at a temperature of 20.0°C and a salinity of 36.7 ppt. The fish measured 119 mm TL and weighed 33.5 grams. This specimen was deposited in the Gulf Coast Research Laboratory museum.

Kathetostoma albigutta (Bean) - Lancer stargazer

Twelve *Kathetostoma albigutta* were taken during the three years at temperatures between 14.1° and 25.5°C and salinities between 16.6 and 37.2 ppt. Specimens measured 106 to 165 mm TL.

BROTULIDAE - Brotulas

Brotula barbata (Block and Schneider) - Bearded brotula

Three *B. barbata* were collected in 1967, ten in 1968 and one in 1969. Specimens ranged from 197 to 414 mm TL in 1967 and 1968. They were collected at temperatures and salinities ranging between 15.3° to 22.4° C, and 33.2 to 37.4 ppt respectively and at 20, 40 and 50 fathoms.

The 1969 specimen was 565 mm TL and weighed 1,814.4 grams. Capture of this fish came at 50 fathoms in January at a temperature of 16.8° C and a salinity of 36.5 ppt.

Miller (1965) took two in Texas. We have taken numerous specimens of small *B. barbata* in less than ten fathoms around Horn Island, Mississippi.

OPHIDIIDAE - Cusk-eels

Lepophidium graellsii (Poey) - Cusk-eel

Our samples included 277 *L. graellsii*. This species was collected from all stations. Sizes ranged from 69 to 290 mm TL, and specimens were collected at temperatures from 14.3° to 28.9° C and salinities from 19.9 to 39.8 ppt.

Ophidion welshi (Nichols and Breder) - Crested cusk-eel

Thirty specimens were taken at a temperature range of 14.0° to 28.0° C, and a salinity range of 25.7 to 37.4 ppt. A size range of 107 to 215 mm TL was noted for these individuals. The majority of specimens taken in this study were from 5 fathoms with a few from 10 and 20 fathoms.

Miller (1965) indicated that *O. welshi* was more likely to be found at less than a 6-fathom depth. Great abundance has not been reported.

GMEI samples took 24 crested cusk-eels in 484 trawl samples. Total length range in the estuarine study area was 25 to 183 mm. All specimens less than 100 mm TL were found in salinity less than 30 ppt.

STROMATEIDAE - Butterfishes

Peprilus alepidotus (Linnaeus) - Northern harvestfish

A total of forty-two northern harvestfish was taken with 98% being taken in winter and spring months. Miller (1965) collected the

majority of his specimens in June. Gunter (1945) collected *P. paru* in August, January and March in the Gulf at temperatures ranging from 13.7° to 30.0°C and salinities ranging from 33.0 to 36.7 ppt. Our data shows a temperature range of 14.2° to 21.5°C and a salinity range of 26.2 to 37.4 ppt. Specimens measured from 90 to 227 mm TL.

Peprilus burti Fowler - Butterfish

Caldwell (1961) places *P. burti* Fowler in the synonymy of *P. triacanthus* (Peck). Specimens were taken in all months and at all stations with the greatest numbers being found at 10 and 50 fathoms. A total of 7,016 fish were collected, and this number represents 7.49% of the total fish catch. The greatest numbers were taken in April and May with other sizeable catches appearing in June, August, October and January.

The greatest catch per unit of effort in 1967 occurred at the 10-fathom depth, and the 30-fathom station showed only slightly less. In 1968 the greatest CPUE, which far surpassed that from other depths, occurred at 50 fathoms. The 5-fathom station showed the greatest catch per unit of effort in 1969. The largest CPUE from 50 fathoms was associated with a mean temperature and salinity of 19.9°C and 34.4 ppt respectively. A comparison of day and night hauls shows a much higher CPUE during the day for all stations. Hildebrand (1954) noted this for his hauls by remarking that greater catches occurred during "the early morning and day-time drags." Springer and Bullis (1952) noted captures of this species with midwater trawls, and Caldwell (1961) noted that butterfish may school at the surface, near midwater, or at the bottom.

This species occurred at salinities ranging from 16.6 to 39.8 ppt. Gunter (1945) found a salinity range of 15.6 to 35.2 ppt for *Peprilus* with the majority of specimens appearing at salinities greater than 30.0 ppt. Both a preference for salinities in the range 23.0 to 37.9 ppt with the largest catch per unit of effort at 26.0 to 38.9 ppt are shown in Table 28. Temperatures ranged from 10.8° to 29.5°C. Gunter (1945) found this fish at a temperature range of 12.6° to 28.0°C and Miller (1965) noted temperatures of 12.8° to 25.7°C when catches were made.

Specimens taken ranged from 24 to 240 mm TL, and small fish were taken with large ones in all months.

In GMEI samples butterfish were fifth in numbers of fishes caught by seines and trawls. Their total lengths were from 17 to 171 mm.

Phillips, Burke and Keener (1969) discussed the association of young butterfish with coelenterates. We have observed this

TABLE 28
DISTRIBUTION OF *PEPRILUS BURTI* BY BOTTOM SALINITY AND
TEMPERATURE INTERVALS SHOWING NUMBER OF SAMPLES, CATCH PER
UNIT OF EFFORT, MINIMUM, MAXIMUM AND MEAN TOTAL LENGTH (MM).

		1967									
		SALINITY INTERVAL PPT									
TEMP INT. C		16.6 16.9	17.0 19.9	20.0 22.9	23.0 25.9	26.0 28.9	29.0 31.9	32.0 34.9	35.0 37.9	38.0 39.8	16.6 39.8
	SMPLS.	0	0	0	0	0	0	0	0	0	0
10.8	CATCH										
12.9	MIN-MAX										
	MEAN										
	SMPLS.	0	0	0	0	0	1	6	1	0	8
13.0	CATCH						18.000	115.166	0.000		88.625
15.9	MIN-MAX						54- 73	49- 104			49- 104
	MEAN						59.7	81.1			79.7
	SMPLS.	0	0	0	0	1	1	4	13	0	19
16.0	CATCH					2.000	0.000	7.500	92.846		65.210
18.9	MIN-MAX					144- 157		38- 88	66- 205		38- 205
	MEAN					150.5		61.8	89.2		84.9
	SMPLS.	0	0	0	0	0	2	4	21	0	27*
19.0	CATCH						2.000	2.500	2.619		2.555
21.9	MIN-MAX						95- 140	127- 165	103- 209		95- 209
	MEAN						121.7	150.6	162.0		158.0
	SMPLS.	0	0	0	0	0	1	1	12	0	14
22.0	CATCH						46.000	0.000	17.833		18.571
24.9	MIN-MAX						75- 137		110- 210		75- 210
	MEAN						114.6		152.2		140.9
	SMPLS.	0	0	0	0	0	4	2	18	0	24
25.0	CATCH						12.500	13.500	34.611		29.166
27.9	MIN-MAX						112- 188	112- 160	105- 207		105- 207
	MEAN						153.3	140.7	151.3		150.7
	SMPLS.	0	0	0	0	0	0	2	0	0	2
28.0	CATCH							10.000			10.000
29.5	MIN-MAX							127- 229			127- 229
	MEAN							160.2			160.2
	SMPLS.	0	0	0	0	1	9	19	65	0	94
10.8	CATCH					2.000	13.111	40.947	32.292		31.882
29.5	MIN-MAX					144- 157	54- 188	38- 229	66- 210		38- 229
	MEAN					150.5	127.4	96.5	139.0		126.2

		1968									
		SALINITY INTERVAL PPT									
TEMP INT. C		16.6 16.9	17.0 19.9	20.0 22.9	23.0 25.9	26.0 28.9	29.0 31.9	32.0 34.9	35.0 37.9	38.0 39.8	16.6 39.8
	SMPLS.	0	0	0	0	0	0	0	0	0	0
10.8	CATCH										
12.9	MIN-MAX										
	MEAN										
	SMPLS.	0	0	0	1	4	0	6	0	0	11
13.0	CATCH				9.000	0.500		3.000			2.636
15.9	MIN-MAX				120- 157	143- 153		108- 231			108- 231
	MEAN				144.2	148.0		129.9			135.6
	SMPLS.	0	0	0	2	2	3	6	8	0	21
16.0	CATCH				1.000	2.500	0.000	0.666	3.000		1.666
18.9	MIN-MAX				174- 205	142- 160		169- 205	117- 203		117- 205
	MEAN				189.5	150.4		186.0	155.3		160.1
	SMPLS.	0	0	0	3	8	3	8	5	1	28
19.0	CATCH				0.333	300.125	0.000	98.750	1.200	0.000	114.214
21.9	MIN-MAX				209- 209	61- 193		24- 198	103- 137		24- 209
	MEAN				209.0	102.8		149.2	121.1		122.2
	SMPLS.	0	0	0	0	2	0	2	4	0	8
22.0	CATCH					18.500		0.000	3.000		6.125
24.9	MIN-MAX					61- 240			102- 166		61- 240
	MEAN					148.5			135.0		145.3
	SMPLS.	0	0	0	1	1	3	1	6	3	15
25.0	CATCH				0.000	8.000	21.000	0.000	7.666	4.000	8.600
27.9	MIN-MAX					87- 127	71- 195		111- 193	92- 132	71- 195
	MEAN					113.6	127.9		140.1	112.2	130.3
	SMPLS.	0	1	0	0	2	3	1	1	0	8
28.0	CATCH		0.000			10.500	3.333	5.000	0.000		4.500
29.5	MIN-MAX					81- 155	78- 128	81- 106			78- 155
	MEAN					112.4	97.7	93.6			106.2
	SMPLS.	0	1	0	0	7	19	12	24	4	91
10.8	CATCH		0.000			1.714	130.210	6.083	34.041	3.666	38.197
29.5	MIN-MAX					120- 209	61- 240	71- 195	24- 231	102- 203	92- 132
	MEAN					157.1	108.4	123.2	147.4	142.3	125.9

TABLE 28 (Continued)
1969

TEMP INT. C	SALINITY INTERVAL PPT									
	16.6 16.9	17.0 19.9	20.0 22.9	23.0 25.9	26.0 28.9	29.0 31.9	32.0 34.9	35.0 37.9	38.0 39.8	38.6 39.8
SMPLS. 10.8 CATCH	0	0	0	0	0	0	1	1	0	2
12.9 MIN-MAX							9.000	2.000		5.500
MEAN							100- 111	125- 153	100-	153
							107.0	139.0		112.0
SMPLS. 13.0 CATCH	1	0	0	2	1	7	6	1	0	18
15.9 MIN-MAX	5.000			2.500	14.000	4.714	1.500	0.000		3.666
MEAN	156- 208			198- 216	94- 140	65- 185	70- 210			65- 216
	169.0			205.8	127.5	154.6	174.7			156.6
SMPLS. 16.0 CATCH	0	0	1	0	0	1	7	13	2	24
18.9 MIN-MAX			0.000			0.000	2.142	2.615	9.000	2.791
MEAN							158- 219	179- 221	170- 215	158- 221
							183.8	196.4	194.3	193.0
SMPLS. 19.0 CATCH	0	1	0	3	0	0	5	6	0	15
21.9 MIN-MAX		0.000		109.000			9.000	3.333		26.133
MEAN				91- 196			88- 158	85- 205		85- 205
				116.8			120.0	124.6		118.6
SMPLS. 22.0 CATCH	0	0	0	1	0	0	0	0	0	1
24.9 MIN-MAX				0.000						0.000
MEAN										
SMPLS. 25.0 CATCH	0	0	0	0	0	0	0	0	0	0
27.9 MIN-MAX										
MEAN										
SMPLS. 28.0 CATCH	0	0	0	0	0	0	0	0	0	0
29.5 MIN-MAX										
MEAN										
SMPLS. 10.8 CATCH	1	1	1	6	1	8	19	21	2	60
12.9 MIN-MAX	5.000	0.000	0.000	55.333	14.000	4.125	4.105	2.666	9.000	8.933
MEAN	156- 208			91- 216	94- 140	65- 185	70- 219	85- 221	170- 215	65- 221
	169.0			121.0	127.5	154.6	137.1	168.7	194.3	142.6

phenomenon many times. Apparently this species utilizes jellyfish for food.

The occurrence of young fish in winter and spring hauls prompted Miller (1965) to suggest an early winter and possibly a fall spawning period.

This species was listed by Roithmayr (1965) as a component of the industrial bottomfish catches. Our catch showed an approximate total weight of 1,891.6 kg, sixth in order of total weight.

Although butterfish comprise an important part of Chesapeake food fish, they have not been harvested in the Gulf because of their smaller size in Gulf waters. Larger specimens taken in our samples proved to be an excellent pan fish.

SPHYRAENIDAE - Barracudas

Sphyraena gauchancho Cuvier - Guaguanche

Eight guaguanche were captured, five in 1967 (5 and 30 fathoms) and three in 1968 (5, 10 and 40 fathoms). The smallest specimen, 148 mm TL, appeared in November and the largest individual, 345 mm TL,

was taken in December. Fish were collected at temperatures and salinities ranging from 14.4° to 24.2°C and 26.6 to 37.0 ppt respectively.

MUGILIDAE - Mullet

Mugil cephalus Linnaeus - Striped mullet

One specimen of the striped mullet was collected in November 1968 at 30 fathoms. This fish measured 355 mm TL and weighed 375.0 grams. Temperature and salinity readings of 16.4°C and 37.4 ppt were recorded.

The striped mullet is generally an inshore species; however, spawning is accomplished in the deeper offshore waters. Gunter (1945) stated that spawning occurred in the Gulf near passes through outside beaches. Broadhead (1953) inferred that spawning takes place at 5 to 20 fathoms. Arnold and Thompson (1958) observed spawning striped mullet at the surface of 775 fathoms of water off the Mississippi River delta.

POLYNEMIDAE - Threadfins

Polydactylus octonemus (Girard) - Threadfin

A threadfin measuring 183 mm TL and weighing 54.4 grams was collected at Station 1 in September 1967. The temperature and salinity at this time were 26.1°C and 31.6 ppt, respectively.

GMEI samples included 2 threadfins. Periodically, young threadfin appear in the study area in large numbers (fide Christmas).

PLEURONECTIFORMES

BOTHIDAE - Lefteye flounders

Ancylosetta dilecta (Goode and Bean) - Three-eye flounder

Three *A. dilecta* were encountered, one in each of the three years. In March 1967 at a temperature of 19.0°C and a salinity of 36.2 ppt, a 247 mm TL specimen weighing 129.2 grams was taken at 40 fathoms. At a temperature of 19.3°C and a salinity of 27.9 ppt, a 108 mm TL specimen weighing 13.9 grams was collected at 50 fathoms in October 1968. A 163 mm TL specimen weighing 43.5 grams was captured at 50 fathoms in May 1969 at a temperature and salinity of 20.5°C and 19.9 ppt. This species has been reported rarely from the Gulf.

Ancylosetta quadrocellata Gill - Ocellated flounder

Three ocellated flounders were taken, two in August of 1967 and one in January of 1968. The two August specimens measured 221 and 224 mm TL and weighed 150.6 and 163.0 grams, respectively. The 221 mm-specimen was taken at Station 1 at a temperature and salinity of 25.1°C and 35.8 ppt. Readings of 22.4°C and 36.5 ppt were recorded for the 224-mm specimen. In January 1968 a 320-mm-TL fish weighing 399.8 grams was collected at Station 1 at a temperature and salinity of 14.8°C and 28.5 ppt. Springer and Woodburn (1960) collected two individuals at salinities of 30.1 and 31.3 ppt and temperatures of 22.0° and 27.7°C. Gunter (1945) found the salinity range in Texas waters to be 22.8 - 36.7.

Ancylosetta quadrocellata is known to occur in shallow water in bays and offshore to depths of 80 fathoms (Springer and Bullis 1956).

A spawning period in winter has been suggested (Joseph and Yerger 1956, Hildebrand 1955).

GMEI samples included ocellated flounders from a wide range of salinity.

Citharichthys macrops Dresel - Spotted whiff

Four *C. macrops* were taken in one haul at 10 fathoms in June 1967. This is the total catch of this species. Sizes ranged from 133 to 148 mm TL with a total weight of 121 grams. The temperature and salinity at the time of capture were 25.0°C and 35.1 ppt. Gunter (1945) only took two off the Texas Coast. Springer and Bullis (1956) found *C. macrops* to be somewhat common at depths to 37 fathoms. This species apparently is not a regular component of trawl hauls, and its distribution is not clearly established.

Citharichthys spilopterus Günther - Bay whiff

Fifty-five specimens (69 to 198 mm TL) were taken with the majority of specimens being collected at 10 and 20 fathoms. These fish were taken at temperatures and salinities between 14.9° to 29.0°C and 25.7 to 37.4 ppt from June through February. Gunter (1945) said there was apparently a winter movement offshore and Hildebrand (1954) noted a similar occurrence in his catches. The bay whiff was the second most abundant flatfish in GMEI samples. Fish were found in the estuarine study area from April through November and included total lengths from 18 to 125 mm. The late fall migration from the estuarine study area is clear but is not reflected in our samples. No specimens were taken in either area during March.

The 198 mm TL specimen collected at 50 fathoms in October weighed 58.8 grams. This is a very large northern Gulf bay whiff. Meek and Hildebrand (1928) considered their 170-mm specimen to be large for the species.

Cyclopsetta chittendeni Bean - Mexican flounder

A total of 375 Mexican flounders were taken. This species was represented in all months and was found at depths of 10 to 50 fathoms with the greatest number taken at 20 fathoms. The temperatures and salinities at which this species was encountered varied from 14.9° to 28.9°C and from 19.8 to 39.8 ppt respectively (Table 29). The sizes ranged from 68 to 335 mm TL.

We took our smallest individual (68 mm) in August. Dawson (1968) also encountered fish of this approximate size in August. This species is considered quite common in offshore waters (Gunter and Knapp 1951). Hildebrand (1954), noted that larger fish of this species prefer depths over 20 fathoms, whereas, younger individuals are found at depths of 12 to 20 fathoms. Dawson (1968) took this flounder at depths of 11 to 20 fathoms off Grand Isle, Louisiana with the majority being taken at 20 fathoms. Our data shows this depth preference.

TABLE 29
DISTRIBUTION OF *CYCLOPSETTA CHITTENDENI* BY BOTTOM SALINITY AND TEMPERATURE INTERVALS SHOWING NUMBER OF SAMPLES, CATCH PER UNIT OF EFFORT, MINIMUM, MAXIMUM AND MEAN TOTAL LENGTH (MM).

		1967									
		SALINITY INTERVAL PPT									
TEMP		16.6	17.0	20.0	23.0	26.0	29.0	32.0	35.0	38.0	16.6
INT.		16.9	19.9	22.9	25.9	28.9	31.9	34.9	37.9	39.8	39.8
	SMPLS.	0	0	0	0	0	0	0	0	0	0
10.8	CATCH										
12.9	MIN-MAX										
	MEAN										
	SMPLS.	0	0	0	0	0	1	6	1	0	8
13.0	CATCH						0.000	1.066	0.000		1.250
15.9	MIN-MAX							123- 335			123- 335
	MEAN							209.8			209.8
	SMPLS.	0	0	0	0	1	1	4	13	0	19
16.0	CATCH					0.000	0.000	0.000	2.384		1.631
18.9	MIN-MAX								117- 245		117- 245
	MEAN								164.3		164.3
	SMPLS.	0	0	0	0	0	2	4	21	0	27
19.0	CATCH						0.000	0.250	3.095		2.444
21.9	MIN-MAX							153- 153	80- 263		80- 263
	MEAN							153.0	169.5		169.2
	SMPLS.	0	0	0	0	0	1	1	12	0	14
22.0	CATCH						0.000	0.000	1.666		1.428
24.9	MIN-MAX								68- 261		68- 261
	MEAN								191.0		191.0
	SMPLS.	0	0	0	0	0	4	2	18	0	24
25.0	CATCH						0.000	1.000	1.388		1.125
27.9	MIN-MAX							185- 209	85- 247		85- 247
	MEAN							197.0	184.8		185.7
	SMPLS.	0	0	0	0	0	0	2	0	0	2
28.0	CATCH							6.000			6.000
29.5	MIN-MAX							92- 122			92- 122
	MEAN							108.6			108.6
	SMPLS.	0	0	0	0	1	9	19	69	0	94
10.8	CATCH					0.000	0.000	1.315	2.169		1.765
29.5	MIN-MAX							92- 335	68- 263		68- 335
	MEAN							157.9	174.1		171.7

NEKTONIC AND BENTHIC FAUNAS

TABLE 29 (Continued)
1968

TEMP INT. C	SALINITY INTERVAL PPT									
	16.6 16.9	17.0 19.9	20.0 22.9	23.0 25.9	26.0 28.9	29.0 31.9	32.0 34.9	35.0 37.9	38.0 39.8	39.6
SMPLS. 10.8 CATCH 12.9 MIN-MAX MEAN	0	0	0	0	0	0	0	0	0	0
SMPLS. 13.0 CATCH 15.9 MIN-MAX MEAN	0	0	0	1 0.000	4 0.000	0	6 0.853 116- 247 177.8	0	0	11 0.454 116- 247 177.8
SMPLS. 16.0 CATCH 18.9 MIN-MAX MEAN	0	0	0	2 16.500 126- 232 169.1	2 0.000	3 24.666 113- 199 154.6	6 0.333 170- 202 186.0	8 0.750 220- 263 237.8	0	21 5.476 113- 263 163.6
SMPLS. 19.0 CATCH 21.9 MIN-MAX MEAN	0	0	0	3 0.000	8 0.250 263- 266 264.5	3 0.000	8 1.625 205- 250 226.5	5 2.000 205- 273 247.0	1 1.000 222- 222 222.0	28 0.928 205- 273 237.1
SMPLS. 22.0 CATCH 24.9 MIN-MAX MEAN	0	0	0	0	2 0.000	0	2 4.000 171- 227 193.3	4 2.000 205- 280 234.5	0	8 2.000 171- 280 213.9
SMPLS. 25.0 CATCH 27.9 MIN-MAX MEAN	0	0	0	1 0.000	1 0.000	3 0.333 240- 246 246.0	1 0.000	6 0.500 169- 201 184.3	3 0.000	15 0.266 169- 246 199.7
SMPLS. 28.0 CATCH 29.5 MIN-MAX MEAN	0	1 0.000	0	0	2 0.000	3 0.000	1 0.000	1 1.000 192- 192 192.0	0	8 0.125 192- 192 192.0
SMPLS. 10.8 CATCH 29.5 MIN-MAX MEAN	0	1 0.000	0	7 4.714 126- 232 169.1	19 0.105 263- 266 264.5	12 0.250 113- 246 155.8	24 1.166 116- 250 205.4	24 1.166 169- 280 232.7	4 0.250 222- 222 222.0	91 1.835 113- 280 181.3

1969

TEMP INT. C	SALINITY INTERVAL PPT									
	16.6 16.9	17.0 19.9	20.0 22.9	23.0 25.9	26.0 28.9	29.0 31.9	32.0 34.9	35.0 37.9	38.0 39.8	39.6
SMPLS. 10.8 CATCH 12.9 MIN-MAX MEAN	0	0	0	0	0	0	1 0.000	1 0.000	0	2 0.000
SMPLS. 13.0 CATCH 15.9 MIN-MAX MEAN	1 0.000	0	0	2 0.000	1 0.000	1 0.428 139- 170 151.3	6 0.000	1 4.000 134- 259 172.5	0	18 0.388 134- 259 163.4
SMPLS. 16.0 CATCH 18.9 MIN-MAX MEAN	0	0	1 0.000	0	0	1 2.000 126- 242 184.0	7 1.142 172- 280 236.0	13 1.615 205- 280 240.5	2 0.500 158- 158 158.0	24 1.333 126- 280 233.3
SMPLS. 19.0 CATCH 21.9 MIN-MAX MEAN	0	1 1.000 290- 290 290.0	0	3 0.000	0	0	5 0.000	6 0.333 239- 240 239.5	0	15 0.200 239- 290 256.3
SMPLS. 22.0 CATCH 24.9 MIN-MAX MEAN	0	0	0	1 0.000	0	0	0	0	0	1 0.000
SMPLS. 25.0 CATCH 27.9 MIN-MAX MEAN	0	0	0	0	0	0	0	0	0	0
SMPLS. 28.0 CATCH 29.5 MIN-MAX MEAN	0	0	0	0	0	0	0	0	0	0
SMPLS. 10.8 CATCH 29.5 MIN-MAX MEAN	1 0.000	1 1.000 290- 290 290.0	1 0.000	6 0.000	1 0.000	8 0.625 126- 242 164.4	19 0.421 172- 280 236.0	21 1.285 134- 280 230.4	2 0.500 158- 158 158.0	80 0.700 126- 290 223.3

Engyophrys sentus Ginsburg - Spiny flounder

Two spring flounders were taken in 1968 (20 and 40 fathoms). A March specimen measured 73 mm TL and weighed 3.0 grams. A November specimen measured 87 mm TL and its weight was recorded as 7.0 grams. The March temperature and salinity were 17.0°C and 24.6 ppt. The temperature in November was 21.6°C and the salinity was 38.2 ppt. This species has been considered to be rare in Texas (Gunter and Knapp 1951). Hildebrand (1954) found *E. sentus* to be common at 15 fathoms and deeper. This species has been reported from 65 fathoms (Longley and Hildebrand 1941). Anderson and Lindner (1941) recorded 28 specimens from 25 to 40 fathoms. The distribution is relatively unknown.

Etropus crossotus Jordan and Gilbert - Fringed flounder

Three hundred forty-five *E. crossotus* were taken with all specimens ranging from 54 to 205 mm TL. They were collected at temperatures and salinities between 13.3° to 29.0°C and 23.2 to 39.8 ppt. *Etropus crossotus* was found at all stations and during all months. The majority of fish were taken from 5 to 30 fathoms.

Spawning occurs offshore from approximately March through June (Reid 1954; Moe and Martin 1965). Our largest individuals (205 and 204 mm TL) were collected in May and July, respectively. Gunter's (1945) data show offshore movement with the seasons, but they tell nothing of the far offshore distribution as presented here.

GMEI samples included *E. crossotus* (15 to 130 mm TL) in all months.

Paralichthys albigutta Jordan and Gilbert - Gulf flounder

One Gulf flounder taken in June 1967 from Station 1 measured 169 mm in length and weighed 62.8 grams. The temperature was 26.1°C and the salinity was 29.3 ppt.

Miller (1965) took one specimen at 6 fathoms and two at 9 fathoms. Gunter (1945), Hildebrand (1954) and Miller (1965) attest to the scarcity of this flounder in the northwestern and western Gulf, and our data are in agreement with their findings. Springer and Woodburn (1960) and Joseph and Yerger (1956) found this species quite common on the Florida coast. The absence of the preferred bottom (sandy) for this species could be one cause for its small numbers. We have taken *P. albigutta* (including early juveniles, 30 mm, and adults), though never in abundance in miscellaneous trawl hauls around the offshore barrier islands.

Paralichthys lethostigma Jordan and Gilbert - Southern flounder

A total of 37 southern flounders was taken during the three years of sampling. The lengths ranged from 127 to 452 mm TL. Temperatures ranged from 13.3° to 28.0°C, and the salinities were from 19.9 to 37.9 ppt.

Gunter (1945) found this species in temperatures varying from 9.9° to 30.5°C and salinities from 2.0 to 26.2 ppt. Gunter (1945) further stated that this fish seems to prefer salinities below 25 ppt, at least in the sizes he examined (up to 490 mm). Gunter (1945) found southern flounder with developing roe in October, and Ginsburg (1952) agreed by stating that the fish spawns in late fall to early winter.

GMEI samples included 121 specimens (20 to 367 mm total length). They were taken in all seasons and throughout the salinity range.

The southern flounder is a favorite food fish. It is sought by both sports and commercial fishermen. Mississippi landings (69,000 pounds in 1965) probably reflect only a fraction of the flounders caught for food.

Paralichthys squamilentus Jordan and Gilbert - Broad flounder

Twelve specimens of the broad flounder were collected in our samples. They varied 200 to 456 mm TL and were encountered at temperatures ranging from 14.0° to 25.5°C and salinities ranging from 24.9 to 37.8 ppt; however, this species seemed to prefer salinities over 32.0 ppt. They were taken at Stations 4, 5 and 6.

Syacium gunteri Ginsburg - Shoal flounder

The shoal flounder was the most abundant flatfish in our samples. Gunter and Knapp (1951) also reported *S. gunteri* to be the most abundant flatfish on the brown shrimp grounds. This species was obtained during all months and at depths from 5 to 50 fathoms with the greatest numbers taken at 20 fathoms. Hildebrand (1954) and Miller (1965) took this fish in abundance, and Hildebrand (1954) mentioned it as being the most common fish on the brown shrimp grounds of the western Gulf. These authors also noted that this fish is more abundant at depths greater than 10 fathoms. Gunter (1945) took 192 individuals but found them only in the Gulf. Springer and Woodburn (1960) and Reid (1954) did not record this species, indicating this fish does not enter inshore waters near Florida.

The sizes encountered ranged from 72 to 270 mm TL. Hildebrand (1954) mentioned that this is a small species and the largest fish he

measured was 178 mm. Miller's (1965) largest fish was 155 mm. We took a number of individuals over 200 mm TL and the largest was 270 mm TL. Since size ranges were fairly standard over the entire year, length-frequency data proved to be of little value in determining growth rate. This species was obtained at temperatures and salinities varying from 14.5° to 29.0°C and from 23.2 to 38.7 ppt (Table 30).

Syacium papillosum (Linnaeus) - Dusky flounder

Twenty-eight *S. papillosum* were caught in 1968 (2) and 1969 (26). Specimens measured 114 to 270 mm TL and were taken at salinities and temperatures ranging between 16.6 to 37.4 ppt and 14.1° to 20.9°C. The majority of specimens were taken at 10 and 20 fathoms. Springer and Bullis (1956) caught *S. papillosum* in northern Gulf hauls. Hildebrand (1954) and Moe and Martin (1965) reported the species with Moe and Martin (1965) predicting an early summer spawning. Our fish were taken in January, February, March and November. The *S. papillosum* reported by Gunter (1933) were actually *S. gunteri*. It seems to be a more offshore fish than the latter species.

Trichopsetta ventralis (Goode and Bean) - Sash flounder

One hundred sixty-three specimens were taken at temperatures and salinities from 15.3° to 25.3°C and 19.9 to 37.8 ppt. A size range of 65 to 225 mm TL was recorded. These fish were taken from 20- to 50-fathom depths in all months except November, December, and January. About 85% of the catch came from 50 fathoms with catch per unit of effort in day hauls being greater than in night hauls.

SOLEIDAE - Soles

Gymnachirus melas Nichols - Naked sole

A single specimen of *G. melas* was taken in March 1968 from 40 fathoms. The fish measured 153 mm TL and weighed 44.0 g. The temperature was 18.0°C and the salinity was 34.0 ppt.

Gymnachirus texae (Gunter) - Naked sole

A total of 117 specimens ranging from 64 to 125 mm TL with a total weight of 1.776 kg were collected. Salinities ranged from 16.6 to 37.8 ppt and temperatures were between 14.1° and 29.0°C. This species of *Gymnachirus* has been uncommonly reported from the northern Gulf.

Supposedly the greatest depth recorded for this species is 58 fathoms (Springer and Bullis 1956).

TABLE 30
DISTRIBUTION OF *SYACIUM GUNTERI* BY BOTTOM SALINITY AND
TEMPERATURE INTERVALS SHOWING NUMBER OF SAMPLES, CATCH PER
UNIT OF EFFORT, MINIMUM, MAXIMUM AND MEAN TOTAL LENGTH (MM).
1967

TEMP INT. C	SALINITY INTERVAL PPT									
	16.6 16.9	17.0 19.9	20.0 22.9	23.0 25.9	26.0 28.9	29.0 31.9	32.0 34.9	35.0 37.9	38.0 39.8	16.6 39.8
SMPLS. 10.8 CATCH 12.9 MIN-MAX MEAN	0	0	0	0	0	0	0	0	0	0
SMPLS. 13.0 CATCH 15.9 MIN-MAX MEAN	0	0	0	0	0	1 0.000	6 0.000	1 0.000	0	8 0.000
SMPLS. 16.0 CATCH 18.9 MIN-MAX MEAN	0	0	0	0	1 0.000	1 16.000	4 1.250	13 1.307	0	19 2.000
SMPLS. 19.0 CATCH 21.9 MIN-MAX MEAN	U	U	U	U	U	2 0.000	4 11.000	21 0.904	0	27 2.333
SMPLS. 22.0 CATCH 24.9 MIN-MAX MEAN	0	0	0	0	0	1 0.000	1 0.000	12 2.166	0	14 1.857
SMPLS. 25.0 CATCH 27.9 MIN-MAX MEAN	0	0	0	0	0	4 0.000	2 2.000	18 1.166	0	24 1.041
SMPLS. 28.0 CATCH 29.5 MIN-MAX MEAN	0	0	0	0	0	0	2 3.000	0	0	2 3.000
SMPLS. 10.8 CATCH 29.5 MIN-MAX MEAN	0	0	0	0	1 0.000	9 1.777	19 3.105	65 1.276	0	94 1.680

1968

TEMP INT. C	SALINITY INTERVAL PPT									
	16.6 16.9	17.0 19.9	20.0 22.9	23.0 25.9	26.0 28.9	29.0 31.9	32.0 34.9	35.0 37.9	38.0 39.8	16.6 39.8
SMPLS. 10.8 CATCH 12.9 MIN-MAX MEAN	0	0	0	0	0	0	0	0	0	0
SMPLS. 13.0 CATCH 15.9 MIN-MAX MEAN	0	0	0	1 0.000	4 0.250	6 0.666	6 0.666	0	0	11 0.454
SMPLS. 16.0 CATCH 18.9 MIN-MAX MEAN	0	0	0	2 23.500	2 5.000	3 13.666	6 4.000	8 0.625	0	21 6.047
SMPLS. 19.0 CATCH 21.9 MIN-MAX MEAN	0	0	0	3 2.333	8 1.750	3 0.000	5 0.125	5 3.000	1 0.000	28 1.321
SMPLS. 22.0 CATCH 24.9 MIN-MAX MEAN	0	0	0	0	2 0.500	0	2 0.500	4 0.000	0	8 0.250
SMPLS. 25.0 CATCH 27.9 MIN-MAX MEAN	0	0	0	1 0.000	1 1.000	3 1.000	1 0.000	6 5.666	3 0.666	15 2.666
SMPLS. 28.0 CATCH 29.5 MIN-MAX MEAN	0	1 0.000	0	0	2 0.500	3 4.333	1 0.000	1 7.000	0	8 2.625
SMPLS. 10.8 CATCH 29.5 MIN-MAX MEAN	0	1 0.000	0	7 7.714	19 1.473	12 4.750	24 1.250	24 2.541	4 0.500	91 2.549

TABLE 30 (Continued)

TEMP INT. C	SALINITY INTERVAL PPT									
	16.6 16.9	17.0 19.9	20.0 22.9	23.0 25.9	26.0 28.9	29.0 31.9	32.0 34.9	35.0 37.9	36.0 39.8	36.6 39.8
10.8 CATCH 12.9 MIN-MAX MEAN	0	0	0	0	0	0	1 0.000	1 0.000	0	2 0.000
13.0 CATCH 15.9 MIN-MAX MEAN	1 0.000	0	0	2 0.000	1 0.000	7 0.428 139- 159 149.3	6 0.000	1 1.000 148- 148 148.0	0	18 0.222 139- 159 149.0
16.0 CATCH 18.9 MIN-MAX MEAN	0	0	1 0.000	0	0	1 4.000 143- 144 143.7	7 0.457 99- 157 131.1	13 0.692 151- 201 154.2	2 0.000	24 0.791 99- 201 147.1
19.0 CATCH 21.9 MIN-MAX MEAN	0	1 0.000	0	3 0.000	0	0	5 0.000	6 0.000	0	15 0.000
22.0 CATCH 24.9 MIN-MAX MEAN	0	0	0	1 0.000	0	0	0	0	0	1 0.000
25.0 CATCH 27.9 MIN-MAX MEAN	0	0	0	0	0	0	0	0	0	0
28.0 CATCH 29.5 MIN-MAX MEAN	0	0	0	0	0	0	0	0	0	0
10.8 CATCH 29.5 MIN-MAX MEAN	1 0.000	1 0.000	1 0.000	6 0.000	1 0.000	8 0.875 139- 159 146.1	19 0.315 99- 157 131.1	21 0.476 151- 201 158.1	2 0.000	60 0.383 99- 201 147.4

CYNOGLOSSIDAE - Tonguefishes

Symphurus diomedianus (Goode and Bean) - Tonguefish

Two specimens of *S. diomedianus* were taken. A March 1967 fish from 50 fathoms measured 150 mm TL and weighed 25.1 g. The second specimen was collected from 20 fathoms in January 1967. This fish measured 153 mm TL and weighed 44.0 g. The March temperature and salinity were 20.0°C and 37.8 ppt, respectively. The temperature and salinity for the January collection were 18.4°C and 36.7 ppt.

Symphurus plagiusa (Linnaeus) - Tonguefish

Symphurus plagiusa appeared in 1967 (33); 1968 (14) and 1969 (17). They were found at all stations. Specimens ranged in size from 102 to 156 mm TL and were taken at temperatures and salinities from 14.0° to 26.1°C and 26.2 to 37.2 ppt. These fish were taken in all months with the exception of June and November. Gunter (1945) found that 90.6% of his specimens were taken at salinities above 30.0 ppt. Miller (1965) found no apparent seasonal trends in either lengths or numbers caught. Our data show a preference for salinities above 29.0 ppt.

Ginsburg (1951) recorded a maximum depth of 14 fathoms for

this species and indicated that greater numbers were taken in inshore waters. Hildebrand (1954) increased the known depth range to 23 fathoms. Although most of our specimens came from 10 fathoms or less, we collected seven specimens at 30 fathoms, one at 40 fathoms and one at 50 fathoms.

In inshore GMEI samples, *S. plagiusa* was eighteenth in numerical abundance. Total lengths ranged from 25 to 180 mm in all salinity intervals above 2.0 ppt. The highest CPUE (sizes 45 to 180 mm TL) was made at salinities above 30.0 ppt, and was followed closely by the CPUE (sizes, 38 to 121 mm TL) at 15.0 to 19.9 ppt. Maximum size inshore increased with salinity.

ECHENEIFORMES

ECHENEIDAE - Remoras

Echeneis naucrates Linnaeus - Sharksucker

The sharksucker, *E. naucrates*, was taken on three occasions. In March 1967 a 383 mm TL specimen weighing 230.5 grams was collected at a temperature and salinity of 20.0°C, and 36.7 ppt from Station 4. Two years later in 1969, again in March and at the same station, another specimen of the same size (383 mm) was taken at a temperature and salinity of 16.9°C and 35.7 ppt. In June 1967 a specimen measuring 602 mm was encountered at 30 fathoms at a temperature and salinity of 25.1°C and 36.8 ppt. This species was on numerous occasions seen associated with sharks and the cobia, *Rachycentron canadum*.

TETRAODONTIFORMES

BALISTIDAE - Triggerfishes and filefishes

Alutera scripta (Osbeck) - Scrawled filefish

Alutera scripta (56 to 339 mm TL) was collected in 1967 (29 specimens) and 1968 (19 specimens). Temperatures and salinities were 15.2 to 26.5°C and 26.5 to 37.4 ppt. This species has been uncommonly reported from offshore waters in the northern Gulf.

Balistes capriscus Gmelin - Gray triggerfish

This species of triggerfish occurred in all years, and 26 specimens ranged in size from 107 to 335 mm TL. Temperatures and salinities were 14.0° to 24.0°C and 16.6 to 37.4 ppt. Specimens were taken no deeper than 30 fathoms. Gunter (1945) and Miller (1965) took only one specimen each.

Monacanthus hispidus (Linnaeus) - Planehead filefish

Two specimens taken in 1967 appeared at Stations 1 and 4 in a temperature and salinity range of 14.3° to 16.4°C and 32.1 to 35.6 ppt. The 1968 catch (2) was collected in one sample in December at Station 4. A temperature and salinity of 21.8°C and 31.8 ppt were noted at this time. Four specimens were taken from Station 4 in 1969. Ranges in temperature and salinity were 15.5° to 19.8°C and 34.0 to 37.4 ppt. Specimens ranged from 46 to 134 mm TL with a total mass of 249.3 g.

GMEI samples included 44 *M. hispidus* (15 to 58 mm TL) from salinities above 20 ppt.

OSTRACIIDAE - Trunkfishes

Lactophrys quadricornis (Linnaeus) - Cowfish

Twenty-one cowfish were taken during the three years. Temperatures and salinities from 13.5° to 17.0°C and 26.2 to 33.2 ppt were noted for these specimens. Sizes ranged from 163 to 230 mm TL. This species is commonly taken from inshore grass beds during the warm months. Early juveniles were included in GMEI samples.

The cowfish population is not large enough to support a commercial fishery but a large cowfish contains two small portions of white meat with excellent flavor and texture. Fishermen often select this species for their use (fide J.Y. Christmas).

TETRAODONTIDAE - Puffers

Lagocephalus laevigatus (Linnaeus) - Smooth puffer

Twenty-two specimens were taken during the three years. Smooth puffers ranged from 65 to 227 mm TL and were collected in waters ranging from 15.2° to 27.0°C and 24.9 to 37.9 ppt. Hildebrand (1954) noted the preference of this species for deep water. Gunter (1945) did not collect *L. laevigatus*. Miller (1965) suggested an offshore spawning period during the fall in south Texas. We have taken a few specimens in miscellaneous trawl hauls in Mississippi Sound.

Sphaeroides nephelus (Goode and Bean) - Southern puffer

A total of forty-eight specimens appeared at temperatures and salinities ranging from 13.3° to 25.2°C and 26.6 to 37.4 ppt. Fish ranged in size from 51 to 105 mm TL. Hildebrand (1954) reported a number of specimens from deep waters (15 fathoms; 27 meters, and deeper). Gunter (1945) and Miller (1965) stated that a fall and winter

offshore movement seemed apparent. The present data agree with this observation. In colder months the catches of *S. nephelus* in our samples increased.

This species was twentieth in order of numerical abundance taken by GMEI trawls and seines. In the estuarine study area they ranged from 12 to 105 mm TL and were taken at all salinities encountered above 5.0 ppt. Catch per haul decreased in the colder months.

DIODONTIDAE - Porcupinefishes

Chilomycterus schoepfi (Walbaum) - Striped burrfish

Eight specimens were collected; two in 1967, four in 1968 and two in 1969. The 1967 fish were taken from Station 1 at temperatures and salinities ranging from 14.2° to 14.3°C and from 32.1 to 32.5 ppt. In 1968 they were found at temperatures from 15.1° to 26.4°C and at salinities from 26.2 to 26.6 ppt. A temperature range from 10.8° to 20.2°C and a salinity of 33.2 ppt were noted for the 1968 specimens. Total length ranges were from 120 to 162 mm TL with a total mass of 892.6 g.

Springer and Bullis (1956) listed *C. schoepfi* throughout the Gulf to depths of 50 fathoms. Our data show specimens from depths no greater than 10 fathoms. Gunter (1945) took 26 specimens, all in lower bay waters.

In GMEI samples *C. schoepfi* (22 to 186 mm TL) were taken in salinities above 15 ppt. We have found them most often associated with grass beds around the barrier islands.

BATRACHOIDIFORMES

BATRACHOIDIDAE - Toadfishes

Porichthys porosissimus (Cuvier) - Atlantic midshipman

The midshipman produced 104 specimens during this study at temperatures and salinities ranging from 14.1° to 28.0°C and 16.6 to 38.6 ppt. A total size range of 75 to 189 mm TL was recorded. Springer (1957) noted their disappearance from the bays from October through April, and our data show a greater offshore catch during January and October. It has been generally assumed spawning takes place in the spring and summer.

The midshipman was in the GMEI study area. All specimens ranged from 30 to 196 mm TL in water temperatures above 15.0°C (with one exception, a small number of fish from 10.0° to 14.9°C) and salinities above 5.0 ppt.

LOPHIIFORMES

LOPHIIDAE - Goosefishes

Lophiomus sp.

An unidentified species of *Lophiomus* was taken during this study. The specimen measured 108 mm and was taken at a temperature and salinity of 15.3°C and 34.6 ppt respectively. Capture occurred at 50 fathoms in March 1968. This fish was deposited in the Gulf Coast Research Laboratory museum.

ANTENNARIIDAE - Frogfishes

Antennarius radiosus Garman - Singlespot frogfish

Forty-nine specimens were found in waters deeper than 10 fathoms at temperatures and salinities between 16.6° and 25.0°C and 19.9 and 37.4 ppt. Hildebrand (1954) found this species to be common in deep waters. Our specimens ranged from 42 to 170 mm TL in size. We have periodically collected *A. radiosus* in Mississippi Sound.

OGCOEPHALIDAE - Batfishes

Dibranchius atlanticus Peters

A total of 235 specimens (39 to 93 mm TL) appeared in 1967 and 1968 at temperatures of 14.8° to 28.9°C and salinities of 23.2 to 37.8 ppt.

This species was collected at all stations except the 5-fathom station. Catch per unit of effort was greatest at 30 fathoms.

Halieutichthys aculeatus (Mitchill) - Spring batfish

Specimens were taken in 1968 (77) and 1969 (40) with a size range of 61 to 98 mm TL being recorded. A temperature range of 15.2° to 29.0°C, and a salinity range of 19.9 to 38.2 ppt were noted. This species has been rarely reported. Hildebrand (1954) took 163 specimens, and Miller (1965) found only one at 9 fathoms, while noting a possible preference for deeper offshore waters. During this study the majority of fish were from the 40- and 50-fathom stations. They occurred in increasing numbers from 20 to 50 fathoms and were found at Stations 2 and 3 in August and November only. No specimens were taken in July.

Ogcocephalus parvus Longley and Hildebrand - Roughback batfish

One individual, 68 mm TL and 8.0 grams, was taken in 40 fathoms during March 1967. The salinity and temperature were 36.2 ppt and 19.0°C respectively.

Ogcocephalus sp.

Forty-three unidentified specimens of *Ogcocephalus* were collected during the study. These individuals ranged from 56 to 294 mm TL. Temperatures and salinities ranged from 14.8° to 29.0°C and 23.2 to 37.4 ppt respectively. These specimens have been deposited in the Gulf Coast Research Laboratory museum.

Relative Abundance

Twenty-three species of fishes contributed 96.08% of the total number of fishes (Table 31). Twelve species of invertebrates included 95.21% of the total number of invertebrates (Table 32). These 35 species comprised 95.84% of the total catch.

The contribution of the numerically more abundant fishes to the total mass of the catch is shown in Figure 9. The order of abundance by weight changes from a similar arrangement by numbers although the species are the same. Croaker, longspine porgy, spot, seatrout, lizard fish, butterfish, pinfish, bank sea bass, sea catfish and blackfin searobin, in that order, include most of the 93.88% (Table 31) of total mass of fishes contributed by the 23 numerically most abundant species.

Roithmayr (1965) found that croaker, spot, seatrout, cutlass fish, sea catfish and longspine porgy comprised about 85% of the offshore industrial bottomfish catch from 1959 through 1963. The cutlass fish comprised 1% of the commercial catch but was not an abundant fish in our samples. The other five species listed by Roithmayr (1965) comprised 82.44% of our samples, but not in the same order.

The longspine porgy was the second most abundant fish by weight in our samples. This position was occupied by the spot in the industrial catch study. This difference is accounted for by the abundance of porgies at depths greater than 20 fathoms. Most of the commercial fishing was done in depths less than 20 fathoms; however, our samples extended out to the 50-fathom curve.

Croakers comprised 43.5% of our samples but accounted for 51% of the offshore industrial catch. This difference can be accounted for by the commercial fisherman's search for croaker concentrations.

TABLE 31
RELATIVE NUMBERS OF THE MOST ABUNDANT FISHES TAKEN IN TRAWL HAULS.

	Number Taken	Percentage of Total Catch	Percentage of the Total Catch of Fishes	
			Number	Weight
<i>Anchoa hepsetus</i>	2,052	1.73	2.19	0.43
<i>Anchoa mitchilli</i>	1,684	1.42	1.79	0.04
<i>Centropristes ocyurus</i>	951	0.80	1.01	1.17
<i>Chloroscombrus chrysurus</i>	229	0.19	0.24	0.08
<i>Cyclopsetta chittendeni</i>	357	0.31	0.40	0.38
<i>Cynoscion arenarius</i>	2,657	2.24	2.83	5.54
<i>Vibranchus atlanticus</i>	235	0.19	0.25	0.03
<i>Diplectrum arcuatum</i>	371	0.31	0.39	0.14
<i>Etropus crossotus</i>	345	0.29	0.36	0.06
<i>Galeichthys felis</i>	552	0.46	0.58	0.95
<i>Harengula pensacolae</i>	266	0.22	0.28	0.07
<i>Lagodon rhomboides</i>	1,990	1.68	2.12	2.27
<i>Leiostomus xanthurus</i>	6,457	5.46	6.90	11.50
<i>Leopohidium grasellsi</i>	277	0.23	0.29	0.20
<i>Micropogon undulatus</i>	32,669	27.63	34.91	43.50
<i>Peprilus burti</i>	7,016	5.93	7.49	2.44
<i>Prionotus rubio</i>	877	0.74	0.93	0.86
<i>Serranus atrobranchus</i>	305	0.25	0.32	0.08
<i>Stenotomus caprinus</i>	26,612	22.50	28.44	20.95
<i>Syacium gunteri</i>	413	0.34	0.44	0.17
<i>Synodus foetens</i>	1,413	1.19	1.51	2.71
<i>Trachurus lathami</i>	1,960	1.65	2.09	0.25
<i>Vomer setapinnis</i>	300	0.25	0.32	0.06
TOTAL.....	90,006	76.01	96.08	93.88

TABLE 32
RELATIVE NUMBER OF THE 12 MOST ABUNDANT INVERTEBRATE SPECIES CAUGHT.

Species	Number Caught	% of Total catch	% of Total invertebrates
<i>Renilla mulleri</i>	16,808	14.21	68.14
<i>Penaeus aztecus</i>	2,694	2.27	10.92
<i>Lolliguncula brevis</i>	962	0.80	3.75
<i>Squilla empusa</i>	628	0.54	2.54
<i>Penaeus fluviatilis</i>	450	0.39	1.82
<i>Sicyonia dorsalis</i>	345	0.30	1.39
<i>Luidia clathrata</i>	330	0.28	1.33
<i>Callinectes similis</i>	304	0.26	1.23
<i>Loligo pealei</i>	294	0.17	1.19
<i>Trachypeneus similis</i>	272	0.23	1.10
<i>Aurellia aurita</i>	250	0.21	1.01
<i>Penaeus duorarum</i>	195	0.17	0.79
Totals	23,496	19.83	95.21

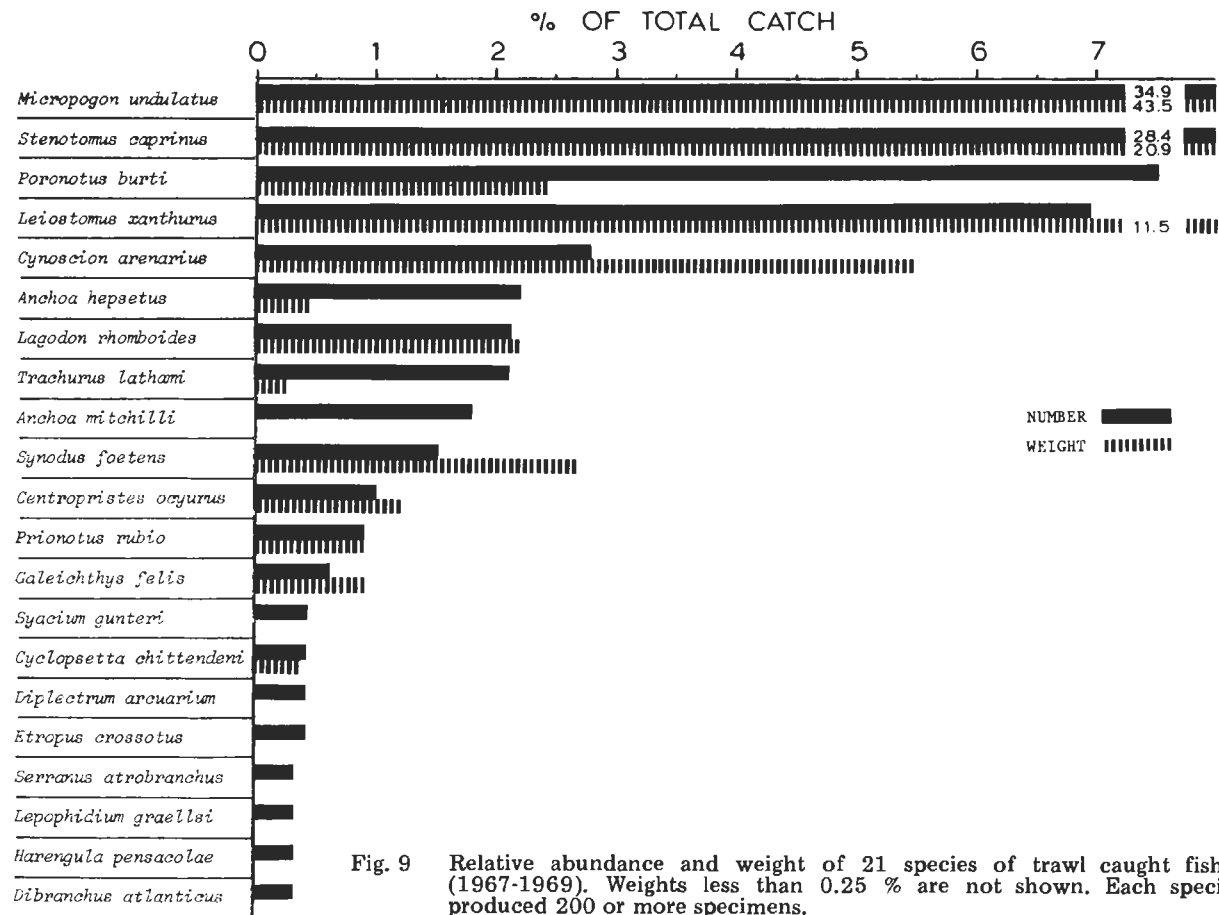

There is no evidence in our data that would indicate any great change in the species composition of the offshore fish population since Roithmayr's (1965) study.

Seasonal Bathymetric Distribution

The five numerically most abundant species in our samples comprised 85.15% of the weight of fishes caught by trawl. The most abundant commercially exploited invertebrate species was the brown shrimp (Table 32).

In our catch the ratio of shrimp-to-fish was far below the estimate (1:8, Roithmayr 1965) made for the shrimp fishery in 0-20 fathoms. Shrimp fishermen work only in concentrations of shrimp, and most of the catch is taken in less than 25 fathoms; consequently, we expected the shrimp catch to be relatively small.

In Figures 10 and 11 the seasonal bathymetric distribution of the five most abundant fishes and the brown shrimp have been illustrated. Relative species abundance is also evident when total areas of figures

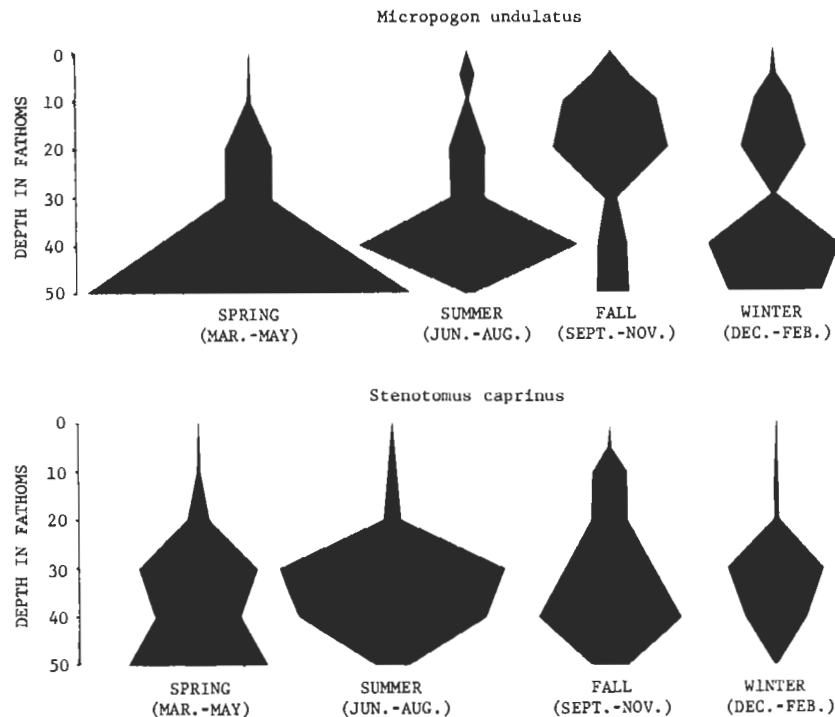

Fig. 10 Offshore seasonal bathymetric distribution of *Micropogon undulatus* and *Stenotomus caprinus*.

are compared. These figures and tables show seasonal movement in the study area. All of these species except the longspine porgy are abundant in the adjacent estuarine study area (GMEI data) as juveniles.

Length-Frequency Distribution

Monthly length-frequency distributions for the most abundant species were plotted. These figures represented the catch for each species from May 1967 through April 1969. Aliquots were used to estimate the total number per interval for each sample. The percentage of the monthly sample for each interval was based on the total catch for the month at all stations.

Two or three modal groups were evident in most distributions. Recruitment of growing young was evident. Growth rate could be followed to some extent but is often confused by the long period of recruitment and overlapping of age groups.

Estuarine Relationships

The importance of estuarine nursery areas to commercial fishery production has been well documented in the last forty years. Relatively little attention has been given to the relationship of estuaries as generally defined to the offshore environment where all but a very few of the species comprising our estuarine dependent resources spend a part of their lives and spawn. These include, with the exception of oysters and possibly a part of the blue crab population, nearly all of the species contributing significant production to Mississippi Landings. This project was designed for close coordination with the concurrent cooperative GMEI program.

In the accounts of species encountered in offshore samples we have (*loc. cit.*) included some of the comparable data from GMEI samples:

McHugh (1966) wrote as follows:

“The estuarine environment, to satisfy the fisheries scientists, must include the offshore zone affected by land drainage. Otherwise no fishery resources other than oysters and clams can be considered entirely estuarine. Nevertheless, almost two-thirds of the United States' Commercial catch and much of the marine sport catch is composed of species that spend at least a part of their lives within the land-bound estuaries.”

In the same paper McHugh suggested that:

"It is perhaps best to define two estuarine zones, 'inshore estuary' and the 'offshore estuary' which is that region of the open sea in which the surface waters are measurably diluted by land drainage. The offshore limit of this zone has been defined arbitrarily as the 33.5⁰/₀₀ isohaline."

Although detailed relationships of the inshore and offshore data must await further study, a few observations are in order now. The results of this study have shown that all of our stations should be included in the "offshore estuary" as defined by McHugh (1966). The highest annual mean surface salinity (Table 4) was 32.9 ppt at the 50-fathom stations. Fisheries production and management in these areas are inextricably linked.

About 64% of the 179 species collected in this project have been observed in the Mississippi Sound.

Among the species making significant contribution to commercial fisheries production in Mississippi, only the longspine porgy was not also abundant in GMEI samples. The seasonal bathymetric distribution (Figure 10) of porgies in our samples shows its preference for deeper water. This does not necessarily mean that the porgy, or any other species found in offshore waters for that matter, is independent of the "inshore estuary". Practically nothing is known of the food requirement nor the source of food production for the porgy or other species that live in offshore waters without physically occupying the inshore estuary. The well known role of the inshore estuary as a nursery area is unquestionably most important. Relatively little attention has been given to the relationship of forage species and nutrients in estuarine and offshore waters.

Acosta (1970) listed fourteen species of copepods collected at our offshore stations. All but four of these (71%) were found in concurrent copepod studies at GMEI stations (Fig. 2). Some of these species are generally accepted as being oceanic. Although the presence of oceanic species in the inshore estuary may be transitory they are, nevertheless, a part of the estuarine biota.

Data from our GMEI and offshore studies are compatible. Detailed study of the combined data should add considerably to knowledge of those species.

In general the mean length of specimens from the same fish species was less in GMEI samples than in offshore samples but maximum size in GMEI samples exceeded minimum size in offshore population. At least part of the adult population continues to utilize inshore waters some of the time in addition to depending on the inshore nursery area for their early development.

Few specimens of coastal pelagic species known to be abundant in the study area for at least a part of the year were collected in our samples. In this group menhaden is an outstanding example of an estuarine-dependent species that is already heavily exploited. Estimates of large unexploited pelagic resources and technological advances in fishing methods will undoubtedly lead to exploitation of other near shore pelagic resources. We still know little about this very large resource and its environmental relationships and requirements.

Summary

1. From January 1967 through May 1969 a seasonal study of the nektonic and benthic faunas of the shallow Gulf off Mississippi was conducted. Sampling was carried out aboard the *R/V Gulf Researcher*. The need for acquisition of information in these waters has been emphasized by the expanding offshore fisheries.

2. Fixed stations were located in a southeasterly transect across the continental shelf at depths of 5, 10, 20, 30, 40 and 50 fathoms. Stations were occupied a total of 245 times during the 29-month sampling period.

3. An effort was made to obtain monthly day and night trawl, nekton and plankton samples. Quarterly dredge samples were obtained from November 1967 through May 1969. Sampling procedures and physical data were recorded on field sheets on board the vessel and later transferred to GMEI formats for the purposes of electronic data processing.

4. Water samples were obtained from three depths (surface, midwater and bottom) each time a station was occupied. Surface temperatures were read with a mercury, Celsius thermometer. Midwater and bottom temperatures were taken by "fisheries-type" reversing thermometers which were attached to Nansen bottles. Water samples were frozen on board the vessel for the purpose of shore laboratory analyses. Samples were tested for the presence of nitrates, nitrites, ortho-phosphates and total phosphates. Secchi disc readings were made in order to determine approximate water transparency.

Average temperatures decreased from surface to bottom at all stations. Differences increased with depth from 10 to 50 fathoms. Average bottom temperature showed a maximum difference of 2.4°C between Stations 3 and 6. Only 0.1°C difference in the average bottom temperature occurred at Stations 1 and 6. Minimum temperature averages occurred in January at Stations 1 and 4 and in February at other stations. The maximum average temperature (32°C) was found in

June at Station 4. Seasonal temperature variations were less at the bottom than at the surface.

Monthly average salinities ranged from 13.1 to 38.8 ppt with the maximum observation occurring at Station 3 in June 1968 (midwater). Maximum salinities had a range of 11.8 ppt at the surface and decreased to 6.8 ppt at the bottom. There was no clear pattern of areal or vertical distribution of salinity. Apparently salinity in the study area was more stable in the colder months. Two seasonal peaks of nitrate concentrations were evident throughout the water column, with the highest concentration usually appearing in January. Nitrites were not detected.

Seasonal peaks in total phosphate concentration generally occurred when nitrates were low. Seasonal trends were similar at all stations throughout the water column. The total phosphate concentration was highest (3.25) at Station 1 at midwater in May 1969.

The minimum transparency observation (4 feet) was noted at Station 4 in June. Maximum observations increased from 28 to 130 feet as distances offshore increased.

5. Bottom samples were taken by a Forest grab at quarterly intervals. Stations 1, 2 and 3 show the finest sediments. Station 4 showed a high percentage of sand. Station 5 was variable in sand content (12 to 90%) throughout the study. Station 6 showed particles similar in size to those found at Stations 1, 2 and 3.

Shell debris and foraminiferal tests were present at all stations. The majority of stations showed silty mud or sandy silt.

Foraminiferal populations followed expectations with shallow water forms found at Stations 1, 2 and 3, and deeper-water and pelagic forms found at 4, 5 and 6.

6. Plankton samples were collected from three levels (surface, midwater and bottom). Nets were towed for a period of 20 minutes. Nets measured 50 cm across the mouth and 200 cm in length (from mouth to bucket). Number 3 mesh nylon netting was used. The majority of samples and accumulated data were destroyed in hurricane Camille with only 71 samples (March through December 1968) being salvaged for re-examination.

Samples were examined for abundant, commonly occurring forms, and their relative abundance was noted. Copepods were the most abundant zooplankters. Brachyuran zoea and megalops, Stomatopod larvae, *Lucifer faxoni*, *Acetes a. carolinae*, *Penilia avirostris*, *Doliolum*

sp., and fish eggs and larvae were abundant.

7. Dredging operations were begun in November 1967, and quarterly samples were taken. A total of 43 hauls were made. Twelve invertebrate and three vertebrate species were collected. *Renilla mülleri* was the most abundant species encountered, followed by *Squilla empusa* and *Callinectes similis*. Other invertebrate species were not nearly as abundant. *Centropristes ocyurus*, *Citharichthys spilopterus* and *Etropus crossotus* were the only fishes taken in dredge hauls. The microscopic infauna was apparently very sparse.

8. Surface and benthic nekton samples were obtained each time a station was occupied. A total of 245 surface and 152 benthic hauls were made. The nekton net was towed for 30 minutes.

All nekton data were lost in Hurricane Camille (August 1969). Up to this time the majority of collected specimens had been identified, and due to familiarity of records a list has been prepared of the species which were encountered most often.

9. Trawl sampling was done with a 40-foot balloon trawl. Each trawling operation lasted for a period of 30 minutes. Specimens were sorted, counted, preserved and labeled in the field. Laboratory work consisted of further identification of specimens and recording their measurements and weights.

Trawling produced a total of 118,242 specimens. The catch consisted of 50 species (24,679 specimens) of invertebrates and 129 species of fishes (93,563 specimens). Station 1 produced over 21% of the trawl catch and Stations 2 and 3 produced over 12 and 10% respectively. Over 13% of the trawl catch was taken at Station 4, and Station 5 produced the greatest percentage (22.7). The catch from Station 6 was 19.5% of the total.

Renilla mülleri was the most abundant invertebrate encountered, comprising 68.14% of the number of invertebrates. The commercially exploited brown shrimp, *Penaeus aztecus*, was second in abundance (10.92% of the invertebrate catch). Twelve species of invertebrates contributed 95.21% of the total invertebrate catch.

Twenty-three species of fishes comprised 96.2% of the total fish catch. The five most abundant species comprising 80.60% numerically, were croaker, longspine porgy, butterfish, spot and seatrout. In decreasing order of contribution by weight were the croaker, longspine porgy, spot, seatrout, lizardfish, butterfish, pinfish, bank sea bass, sea catfish and blackfin searobin. These species comprised 91.89% of the total weight of fishes.

The families Sciaenidae, Sparidae and Stromateidae were represented by the greatest numbers and comprised 83.2% of the total catch. Families considered to be of commercial importance contributed 93.2% to the total catch.

10. The seasonal bathymetric distributions of *Penaeus aztecus*, *Micropogon undulatus*, *Stenotomus caprinus*, *Peprilus burti*, *Leiostomus xanthurus* and *Cynoscion arenarius* were illustrated. Seasonal movements and relative abundance of these species were evident.

11. Monthly length-frequency distribution for the brown shrimp croaker, longspine porgy, butterfish, spot and seatrout showed two or three modal groups in the majority of distributions. Both overlapping age groups and recruitment make growth rate determinations uncertain.

12. Relative species abundance indicated that fish stocks in the study area continue to maintain themselves under the current rate of exploitation by the industrial bottomfish fishery.

13. Few specimens of coastal pelagic species known to be abundant in the study area were collected and the void in our understanding of these resources remains.

Literature Cited

- Abbott, R.T.A. 1954. "American Seashells" XIV 513 pp., 40 pls., D. Van Nostrand Co. Inc., New York.
- Acosta, Danny J. 1970. The copepods south of Dog Keys Pass; Their abundance, distribution, seasonal variation, temperature and salinity tolerances. Unpubl. Ph. D. Dissertation. Univ. South Miss. 1-VII, 1-78.
- Anderson, W. W. and M. J. Lindner. 1941. Notes on the flatfish *Engyophrys sentus* Ginsburg. *Copeia* 1941 (1): 23-27.
- Arnold, Edgar L., Jr. and John R. Thompson. 1958. Offshore spawning of the striped mullet, *Mugil cephalus* in the Gulf of Mexico. *Copeia*, (2): 130-132.
- Bailey, R.M., E.A. Lachner, C.C. Lindsay, C.R. Robins, P.M. Roedel, W.B. Scott, and L.P. Woods. 1960. A list of common and scientific names of fishes from the United States and Canada. Amer. Fish. Soc. Comm. on Names of Fishes, Spec. Publ. No. 2 (Sec. Ed., 1966): 1-102.
- Bearden, C.M. 1963. A contribution to the biology of the king whittings, Genus *Menticirrhus*, of South Carolina. Cont. Bears Bluff Lab., 38:1-27.
- Berry, Richard and J. Bruce Kimsey. 1964. Summary Information. Processed Rept. (Mimeo.). Bur. Comm. Fish. Biol. Lab., Galveston, Texas.
- Bigelow, H.B. and Mary Sears. 1939. Studies on the waters of the continental shelf, Cape Cod to Chesapeake Bay. III. A Volumetric Study of the Zooplankton. Mem. Mus. Comp. Zool. Harv., 54: 179-378.
- Broadhead, Gordon C. 1953. Investigations on the black mullet, *Mugil cephalus* L., in northwest Florida. Fla. St. Brd. Cons., Tech. Ser. No. 7: 1-33.
- Bullis, Harvey R., Jr. and John R. Thompson. 1967. Progress in exploratory fishing and gear research in Region 2. Fiscal year, 1966. U.S. Fish and Wildl. Ser., Cir. 265: i-iii + 1-14.

- Burkenroad, M.D. 1939. Further observations on Penaeidae of the northern Gulf of Mexico. Bull. Bingham Ocean. Coll., 6(6): 1-62.
- Caldwell, David K. 1955. Distribution of the longspined porgy, *Stenotomus caprinus*. Bull. Mar. Sci. Gulf and Carib., 5(3): 230-239.
- . 1957. The biology and systematics of the pinfish, *Lagodon rhomboides* (Linnaeus). Bull. Fla. St. Mus., 2(6): 77-173.
- . 1961. Populations of the butterfish, *Poronotus triacanthus* (Peck), with systematic comments. Bull. South Cal. Acad. Sci., 60(1): 19-31.
- Cameron, James N. 1969. Growth, respiratory metabolism and seasonal distribution of juvenile pinfish (*Lagodon rhomboides* Linnaeus) in Redfish Bay, Texas. Cont. Mar. Sci. Univ. Tex., Vol. 14: 19-36.
- Carpenter, James S. 1965. A review of the Gulf of Mexico Red Snapper Fishery. U.S. Fish and Wildl. Ser., Cir. 208: i-iii + 1-35.
- Christmas, J.Y., Gordon Gunter and Edward C. Whatley. 1960. Fishes taken in the menhaden fishery of Alabama, Mississippi and eastern Louisiana. U.S. Fish and Wildl. Ser., Spec. Sci. Rept. 339: 1-10.
- , Gordon Gunter and Patricia Musgrave. 1966. Studies of annual abundance of postlarval penaeid shrimp in the estuarine waters of Mississippi, as related to subsequent commercial catches. Gulf Research Rept., 2(2): 177-212.
- and Gordon Gunter. 1967. A summary of knowledge of shrimps of genus *Penaeus* and the shrimp fishery in Mississippi waters. Proc. of Symp. on Crust., Part IV. Marine Biol. Assoc. India.
- Clark, Eugenie and Katherine Von Schmidt. 1965. Sharks of the Central Gulf Coast of Florida. Bull. Mar. Sci., 15(1): 13-83.
- Collier, Albert. 1958. Gulf of Mexico physical and chemical data from ALASKA Cruises. Fish. Wildl. Ser. Spec. Sci. Rept. Fish., No. 249: 1-417.
- Combs, Ralph M. 1969. Embryogenesis, histology and organology of the ovary of *Brevoortia patronus*. Gulf Res. Rept., 2(4): 333-434.
- Darnell, Rezneat N. 1958. Food habits of fishes and larger invertebrates of Lake Pontchartrain, Louisiana, and estuarine community. Publ. Inst. Mar. Sci. Univ. Tex., Vol. 5: 353-416.
- Daugherty, F.M. 1952. The blue crab investigation, 1949-50. Tex. Jour. Sci., 4(1): 77-84.
- Dawson, C.E. 1958. A study of the biology and life history of the spot *Leiostomus xanthurus* Lacepede, with special reference to South Carolina. Bears Bluff Lab., No. 28.
- . 1966. Additions to the known marine fauna of Grande Isle, Louisiana. Proc. La. Acad. Sci. (1966): 175-180.
- . 1967. Contributions to the biology of the cutlass fish (*Trichiurus lepturus*) in the northern Gulf of Mexico. Trans. Amer. Fish. Soc., 96(2): 117-121.
- . 1968. Contributions to the biology of the Mexican Flounder, *Cyclosetts chittendeni*, in the northern Gulf of Mexico. Trans. Amer. Fish. Soc., 97(4): 504-507.
- Drennan, Kirby L. 1963. Surface circulations in the northeastern Gulf of Mexico. Gulf Coast Research Laboratory Ocean. Sect., Tech. Rept., No. 1: 1-116, 6 Figs., 26 pls., 19 Tabs.
- . 1966. Airborne measurements of infrared sea temperatures in the northern Gulf of Mexico. Gulf Coast Research Lab. Ocean. Sect. Tech. Rept., No. 2: 1-10, 21 Figs., 1 Tab.
- Eldred, Bonnie. 1959. A report on the shrimp (Penaeidae) collected from the Tortugas controlled area. Fla. St. Brd. Cons., Spec. Sci. Rept., No. 2: 1-6.
- Fuss, Charles M., Jr., John A. Kelly, Jr., and Kenneth W. Prest, Jr. 1969. Gulf thread herring: Aspects of the developing fishery and biological research. Inst. Mar. Sci. Gulf Carib., Fish Inst. Proc. 21st Ann. Sess. (1968): 111-125.

- Galtsoff, Paul S. 1954. Historical sketch of the explorations in the Gulf of Mexico. *In* Gulf of Mexico, Its origin, Waters and Marine Life. Fish. Bull. Fish. Wildl. Ser., 55(89): 39-65.
- Ginsburg, Isaac. 1951. Western Atlantic tonguefishes with descriptions of six new species. *Zoologica*, 36(3): 84-101.
- _____. 1952. Flounders of the genus *Paralichthys* and related genera in American waters. U.S. Fish Wildl. Ser. Fish. Bull., 71: 266-351.
- Gudger, E.W. 1918. Oral gestation in the gafftopsail catfish *Felichthys felis*. Carnegie Inst. Wash. Publ., No. 252: 25-32.
- Guest, William C. and Gordon Gunter, 1958. The sea trout or weakfishes (Genus *Cynoscion*) of the Gulf of Mexico. Gulf States Mar. Fish. Comm., Tech. Summ. 1: 1-40.
- Gunter, Gordon. 1933. The flatfish, *Syacium papillosum* (Linnaeus) in Louisiana Copeia. 1933 (1): 35.
- _____. 1936. Studies on the destruction of marine fish by shrimp trawlers in Louisiana. La. Cons. Res. 5(4): 18-24 and 45-46.
- _____. 1938a. The relative numbers of species of marine fish on the Louisiana coast. *Amer. Nat.*, Vol. 72: 77-83.
- _____. 1938b. Notes on invasion of freshwater by fishes of the Gulf of Mexico, with special references to the Mississippi-Atchafalaya River system. *Copeia*, (2): 69-72.
- _____. 1938c. Seasonal variations in abundance of certain estuarine and marine fishes in Louisiana, with particular reference to life histories. *Ecol. Monog.*, 8: 313-346.
- _____. 1941. Relative numbers of shallow water fishes of the northern Gulf of Mexico, with some records of rare fishes from the Texas Coast. *Amer. Midl. Nat.*, 20: 194-200.
- _____. 1945. Studies on Marine fishes of Texas. *Publ. Inst. Mar. Sci. Univ. Tex.*, 1(1): 1-190.
- _____. 1948. Notes on fishes of the genus *Scorpaena* from the South Atlantic and Gulf Coasts of the United States, with descriptions of two new species. *Copeia*. 1948. (3): 157-166.
- _____. 1950. Seasonal population changes and distribution, as related to salinity, of certain invertebrates of the Texas coast including the commercial shrimp. *Publ. Inst. Mar. Sci. Univ. Tex.*, 1(2): 7-51, 8 figs.
- _____. 1956a. Some relations of faunal distributions to salinity in estuarine waters. *Ecology*, 37(3): 616-619.
- _____. 1956b. A revised list of euryhaline fishes of North and Middle America. *The Am. Mid. Nat.*, 56(2): 345-354.
- _____. 1958. Menhaden populations. *In* Annual Report, Gulf Fishes Investigations. Mimeo. Rept.: 1-106.
- _____. and Gordon E. Hall. 1963. Additions to the list of euryhaline fishes of North America. *Copeia*, 3: 596-597.
- _____. and G.E. Hall. 1965. A biological investigation of the Calooshattee Estuary of Florida. *Gulf Research Reports* 2(1): 1-71.
- _____. and F.T. Knapp. 1951. Fishes, new, rare, or seldom recorded from the Texas coast. *Tex. Jour. Sci.*, 3(1): 134-138.
- Hardy, A.C. 1956. *The open sea. Its Natural History: The World of Plankton.* Houghton Mifflin Co., Boston: 335 pps.
- Herke, William M. 1971. Use of natural, and semi-impounded, Louisiana tidal marshes as nurseries for fishes and crustaceans. Ph.D. Dissertation, Louisiana State University, Baton Rouge, La. 242 pp.
- Hildebrand, Henry H. 1954. A study of fauna of the brown shrimp (*Penaeus aztecus* Ives) grounds in the western Gulf of Mexico. *Publ. Inst. Mar. Sci. Univ. Tex.*, 3(2): 233-366.

- _____. 1955. A study of the fauna of the pink shrimp, *Penaeus duorarum* (Burkenroad), grounds in the Gulf of Campeche. Publ. Inst. Mar. Sci. Univ. Tex. 4(1): 169-232.
- Hildebrand, Samuel F. 1963. Family Clupeidae. In Bigelow, Henry B., et al., Fishes of the Western North Atlantic, Memoir, Sears Found. Mar. Res., 1 (Part 3): 61-88.
- _____ and Louella E. Cable. 1930. Development and life history of fourteen teleostean fishes at Beaufort, North Carolina. Bull. U.S. Bur. Fish., 46(1931): 383-499.
- _____ and _____. 1934. Reproduction and development of whittings or kingfishes, drums, spot, croaker, and weakfish or sea trouts, family Sciaenidae, of the Atlantic Coast of the United States. Bull. Bur. Fish., 48: 41-117.
- _____ and _____. 1938. Further notes on the development and life history of some teleosts at Beaufort, N.C. Bull. Bur. Fish., 48: 506-642.
- Hoese, Hinton D. 1958. A partially annotated check-list of the marine fishes of Texas. Pub. Inst. Mar. Sci. Univ. Tex. 5: 312-353.
- _____ and R.B. Moore. 1958. Notes on the Life History of the Bonnetnose shark, *Sphyrna tiburo*. Texas Jour. Sci., 10(1): 69-72.
- Hopkins, T.L. 1966. The plankton of the St. Andrew Bay system of Florida. Publs. Inst. Mar. Sci. Univ. Tex., 11:12-64.
- Joseph, E.B. and R.W. Yerger. 1956. The fishes of Alligator Harbor, Florida, with notes on their life history. Fla. St. Univ. Stud., No. 22: 111-156.
- Kelly, John A., Jr. and Alexander Dragovich. 1968. Occurrence of macrozooplankton in Tampa Bay, Florida, and the adjacent Gulf of Mexico. Fish. Bull. Fish Wildl. Ser., 66: 209-221.
- Kramer, A. 1895. On the most frequent pelagic copepods and cladocers of the Hauraki Gulf. Trans. Proc. N.Z. Inst., 27: 214-223.
- Leipper, Dale F. 1954. Physical oceanography of the Gulf of Mexico. In Gulf of Mexico, Its Origin, Waters and Marine Life. Fish. Bull. Fish. Wildl. Ser., 55(89): 119-137.
- Lockhead, John H. 1954. On the distribution of a marine cladoceran, *Penilia avirostris* Dana (Crustacea, Branchipoda), with a note on its reported bioluminescence. Boil. Bull., 107(1): 92-105.
- Longley, William H. and Samuel F. Hildebrand. 1941. Systematic catalogue of the fishes of Tortugas, Florida, with observations on color, habits, and local distributions. Carnegie Institution of Washington, Pub. 535 (Papers of the Tortugas Laboratory, Vol. 34) 331 p., 34 pls. [Edited and completed by Samuel F. Hildebrand.]
- Lyles, Charles H. 1967. Fishery statistics of the United States 1965. U.S. Fish and Wildl. Ser., Bur. Comm. Fish.
- Marukawa, H. 1921. Plankton list and some new species of copepods from the northern waters of Japan. Bull. Inst. Oceanogr. Monaco., 18(383): 1-15.
- McHugh, J.L. 1966. Management of Estuarine Fishes. In A Symposium on estuarine fishes. Am. Fish. Soc., Sp. Publ., No. 3: 133-154.
- Meek, S.E. and S.F. Hildebrand, 1928. The marine fishes of Panama. Field Mus. Nat. Hist., Zoo. Ser. 14(3): xxv-xxix + 709-1,045.
- Miles, D.W. and E.C. Simmons. 1950. The menhaden fishery. Bull. Texas Game Fish and Oyster Comm., 30:1-28.
- Miller, John M. 1965. A trawl survey of the shallow gulf fishes near Port Aransas, Texas. Publ. Inst. Mar. Sci. Univ. Tex., 10:80-107.
- Moe, Martin A. and George T. Martin. 1965. Fishes taken in monthly trawl samples offshore of Pinellas County, Florida with new additions to the fish fauna of the Tampa Bay Area. Tul. Stud. in Zoo., 12(14): 129-151.
- Moore, Donald R. 1961. The marine and brackish water mollusca of the state of Mississippi. Gulf Res. Rept., 1(1): 1-58.

- Nelson, Walter R. 1969. Studies on the croaker, *Micropogon undulatus* Linnaeus and the spot, *Leiostomus xanthurus* Lacepede, in Mobile Bay, Alabama. *Journal of Marine Science* 1(1): 1-92.
- Osburn, Kenneth W., Bruce W. Maghan and Shelby B. Drummond. 1969. Gulf of Mexico shrimp atlas. *Bur. Comm. Fish., U.S. Dept. Int. Cir.* 312: 1-20.
- Pearson, J.C. 1929. Natural history and conservation of the redfish and other commercial sciaenids on the Texas Coast. *Bull. U.S. Bur. Fish.*, 44(1928): 129-214.
- Phillips, P.J., W.D. Burke and E.J. Keener. 1969. Observations on the trophic significance of jellyfish in Mississippi Sound with quantitative data on the associative behavior of small fish with medusae. *Trans. Amer. Fish. Soc.*, 98(4): 702-712.
- Reid, George K. 1954. An ecological study of Gulf of Mexico fishes in the vicinity of Cedar Key, Florida. *Bull. Mar. Sci. Gulf & Carib.*, 4(1): 1-94.
- Rivas, Luis R. 1968. Fisherman's atlas of monthly sea surface temperatures for the Gulf of Mexico. *Ich. Lab. Mus. Univ. Miami, Cont.* 58, *Cir.* 300: 1-33.
- Rothmayr, Charles M. 1965. Industrial bottomfish fishery of the northern Gulf of Mexico, 1959-63. *Fish and Wildl. Ser. Spec. Sci. Rept. Fisheries*, No. 518: 23 pp.
- Siebanaler, J.B. 1952. Fishes taken by the *M/V Oregon* in shrimp trawls off the coast of Mississippi, 1950-1952. *Mimeo. Report*: 1-7.
- Simmons, Ernest G. 1951. Fish Trap Investigation. Texas Game and Fish Comm. Marine Laboratory annual Report, 1950-51, 1-15 (Mimeographed).
- _____. 1957. An ecological survey of the Upper Laguna Madre of Texas. *Publ. Inst. Mar. Sci. Univ. Tex.*, 4(2): 156-200.
- _____ and H.D. Hoese. 1959. Studies on the hydrography and fish migration of Cedar Bayou, a natural tidal inlet on the central Texas coast. *Publ. Inst. Mar. Sci. Univ. Tex.*, 6:56-80.
- Springer, Stuart and H.R. Bullis. 1952. Exploratory shrimp fishing in the Gulf of Mexico. *Fishery leaflet. U.S. Fish and Wildl. Ser.*, 406: 1-34.
- _____ and _____. 1956. Collections by the *Oregon* in the Gulf of Mexico. *U.S. Fish and Wildl. Ser. Spec. Sci. Rept.*, 196: 1-134.
- _____ and J.R. Thompson. 1965. Collections by the exploratory fishing vessels *Oregon I*, *Silver Bay*, *Combat* and *Pelican* made during 1956-1960 in the southwest North Atlantic. *U.S. Fish, and Wildl. Ser. Spec. Sci. Rept.*, 50: 1-130.
- Springer, Victor G. 1957. Mysterious midshipman. *Tex. Game and Fish.*, 15(11): 6-7.
- _____ and Kenneth D. Woodburn. 1960. An ecological study of the fishes of the Tampa Bay area. *Fla. St. Brd. Cons. Prof. Papers.* 1: 1-104.
- Subrahmanyam, C.B. 1971. The relative abundance and distribution of penaeid shrimp larvae off the Mississippi Coast. *Gulf Research Reports*, 3(2): 291-345.
- Williams, Austin B. 1965. Marine decapod crustaceans of the Carolinas. *U.S. Fish and Wildl. Ser. Fish. Bull.*, 65(1): 1-298.
- Woodmansee, Robert A. 1966. Daily vertical migration of *Lucifer*. Planktonic numbers in relation to solar and tidal cycles. *Ecol.*, 47(5): 847-850.

Index

FAMILY AND GENERIC NAMES

Underlined page numbers indicate location of species accounts

Species	Page Number
<i>Acetes a. caroliniae</i>	28,29,30,31,32,43
Actinidae	45
<i>Alutera scripta</i>	43, <u>125</u>
<i>Anasimus latus</i>	<u>64</u>
<i>Anchoa hepsetus</i>	30, <u>35</u> , 43, <u>73</u> , 75, <u>130</u>
<i>Anchoa mitchilli</i>	<u>74</u> , 130
<i>Anchoa</i> sp.	29, <u>35</u>
<i>Ancylosetta dilecta</i>	<u>116</u>
<i>Ancylosetta quadrocellata</i>	<u>117</u>
<i>Anguilla rostrata</i>	<u>78</u>
Anguillidae	67, <u>78</u>
Antennariidae	67, <u>128</u>
<i>Antennarius radiosus</i>	<u>128</u>
Antherinidae	43
<i>Anthiasicus leptus</i>	<u>83</u>
<i>Aprionodon isodon</i>	69
<i>Archosargus probatocephalus</i>	<u>100</u>
Ariidae	67, <u>77</u>
<i>Astropecten duplicatus</i>	<u>65</u>
<i>Astropecten</i> sp.	<u>65</u>
Astropectinidae	<u>65</u>
<i>Astroscopus y-graecum</i>	<u>111</u>
Atherinidae	43
<i>Aurelia aurita</i>	<u>44</u> , <u>130</u>
<i>Bagre marinus</i>	<u>77</u>
<i>Bairdiella chrysur</i>	<u>90</u>
<i>Balistes capricus</i>	<u>125</u>
Balistidae	<u>37</u> , <u>39</u> , 43, 67, <u>125</u>
Batrachoididae	67, <u>127</u>
<i>Bellator militaris</i>	<u>109</u>
<i>Benthopagurus cokeri</i>	<u>57</u>
<i>Bollmannia communis</i>	<u>108</u>
Bothidae	28, 30, 37, <u>39</u> , 67, <u>116</u>
Branchiostegidae	67, <u>87</u>
<i>Branchiostychis americanus</i>	38, <u>39</u>
<i>Bregmaceros atlanticus</i>	<u>81</u>
Bregmacerotidae	67, <u>81</u>
<i>Brevoortia patronus</i>	<u>71</u>
<i>Brotula barbata</i>	<u>112</u>
Brotulidae	67
<i>Bunodactis</i> sp.	<u>45</u>
<i>Busycon perversum</i>	<u>46</u>
<i>Calappa springeri</i>	<u>58</u>
Calappidae	<u>58</u>
<i>Calliactis polyopus</i>	<u>45</u>
<i>Callinectes sapidus</i>	43, 59, <u>60</u>
<i>Callinectes similis</i>	<u>38</u> , <u>39</u> , 43, <u>59</u> , 62, <u>130</u> , <u>138</u>
Carangidae	36, 67, <u>88</u>
<i>Caranx crysos</i>	31, <u>36</u> , <u>88</u>
Carcharhinidae	67, <u>68</u>
<i>Carcharhinus falciformes</i>	69
<i>Carcharhinus limbatus</i>	69
<i>Caulolatilus cyanops</i>	<u>87</u>
<i>Centropristes ocyurus</i>	39, <u>40</u> , <u>83</u> , <u>85</u> , <u>130</u> , <u>138</u>
<i>Centropristes philadelphicus</i>	<u>84</u>
<i>Chaetodipterus faber</i>	<u>105</u>

<i>Chasmocarcinus mississippiensis</i>	64
<i>Chilomycterus schoepfi</i>	127
<i>Chloroscombrus chrysurus</i>	88, 130
<i>Citharichthys macrops</i>	117
<i>Citharichthys spilopterus</i>	39, 40, 117, 138
Clupeidae	28, 35, 67, 71
<i>Clymenella torquata</i>	38, 39
<i>Clypeaster</i> sp.	66
Clypeasteridae	66
Congridae	67
<i>Congrina flava</i>	79
<i>Cyclopsetta chittendeni</i>	118, 130
Cynoglossidae	67, 124
<i>Cynoscion arenarius</i>	90, 92, 130, 133, 139
<i>Cynoscion nothus</i>	91
<i>Cynoscion</i> sp.	30, 36
Dasyatidae	67, 70
<i>Dasyatis americana</i>	70
<i>Dasyatis say</i>	71
<i>Dibranchius atlanticus</i>	128, 130
Diodontidae	67, 127
<i>Diopatra cuprea</i>	38, 39
<i>Diplectrum arcuarium</i>	84, 130
<i>Doliolum</i> sp.	28, 29, 30, 31, 34
<i>Doryteuthis plei</i>	46
<i>Dromidia antillensis</i>	58
<i>Dromidia</i> sp.	58
Dromiidae	58
Echeneidae	67, 125
<i>Echeneis naucrates</i>	125
<i>Echinaster modestus</i>	65
Echinasteridae	65
Engraulidae	35, 43, 67, 73
<i>Engyophrys sentus</i>	120
Ephippidae	67, 105
<i>Equetus acuminatus</i>	93
<i>Etropus crossotus</i>	39, 40, 120, 130, 138
<i>Etrumeus sadina</i>	72
<i>Eucinostomus argenteus</i>	89
Exocoetidae	43
Gadidae	43, 67, 82
<i>Galeichthys felis</i>	78, 80, 130
Gerridae	67, 89
Gobiidae	67, 108
Goneplacidae	64
<i>Gymnachirus melas</i>	122
<i>Gymnachirus texae</i>	122
<i>Gymnothorax nigromarginatus</i>	79
<i>Halieutichthys aculeatus</i>	128
<i>Harengula pensacola</i>	72, 130
<i>Hepatus epheliticus</i>	59
<i>Hippocampus erectus</i>	83
<i>Hippocampus zosterae</i>	83
<i>Hoplunnis macrurus</i>	79
Hormathiidae	45
<i>Kathetostoma albigutta</i>	111
<i>Lactophrys quadricornis</i>	126
<i>Lagocephalus laevigatus</i>	126
<i>Lagodon rhomboides</i>	30, 36, 100, 101, 130
<i>Larimus fasciatus</i>	93

<i>Leiostomus xanthurus</i>	94, 95, 130, 133, 139
<i>Lepophidium graellsii</i>	<u>112</u> , 130
Leucosiidae	58
<i>Libinia emarginata</i>	64
<i>Liriope tetraphyla</i>	27, 28
Loliginidae	46
<i>Lolligo pealei</i>	47, 130
<i>Lolliguncula brevis</i>	<u>46</u> , 48, 130
Lophiidae	67, 128
<i>Lophiomus</i> sp.	<u>128</u>
<i>Lucifer faxoni</i>	28, 29, 30, 31, <u>32</u> , 43
<i>Luidia clathrata</i>	<u>65</u> , 130
Luidiidae	65
Lutjanidae	67, 86
<i>Lutjanus campechanus</i>	86
Macrouridae	67
Majidae	64
<i>Manta birostris</i>	71
Melongenidae	46
<i>Menidia beryllina</i>	43
<i>Menticirrhus americanus</i>	94
<i>Micropogon undulatus</i>	36, 97, 98, 130, 132, <u>139</u>
<i>Molpadia cubana</i>	66
Molpadiidae	66
<i>Monacanthus hispidus</i>	<u>126</u>
<i>Mugil cephalus</i>	43, <u>116</u>
Mugilidae	43, 67, <u>116</u>
Millidae	43, 67
<i>Mullus auratus</i>	43, 99
Muraenidae	67, 79
<i>Mustelus canis</i>	<u>68</u>
<i>Narcine brasiliensis</i>	70
<i>Negaprion brevirostris</i>	69
<i>Neomerinthe pollux</i>	<u>108</u>
Octopodidae	47
<i>Octopus vulgaris</i>	<u>47</u>
Ogcocephalidae	67, 128
<i>Ogcocephalus parvus</i>	<u>129</u>
<i>Ogcocephalus</i> sp.	<u>129</u>
<i>Oikopleura</i>	<u>34</u>
<i>Oikopleura</i> sp.	28, 29
Ophichthidae	67, 81
<i>Ophichthus ocellatus</i>	<u>81</u>
Ophidiidae	67, 112
<i>Ophidion welschi</i>	<u>112</u>
Ophiuroidae	29, <u>34</u>
<i>Opiathonema oglinum</i>	<u>73</u>
<i>Orthopristis chrysopterus</i>	<u>90</u>
Ostraciidae	67, 126
<i>Ovalipes ocellatus</i>	<u>63</u> , 43
Paguridae	28, 57
<i>Pagrus sedecium</i>	<u>103</u>
<i>Pagrus</i> sp.	39, 40
<i>Pagurus floridanus</i>	57
<i>Paralichthys albigutta</i>	<u>120</u>
<i>Paralichthys lethostigma</i>	<u>121</u>
<i>Paralichthys squamilentus</i>	<u>121</u>
<i>Pecten papyraceus</i>	38, 39, <u>46</u>
Pectinidae	46
Penaeidae	50

<i>Penaeus aztecus</i>	50, 52, 130, 133, 138, 139
<i>Penaus duorarum</i>	51, 130
<i>Penaeus fluviatilis</i>	51, 53, 55, 130
<i>Penilla uirostris</i>	28, 29, 31, 33
<i>Peprilus alepidotus</i>	112
<i>Peprilus burti</i>	43, 113, 114, 130, 133, 139
<i>Peprilus paru</i>	113
<i>Peristedion gracile</i>	109
<i>Persephona crinitia</i>	58
<i>Petrochirus bahamensis</i>	57
<i>Physalia physalis</i>	45
<i>Physiculus fulvus</i>	82
<i>Pogonias cromis</i>	99
<i>Polydactylus octonemus</i>	116
Polynemidae	67, 116
Pomadasyidae	67, 90
Pomatomidae	67, 87
<i>Pomatomus saltatrix</i>	87
<i>Pontinus longispinis</i>	108
<i>Porcellana sayana</i>	57
Porcellanidae	57, 28
<i>Porichthys porosissimus</i>	127
Portunidae	43, 59
<i>Portunus gibbesii</i>	38, 39, 43, 63
<i>Portunus sayi</i>	43, 63
<i>Portunus spinicarpus</i>	64
<i>Portunus</i> sp.	39, 40
Priacanthidae	67, 87
<i>Priacanthus arenatus</i>	87
<i>Prionotus alatus</i>	109
<i>Prionotus ophryas</i>	109
<i>Prionotus paralatus</i>	109
<i>Prionotus pectoralis</i>	109
<i>Prionotus roseus</i>	110
<i>Prionotus rubio</i>	110, 130
<i>Prionotus scitulus</i>	110
<i>Prionotus stearnsi</i>	110
<i>Prionotus tribulus</i>	111
<i>Pristipomoides andersoni</i>	87
Rachycentridae	67, 88
<i>Rachycentron canadum</i>	71, 88
<i>Raja eglanteria</i>	70
<i>Raja texana</i>	70
Rajidae	67, 70
Raninidae	57
<i>Raninoides louisianensis</i>	57
<i>Raninoides</i> sp.	58
<i>Renilla mulleri</i>	38, 39, 45, 130, 138
Renillidae	45
Rhinobatidae	67, 69
<i>Rhinobatos lentiginosus</i>	69
<i>Rossia tenera</i>	47
<i>Sagitta</i> sp.	28, 29, 30, 31, 34
<i>Saurida brasiliensis</i>	76
Sciaenidae	36, 67, 90
<i>Scoriodon terraenovae</i>	68
<i>Scomber colias</i>	107
<i>Scomberomorus maculatus</i>	107
Scombridae	67, 107
<i>Scorpaena calcarata</i>	108
Scorpaenidae	67, 108
<i>Scyllaea pelagica</i>	46
Scyllaeidae	46
Scyllaridae	56

<i>Scyllarides nodifer</i>	56
<i>Scyllarus</i> sp.	56
<i>Selar crumenophthalmus</i>	89
Sepiolidae	47
Sergestidae	32, 43
Serranidae	67, 83
<i>Serranus atrobranchus</i>	84, 130
<i>Serranus notospilus</i>	84
<i>Sicyonia brevirostris</i>	39, 40, 54, 130
<i>Sicyonia dorsalis</i>	54, 130
Soleidae	67, 122
<i>Solenocera vioscai</i>	54
<i>Solenocera</i> sp.	56
Sparidae	36, 67, 100
<i>Sphaeroides nephelus</i>	126
<i>Sphaeroides parvus</i>	43
<i>Sphyræna quachancho</i>	115
Sphyrænidae	67, 115
<i>Sphyrna tiburo</i>	68
<i>Sphyrna zygaena</i>	69
Sphyrnidae	67, 68
<i>Squatina dumerili</i>	69
Squatinae	67, 69
<i>Squilla chydæa</i>	38, 39, 49
<i>Squilla empusa</i>	38, 39, 49, 130, 138
Squillidae	49
<i>Steindachneria argentea</i>	82
<i>Stenocionops spinimana</i>	64
<i>Stenorynchus seticornis</i>	65
<i>Stenotomus caprinus</i>	103, 104, 130, 132, 139
Stromateidae	43, 67, 112
<i>Syacium gunteri</i>	121, 123, 130
<i>Syacium papillosum</i>	122
<i>Symphurus diomedianus</i>	124
<i>Symphurus plagiata</i>	124
Syngnathidae	43, 67, 83
<i>Sygnathus floridae</i>	43
<i>Sygnathus scovelli</i>	43
Synodontidae	35, 67, 76
<i>Synodus foetens</i>	77, 130
Tetraodontidae	43, 67, 126
Torpedinidae	67, 70
<i>Trachinocephalus myops</i>	77
<i>Trachurus lathamii</i>	89, 130
<i>Trachypeneus similis</i>	56, 130
Trichiuridae	67, 106
<i>Trichiurus lepturus</i>	106
<i>Trichopsetta ventralis</i>	122
Triglidae	30, 31, 37, 67, 109
Umaridae	44
Uranoscopidae	67, 111
<i>Uranoscopus</i> sp.	111
<i>Urophycis floridanus</i>	82
<i>Urophycis regius</i>	43, 82
<i>Vomer setapinnis</i>	89, 130
Zeidae	67, 83
<i>Zenopsis ocellata</i>	83